



Jan

25 Cents

# Radio-Craft

for the  
Professional-Serviceman-Radiotrician

HUGO GERNSBACK Editor

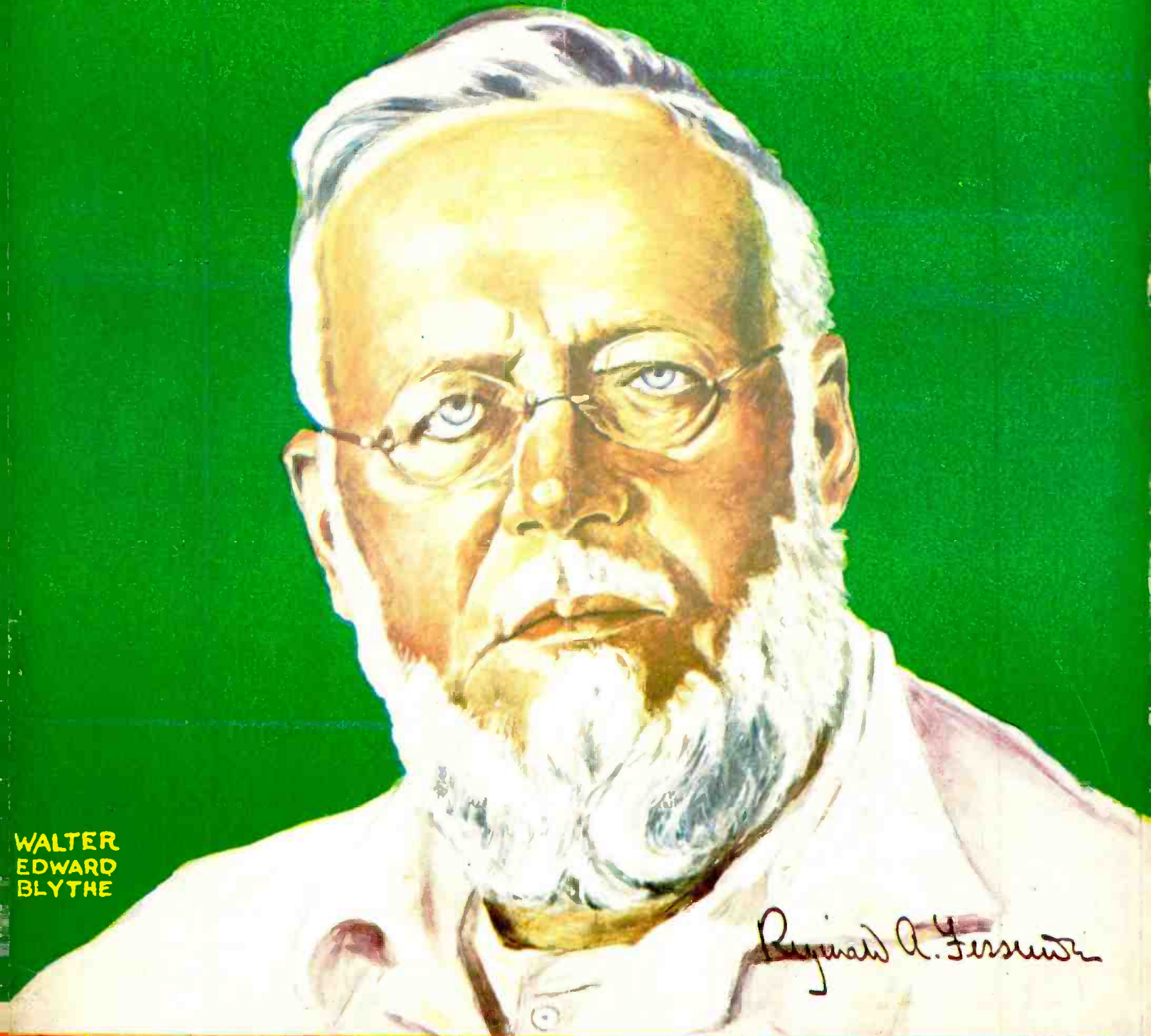

WALTER  
EDWARD  
BLYTHE

*Reginald A. Fessenden*

**Men who have made Radio:** *Reginald A. Fessenden*

# Thousands of Positions Open Right Now

at  
Salaries Ranging

## UP to \$200<sup>00</sup> per WEEK

for MOTION PICTURE SOUND Engineers

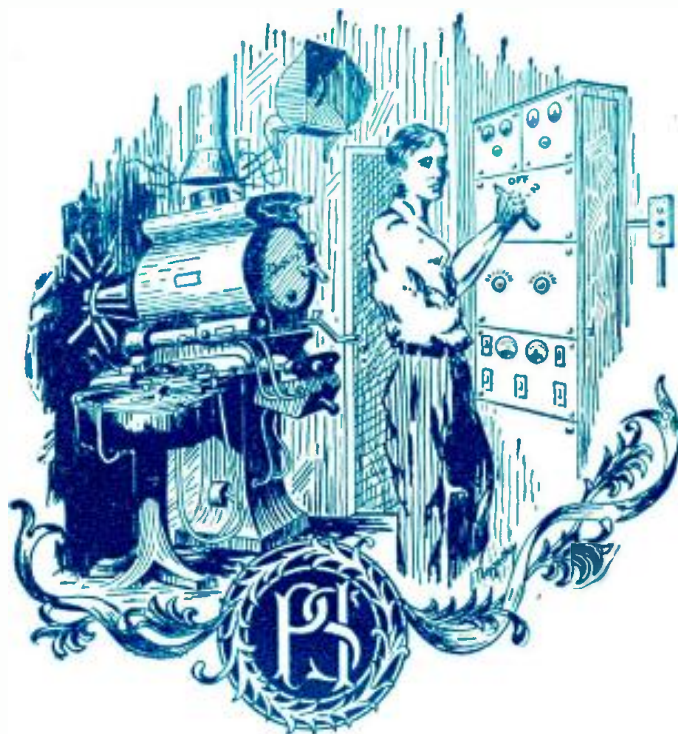

WE are in contact with chain theatres and manufacturers of Sound equipment who desire the services of competent sound men as engineers, projectionists, installation and service men. Our employment department will assist you in making a profitable connection free of charge.

### GUARANTEE

Our guarantee insures you that if you enroll as one of our students and take advantage of the many opportunities that your membership entitles you to your increased income will pay the tuition of the course many times. We unconditionally guarantee that if for any reason you are dissatisfied (you being the judge) we will refund every cent you have paid.

*Due to the fact that radio and sound are so closely allied, men with radio experience are the most adaptable.*

### POLICY

Our course on Sound Projection which is prepared by the most eminent authorities on Electrical Acoustics will qualify you for a Profession whose place in the engineering world is second to none. All of the available knowledge of the art and the underlying fundamental principles of sound is given to you in an everyday, plain-talk language, as well as two weeks' practical training in the operation, servicing and installation of Sound Equipment.

### DEMAND

In the 20,000 theatres throughout the United States and Canada,

which now employ approximately 50,000 projectionists, it is estimated that a very small per cent of this number are qualified to fill the position as Sound operators. Many thousands of new men will have to be taken into this field as fast as the many thousand unwired theatres are wired for sound as the additions of sound doubles the number of operators required. This condition will create many thousands of positions at salaries up to \$200.00 per week.

The tuition for these courses is very reasonable and is payable in easy installments as you study. Also you have the added convenience of studying at home in your spare time. Fill out and mail the coupon below today for special scholarship proposition.

Mail Coupon for Free Information

## PROJECTIONIST SOUND INSTITUTE

F. A. JEWELL, Gen. Mgr.

P. O. Box No. 28, Easton, Pa.

PROJECTIONIST SOUND INSTITUTE,  
P. O. Box No. 28, Easton, Pa.

RC-1

Gentlemen:

Please send me, by return mail, full details of your Special Scholarship Proposition on Sound Projection.

Name.....

Address.....

City..... State.....



# 148 PAGES of outstanding RADIO VALUES

On every page of this big catalog for 1930 you will find radio merchandise of unusual interest—priced at the lowest wholesale quotations. No radio enthusiast or dealer can afford to be without it.

The latest radio devices and improvements are illustrated—sets, accessories, parts and kits—at price-saving reductions that spell the buyer's opportunity. Astounding offerings in new, humless, Screen Grid A. C. all-electric and battery operated sets; beautiful and artistic consoles; dynamic speakers of great volume and rich tone; and everything considered standard in accessories, parts and kits.

The startling values listed in this Catalog are made possible by our tremendous buying power, low cost of operation and willingness to take a conservative profit. Quick service, expert cooperation and unusual satisfaction are assured to every customer.

Don't fail to get this **FREE** wonder book. It will save you big money. Mail the Coupon Today!

**New!**  
SCREEN GRID MODELS

**FREE!**  
CATALOG  
COUPON!

Chicago Salvage Stock Store  
Dept. 130  
509 So. State St., Chicago, Ill.

Kindly send me (free of charge and postpaid) your new 148-page Book of Radio Bargains.

Name.....  
Address.....  
City..... State.....

**CHICAGO SALVAGE STOCK STORE**  
**WORLD'S LARGEST RADIO STORE**  
509 So. State St. Dept. 130 Chicago, Ill..

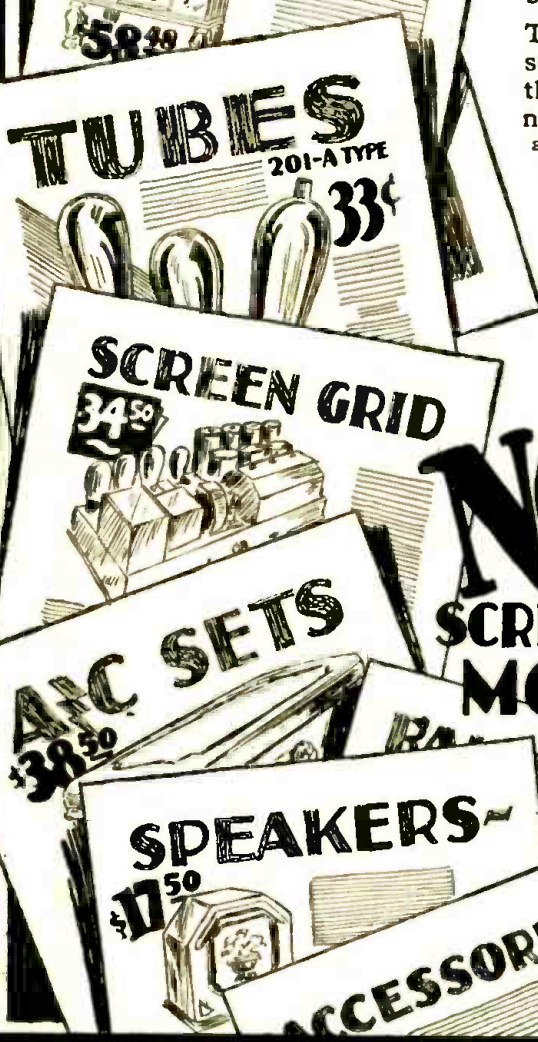



## The Man with the "Grasshopper Mind"

**Y**OU know this man as well as you know YOURSELF. His mind nibbles at EVERYTHING and masters NOTHING.

At home in the evening he tunes in the radio—gets tired of it—then glances through a MAGAZINE—can't get interested. Finally, unable to CONCENTRATE on anything, he either goes to the MOVIES or FALLS ASLEEP in his chair.

At the OFFICE he always takes up the EASIEST thing first, puts it down when it gets HARD, and starts something else. JUMPS from ONE THING TO ANOTHER all the time!

There are thousands of these PEOPLE WITH GRASSHOPPER MINDS in the world. In fact they are the very people who do the world's MOST TIRESOME TASKS—and get but a PITTANCE for their work.

They do the world's CLERICAL WORK, and routine drudgery. Day after day, week after week, month after month, year after year—ENDLESSLY—they HANG ON to the jobs that are smallest-salaried, longest-houred, least interesting, and poorest-future!

If YOU have a "grasshopper mind" you know that this is TRUE. And you know WHY it is true. Even the BLAZING SUN can't burn a hole in a little piece of TISSUE PAPER unless its rays are focussed and concentrated ON ONE SPOT!

A BRAIN THAT BALKS at sticking to ONE THING FOR MORE THAN A FEW MINUTES surely cannot be depended upon to get you anywhere in your YEARS of life!

The TRAGEDY of it all is this: you know that RIGHT NOW you are merely jumping HERE AND THERE. Yet you also know that you have WITHIN YOU the intelligence, the earnestness, and the ability that can take you right to the high place you want to reach in life!

What is WRONG? WHAT'S holding you back?

Just one fact—one SCIENTIFIC fact. That is all. And when you know what it IS, then you can easily learn how to apply it; make it carry you STEADILY, POSITIVELY, AND DIRECTLY to prosperity and independence.

That fact is one which has been PROVEN and stated by the world's foremost scientists and psychologists. You are only ONE-TENTH as successful as you COULD be! Why? BECAUSE, as Science says, you are using only ONE-TENTH of your real BRAIN-POWER!

TEN per cent of his brain is all the AVERAGE person uses. He is paid for ONE-TENTH of what he really possesses because that is all he actually USES. The remainder lies dormant. The longer it is unused, the harder it becomes to use it. For the mind is like a muscle. It grows in power through exercise and use. It weakens and deteriorates with idleness.

What can you DO about it? That is the question you are asking yourself. Here is a suggestion.

Spend 2c for a postage stamp. Send in the coupon below for a copy of "Scientific Mind Training." There is no further obligation whatever. You need not spend another penny.

This little book will tell you the secret of self-confidence, of a strong will, of a powerful memory, of unflagging concentration. It tells you how to acquire directive powers, how to train your imagination (the greatest force in the world), how to make quick, accurate decisions, how to reason logically—in short, how to make

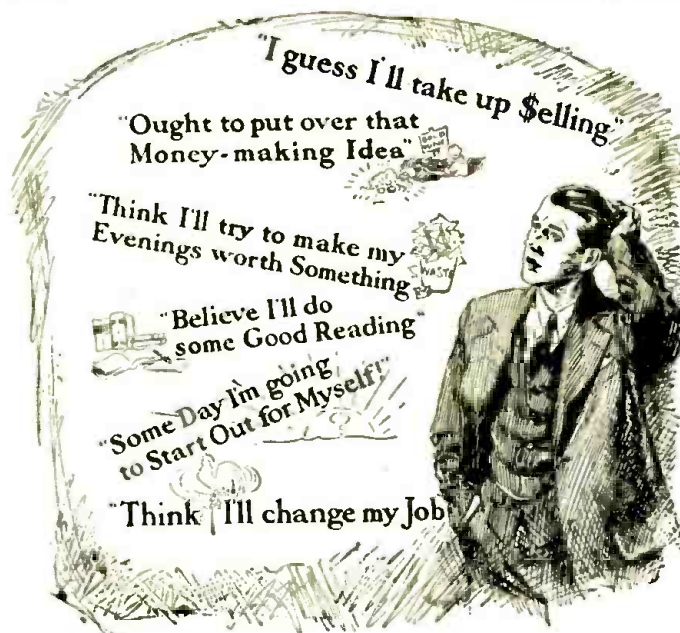

your brain an instrument of all-around POWER. It tells you how to banish the negative qualities like forgetfulness, brain fag, inertia, indecision, self-consciousness, lack of ideas, mind wandering, lack of system, procrastination, timidity.

Men like Judge Ben B. Lindsey, Sir Harry Lauder, Prince Charles of Sweden, Jerome K. Jerome, the famous novelist; Frank P. Walsh, Chairman of the National War Labor Board, and hundreds of others equally famous, praise the simple method of increasing brain power and thought power described in this free book. OVER 700,000 OTHERS PRAISE IT.

You have only TWO CENTS to lose by writing for your copy. You may GAIN thousands of dollars, peace of mind, happiness, independence!

Thousands who read this announcement will DO NOTHING about it. The effort and the will needed to send for this book—which is FREE—may be lacking. How can these people EVER gain what they hope for, crave for? They are the skeptics, the doubters, the "show me" wiseacres.

Other thousands will say, "I can lose only TWO CENTS. I may GAIN a great deal by reading 'Scientific Mind Training.' I will send for it NOW. It promises too much for me to RISK MISSING."

The thousands who are open minded—who are willing to learn something to their advantage—will ACT on their impulse to send the coupon. They will be better, stronger minded for having TAKEN SOME ACTION about their lives, even if they do nothing more than to READ a booklet about the inner workings of the mind. For your own sake—and for the sake of your loved ones, don't continue to GAMBLE that your future will be bright whether or not you DO anything about it! Mail the coupon today—NOW.

THE PELMAN INSTITUTE OF AMERICA  
Suite 2291, 71 West 45th Street, New York City  
Offices in London, Paris, Stockholm, Delhi,  
Durban and Melbourne

The Pelman Institute of America  
Suite 2291, 71 West 45th Street  
New York City

Please send me without obligation your free booklet, "Scientific Mind Training." This does not place me under any obligation and no salesman is to call on me.

Name \_\_\_\_\_  
Address \_\_\_\_\_  
City \_\_\_\_\_ State \_\_\_\_\_

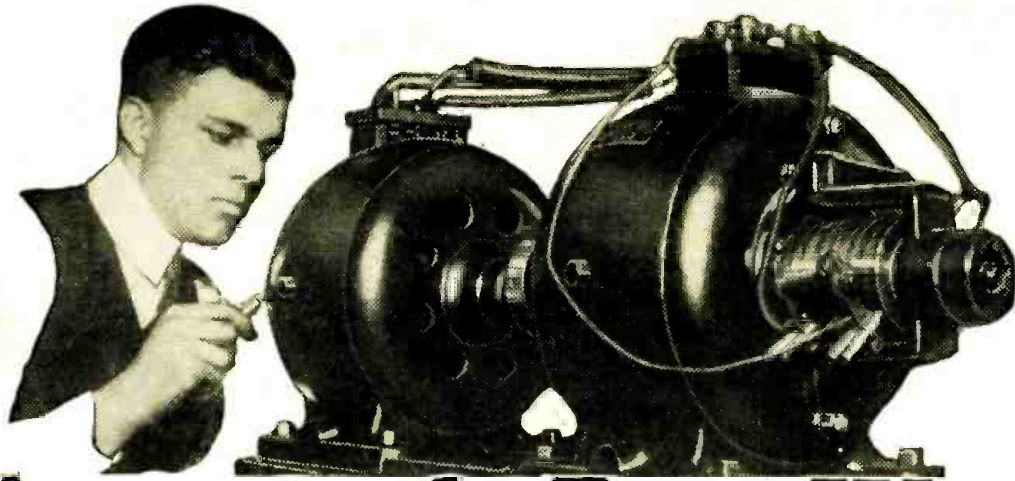

# Amazingly Easy Way to get into ELECTRICITY

Don't spend your life waiting for \$5 raises in a dull, hopeless job. Now . . . and forever . . . say good-bye to 25 and 35 dollars a week. Let me show you how to qualify for jobs leading to salaries of \$50, \$60 and up, a week, in Electricity —NOT by correspondence, but by an amazing way to teach, RIGHT HERE IN THE GREAT COYNE SHOPS. You become a practical expert in 90 days! Getting into Electricity is far easier than you imagine!

## Learn Without Lessons in 90 DAYS By Actual Work — in the Great Shops of Coyne

Lack of experience—age, or advanced education bars no one. I don't care if you don't know an armature from an air brake—I don't expect you to! I don't care if you're 16 years old or 48—it makes no difference! Don't let lack of money stop you. Most of the men at Coyne have no more money than you have.

### Railroad Fare Allowed

I will allow your railroad fare to Chicago, and if you should need part-time work I'll assist you to it. Then, in 12 brief weeks, in the great roaring shops of Coyne, I train you as you never dreamed you could be trained on a gigantic outlay of electrical apparatus . . . costing hundreds of thousands of dollars . . . real dynamos, engines, power plants, autos, switchboards, transmitting stations . . . everything from doorbells to farm power and lighting . . . full-sized . . . in full operation every day!

### No Books—No Printed Lessons

No books, no baffling charts . . . all real actual work . . . right here in the great Coyne school . . . building

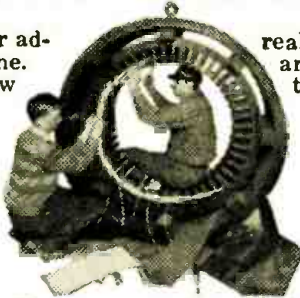

### Prepare for Jobs Like These

Here are a few of hundreds of positions open to Coyne-trained men. Our free employment bureau gives you lifetime employment service.

- Armature Expert, to \$100 a Wk.
- Substation Operator \$60 a Week and up
- Auto Electrician \$110 a Week
- Inventor . . . . . Unlimited
- Maintenance Engineer up to \$150 a Week
- Service Station Owner up to \$200 a Week
- Radio Expert up to \$100 a Week

real batteries . . . winding real armatures, operating real motors, dynamos and generators, wiring houses, etc., etc. That's a glimpse of how we make you a master practical electrician in 90 days, teaching you far more than the average ordinary electrician ever knows and fitting you to step into jobs leading to big pay immediately after graduation. Here, in this world-famous *Parent school*—and nowhere else in the world—can you get this training!

### Jobs—Pay—Future

Don't worry about a job, Coyne training settles the job question for life. Demand for Coyne men often exceeds the supply. Our

employment bureau gives you a lifetime service. Two weeks after graduation, Clyde F. Hart got a position as electrician for the Great Western Railroad at over \$100 a week. That's not unusual. We can point to Coyne men making up to \$600 a month. \$60 a week is only the beginning of your opportunity. You can go into radio, battery, or automotive electrical business for yourself and make up to \$15,000 a year.

### GET THE FACTS

Coyne is your one great chance to get into electricity. Every obstacle is removed. This school is 30 years old—Coyne training is tested—proven beyond all doubt—endorsed by many large electrical concerns. You can find out everything absolutely free. Simply mail the coupon and let me send you the big, free Coyne book of 150 photographs . . . facts . . . jobs . . . salaries . . . opportunities. Tells you how many earn expenses while training and how we assist our graduates in the field. This does not obligate you. So act at once. Just mail coupon.

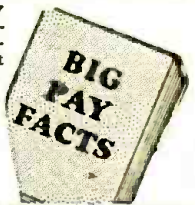

### Get This FREE Book

Mr. H. C. LEWIS, President  
COYNE ELECTRICAL SCHOOL, Dept. 10-95  
500 S. Paulina St., Chicago, Ill.

Dear Mr. Lewis:  
Without obligation send me your big free catalog and all details of Railroad Fare to Chicago. Free Employment Service, Radio, Aviation Electricity, and Automotive Courses, and how I can "earn while learning."

Name.....  
Address.....  
City..... State.....

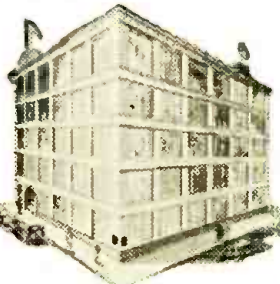

### Now in Our New Home

This is our new, fire-proof, modern home wherein is installed thousands of dollars' worth of the newest and most modern Electrical Equipment of all kinds. Every comfort and convenience has been arranged to make you happy and contented during your training.

# COYNE ELECTRICAL SCHOOL

H. C. LEWIS, Pres. Established 1899

500 S. Paulina Street • Dept. 10-95 • Chicago, Illinois

H. GERNSBACK, President  
S. GERNSBACK, Treasurer  
J. M. HERZBERG, Vice-President  
I. S. MANHEIMER, Secretary



VOLUME 1  
NUMBER 7

R. D. WASHBURNE,  
Technical Editor

HUGO GERNSBACK, Editor-in-Chief

C. P. MASON,  
Associate Editor

### Fooling the Public By HUGO GERNSBACK

THE clipping reproduced herewith was published in the columns of the *New York Sun*, under date of November 11. It gives a correct impression of the ideas entertained by the average man, who does not know anything about radio and who has had sad, but interesting, experiences with the average radio dealer.

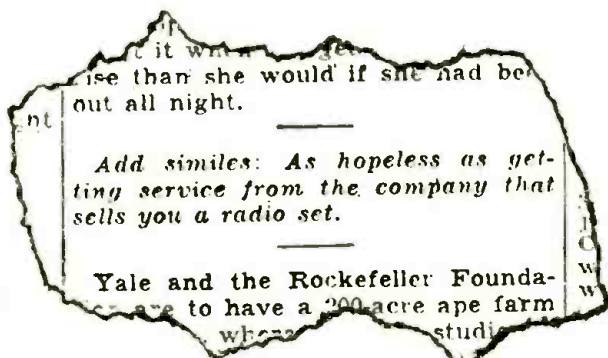

The trouble in this country today is that radio has not, as yet, been put on a business-like basis; such as prevails, for instance, in the automobile industry. It is an open secret that the last thing a set manufacturer expects to do is to service a set; because it is, seemingly, much easier at the present time to sell a man a new set than to put an old one into shape.

Such manufacturers will not openly say so; but the actions of many of even our large set manufacturers are such that we may well wonder if they are serious when they say that they are providing service for their own sets. When radio set manufacturers go as far openly as to discourage Service Men, and refuse to provide them with servicing instructions, we must come to the conclusion that there is something rotten in Radiodom.

Of course, the radio set manufacturer will say that he wants only his "own" Service Man to service his sets; but, in most localities, the same manufacturer has no Service Man, so how is he to take care of such sets?

The public will stand for the present abuses only so long. When a man who has a receiver of a certain make finds that he cannot have it serviced, nine times out of ten he will purchase one of another make when he can; because he does not feel that the manufacturer has kept faith with him.

What the radio trade today needs, and needs urgently, is a speedy recognition of the Service Man, and the duty to provide him with all information that he asks for. The present ostrich-like policy cannot go on forever; and it is about time for the radio set manufacturer to recognize that an intelligent Service Man is an asset to him, rather than a liability—as most set manufacturers foolishly think today.

### Contents of this Issue

	Page
PRESENTING MR. RIDER.....	295
LEAVES FROM SERVICE MEN'S NOTE BOOKS By RADIO-CRAFT Readers.....	295
THE SERVICE MAN'S OPEN FORUM.....	297
RADIO SERVICE DATA SHEETS.....	298
SERVICING THE FRESHMAN "N"—By Harold Weiler.....	300
OUTPUTS OF POWER TUBES.....	301
OPERATING NOTES FOR RADIO SERVICE MEN By Bertland M. Freed.....	302
PRESCRIPTIONS OF A RADIO DOCTOR—By Paul L. Welker.....	303
A COMPLETE PORTABLE RADIO TESTING LABORATORY By Geo. C. Miller.....	304
CAUSES AND CURE OF INTERFERENCE—By F. R. Bristow.....	307
MEN WHO MADE RADIO—Reginald A. Fessenden.....	309
NATIONAL LIST OF SERVICE MEN REPLY BLANK.....	309
THE SHORT-WAVE RECEIVER AS A MONEY MAKER By John Geloso.....	310
SIX-INCH RADIO WAVES—By Ernst Gerhard.....	312
SHORT-WAVE STATIONS AND THEIR SCHEDULES.....	313
A NOVEL SCANNING DISC FOR TELEVISION By Paul L. Clark.....	314
NEW RADIO DEVICES FOR SHOP AND HOME.....	315
TELEVISION IMAGES IN NATURAL COLORS By Herbert E. Ives.....	316
THE DEVELOPMENT OF THE MODERN SOUND REPRODUCER By O. C. Roos.....	318
USES OF A.C. AND D.C. SCREEN-GRID TUBES By J. A. Dowie.....	320
THE SEVEN-GRID VACUUM TUBE.....	321
VACUUM TUBES FOR RADIO RECEPTION—PART IV By C. W. Palmer.....	322
FROM MICROPHONE TO MODULATOR—By C. S. Gleason.....	324
MAKING LOW-LOSS COILS ON A CELLULOID BASE By C. W. Teek.....	326
RADIO-CRAFT KINKS.....	328
HOW TO MAKE A WAVE-RESONANCE TUNER By S. R. Winters.....	329
THE ELECTROSTATIC "RADIOPHON"—By Gustav Fiehhorn.....	330
THE RADIO CRAFTSMAN'S OWN PAGE—By Himself.....	331
INFORMATION BUREAU.....	332
BOOK REVIEW.....	351

### In Forthcoming Issues

Sound-Projection Engineering.....	Special Articles
Testing Radio Receivers.....	C. Washburn, Jr.
Servicing the A.K. 37.....	Harold Weiler
Amplifying the Output of a Condenser Microphone.....	J. E. Smith

RADIO-CRAFT is published monthly, on the fifth of the month preceding that of date; its subscription price is \$2.50 per year. (In Canada and foreign countries, \$3.00 a year to cover additional postage.) Entered at the postoffice at Mt. Morris, Ill., as second-class matter under the act of March 3, 1879. Title registered U. S. Patent Office. Trademarks and copyrights by permission of Gernsback Publications, Inc., 98 Park Place, New York City. Copyright 1929 by G. P., Inc. Text and illustrations of this magazine are copyright and must not be reproduced without permission of the copyright owners. We are also agents for SCIENCE WONDER STORIES, ALL WONDER STORIES and SCIENCE WONDER QUARTERLY. Subscriptions to these magazines may be taken in combination with RADIO-CRAFT at reduced club rates. Write for information.

Published by

## TECHNI-CRAFT PUBLISHING CORPORATION

Publication Office: 404 No. Wesley Ave., Mount Morris, Illinois

Editorial and Advertising Offices  
96-98 Park Place, New York City

Western Advertising Office  
737 North Michigan Avenue, Chicago, Ill.

L. F. McCLURE, Western Advertising Representative

January, 1930

# of the 40 Easy Ways to Make \$3<sup>00</sup> an Hour

## In Your Spare Time

# in RADIO

**Below**

are a few of  
the reports  
from those now  
cashing in on the  
"40 Easy Ways"

**T**HE four plans shown are but a sample of the many ways in which our members are making \$3.00 an hour upwards, spare time and full time, from the day they join the Association. If you want to get into Radio, have a business of your own, make \$50 to \$75 weekly in your spare time, investigate the opportunities offered the inexperienced, ambitious man by the Association.

### Our Members Earning Thousands of Dollars Every Week

The Association assists men to cash in on Radio. It makes past experience unnecessary. As a member of the Association you are trained in a quick, easy, practical way to install, service, repair, build and rebuild sets—given sure-fire money-making plans developed by us—helped to secure a position by our Employment Department. You earn while you learn, while you prepare yourself for a big-pay Radio position.

The Association will enable you to buy parts at wholesale, start in business without capital, help you get your share of the \$600,000,000 spent annually for Radio. As a result of the Association, men all over the country are opening stores, increasing their pay, passing licensed operator examinations, landing big-pay positions with Radio makers.



### Mail Coupon Today for the FREE HANDBOOK

It is not only chock-full of absorbing information about Radio, but it shows you how easily you can increase your income in your spare time. Mailing the coupon can mean \$50 to \$75 a week more for you.

**Radio Training Association of America**  
4513 Ravenswood Avenue Dept. RCA-1 Chicago, Illinois



**Clears \$3,000.00** Frank J. Deutch, Pa.—"Since joining the Association I have cleared nearly \$3,000.00. It is almost impossible for a young fellow to fail, no matter how little education he has, if he will follow your easy ways of making money."

**\$1,100.00 in 6 Weeks** J. R. Allen, Calif.—"Have done over \$1,100.00 worth of business in the last 6 weeks. Next month I am going to open up a store of my own. I never knew that money could come so fast and easy."

**\$25.00 a Week Spare Time** N. J. Friedrich, N. Y.—"I have averaged \$25.00 a week for the last 7 months even though I am not a graduate but just learning."

**Training Lands Him Job** R. C. Kirk, N. C.—"Your training has been very valuable to me. I landed a job with the big department store out here a few weeks ago because I had my membership card with me. There were a large bunch of applications ahead of me."

## ACT NOW If You Wish NO-COST Membership

For a limited time we will give to the ambitious man a No-Cost Membership which need not—should not—cost you a cent. For the sake of making more money now, and having a better position in the future, mail coupon below now. You'll always be glad you did.

Radio Training Association of America  
Dept. RCA-1 4513 Ravenswood Ave., Chicago, Ill.

Gentlemen: Please send me by return mail full details of your Special No-Cost Membership Plan, and also a copy of your Radio Handbook.

Name

Address

City

State

**R. T. I.** QUALIFIES YOU TO MAKE MONEY AND ITS SERVICE KEEPS YOU UP-TO-DATE WITH THE NEWEST DEVELOPMENTS IN RADIO, TELEVISION, AND TALKING PICTURES.

January, 1930

Easy to Get into  
this **BIG**  
Money Making  
Work

\$60 to \$125<sup>00</sup>  
**A WEEK**  
Radio  
Operator

\$8 to \$15<sup>00</sup>  
**A DAY**  
Servicing and  
Repairing Radio Sets

\$5000<sup>00</sup> **A YEAR**  
AND UP  
Radio Engineer  
for Broadcasting Station

\$85<sup>00</sup> **A WEEK**  
Installing and  
Repairing Talking  
Picture Equipment

**GOOD JOBS** Right at Your Finger Tips  
WHEN YOU ARE R.T.I. TRAINED IN  
**RADIO-TELEVISION-Talking Pictures**

**BIG PAY JOBS! SPARE TIME PROFITS! A FINE BUSINESS OF YOUR OWN!** They're all open to you and other live wire men who answer the call of RADIO. The fastest growing industry in the world needs more trained men. And now come Television and Talking Movies—the magic sisters of Radio. Will you answer this call? Will you get ready for a big pay job Now and step into a BIGGER ONE later on? You can do it EASILY now.

**R. T. I. Home Training Puts You In This Big Money Field**

Radio alone, pays over 200 MILLION DOLLARS a year in wages in Broadcasting, Manufacturing, Sales, Service, Commercial Stations and on board the big sea going ships, and many more men are needed. Television and Talking Movies open up other vast fields of money-making opportunities for ambitious men. Get into this great business that is live, new and up-to-date, where thousands of trained men easily earn \$60 to \$100 a week—where \$10,000 a year jobs are plentiful for men with training plus experience.

**Easy To Learn At Home—In Spare Time** Learning Radio the R. T. I. way with F. H. Schnell, the "Ace of Radio" behind you is EASY, INTERESTING, really FUN. Only a few spare hours are needed and lack of education or experience won't bother you a bit. We furnish all necessary testing and working apparatus and start you off on practical work you'll enjoy—you learn to do the jobs that pay real money and which are going begging now for want of competent men to fill them.

**Amazingly Quick Results**

You want to earn BIG MONEY, and you want some of it QUICK. R. T. I. "Three in One" Home Training—Radio-Television-Talking Movies—will give it to you, because it's easy, practical, and



**FRED H. SCHNELL**  
Chief of R. T. I. Staff  
Twenty years of Radio Experience. First to establish two-way amateur communication with Europe. Former Traffic Manager of American Radio Relay League. Lieut. Commander U.S.N.R. Inventor and Designer Radio Apparatus. Consultant Radio Engineer. Now in charge of R. T. I. Radio Training—and you will like his friendly manner of helping you realize your ambition.

is kept right up-to-date with last minute information. In a few weeks you can be doing actual Radio work, making enough EXTRA MONEY to more than pay for your training. In a few short months you can be all through—ready to step into a good paying job or start a business of your own. A BIG JOB—BIG MONEY—A BIG FUTURE. There is no other business in the world like it.

**Investigate—Send For R. T. I. Book Now**

Don't waste a minute. Find out what the great Radio Industry, which has grown faster than the Automobile and Motion Picture business, has to offer you. Find out what other men are earning. SEE HOW EASILY YOU CAN GET STARTED. Get the facts about Radio, Television and the Talking Pictures, first hand, in the big R. T. I. FREE BOOK. Learn what this R. T. I. "Three in One" Home Training can do for you. Mail the Coupon for FREE BOOK NOW.

**Radio & Television Institute**  
Dept. 771  
4806 St. Anthony Court, Chicago



**R.T.I. Training Brings Big Jobs Like These!**



**Earned \$500 Extra Money in Two Months**

Your radio course has enabled me to earn over \$500 in two months' spare time work. Understand that this is all spare time work, as I have a permanent position with my father in our store. I give you all the credit for the above and as I said before, I wish to finish the entire course as soon as I can.—Your student, J. NOFFSINGER, Greenville, Ky. R. T. I. Box 37.



**Salary Raised 33 1-3% Since Enrolling**  
You may be interested to know that I am now Radio Service Manager for the H. N. Knight Supply Co. who are distributors for Eveready Radio Receivers in the State of Oklahoma, and Texas Panhandle, with an increase in salary of about 33 1-3% since I enrolled with your school.

Thanking you for your interest you have shown to me, and your wonderful course, I am, EARL E. GORDON, 618 East 8th St., Oklahoma City, Okla.



**Makes \$25 a Day**

Haven't forgotten you. How could I when I make as high as \$25.00 per day and have made \$600.00 in two months from Radio work. That's not so bad when I'm only 19 and in a small town. I just looked over the catalog you sent me before I enrolled, and you did about all you said you would and about as much more.—FLOYD KINSLEY, R. F. D. 2, Box 91, St. Joe, Ind.

**RADIO & TELEVISION INSTITUTE**  
Dept. 771 4806 St. Anthony Court, Chicago

Send me Free and prepaid your BIG BOOK "Tune In On Big Pay" and full details of your three-in-one Home Training (without obligating me in any way).

Name.....

Address.....

City..... State.....

**R. T. I.** TRAINS YOU AT HOME FOR A GOOD JOB OR A PROFITABLE PART TIME OR FULL TIME BUSINESS OF YOUR OWN



# 4 of the 40 Easy Ways to Make \$3.00 an Hour

## In Your Spare Time in RADIO

Below  
are a few of  
the reports  
from those now  
cashing in on the  
"40 Easy Ways"

THE four plans shown are but a sample of the many ways in which our members are making \$3.00 an hour upwards, spare time and full time, from the day they join the Association. If you want to get into Radio, have a business of your own, make \$50 to \$75 weekly in your spare time, investigate the opportunities offered the inexperienced, ambitious man by the Association.

### Our Members Earning Thousands of Dollars Every Week

The Association assists men to cash in on Radio. It makes past experience unnecessary. As a member of the Association you are trained in a quick, easy, practical way to install, service, repair, build and rebuild sets—given sure-fire money-making plans developed by us—helped to secure a position by our Employment Department. You earn while you learn, while you prepare yourself for a big-pay Radio position.

The Association will enable you to buy parts at wholesale, start in business without capital, help you get your share of the \$600,000,000 spent annually for Radio. As a result of the Association, men all over the country are opening stores, increasing their pay, passing licensed operator examinations, landing big-pay positions with Radio makers.

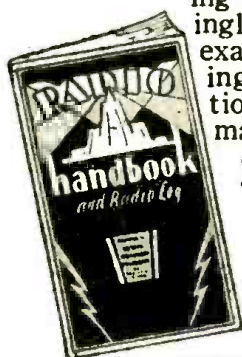

### Mail Coupon Today for the FREE HANDBOOK

It is not only chock-full of absorbing information about Radio, but it shows you how easily you can increase your income in your spare time. Mailing the coupon can mean \$50 to \$75 a week more for you.

**Radio Training Association of America**  
4513 Ravenswood Avenue Dept. RCA-1 Chicago, Illinois



**Clears \$3,000.00** Frank J. Deutch, Pa.—“Since joining the Association I have cleared nearly \$3,000.00. It is almost impossible for a young fellow to fail, no matter how little education he has, if he will follow your easy ways of making money.”

**\$1,100.00 in 6 Weeks** J. R. Allen, Calif. — “Have done over \$1,100.00 worth of business in the last 6 weeks. Next month I am going to open up a store of my own. I never knew that money could come so fast and easy.”

**\$25.00 a Week Spare Time** N. J. Friedrich, N. Y.—“I have averaged \$25.00 a week for the last 7 months even though I am not a graduate but just learning.”

**Training Lands Him Job** R. C. Kirk, N. C.—“Your training has been very valuable to me. I landed a job with the big department store out here a few weeks ago because I had my membership card with me. There were a large bunch of applications ahead of me.”

## ACT NOW If You Wish NO-COST Membership

For a limited time we will give to the ambitious man a No-Cost Membership which need not—should not—cost you a cent. For the sake of making more money now, and having a better position in the future, mail coupon below now. You'll always be glad you did.

Radio Training Association of America  
Dept. RCA-1 4513 Ravenswood Ave., Chicago, Ill.

Gentlemen: Please send me by return mail full details of your Special No-Cost Membership Plan, and also a copy of your Radio Handbook.

Name .....

Address .....

City ..... State .....

**R. T. I.** QUALIFIES YOU TO MAKE MONEY AND ITS SERVICE KEEPS YOU UP-TO-THE-MINUTE ON THE NEWEST DEVELOPMENTS IN RADIO, TELEVISION, AND TALKING PICTURES **R. T. I.**

Easy to Get into  
this **BIG**  
Money Making  
Work

\$60 to \$125<sup>00</sup>  
A WEEK  
Radio  
Operator

\$8 to \$15<sup>00</sup>  
A DAY  
Servicing and  
Repairing Radio Sets

\$5000<sup>00</sup> A YEAR  
AND UP  
Radio Engineer  
for Broadcasting Station

\$85<sup>00</sup> A WEEK  
Installing and  
Repairing Talking  
Picture Equipment

# GOOD JOBS Right at Your Finger Tips

WHEN YOU ARE R.T.I. TRAINED IN

## RADIO-TELEVISION ~ Talking Pictures

**BIG PAY JOBS! SPARE TIME PROFITS! A FINE BUSINESS OF YOUR OWN!** They're all open to you and other live wire men who answer the call of RADIO. The fastest growing industry in the world needs more trained men. And now come Television and Talking Movies—the magic sisters of Radio. Will you answer this call? Will you get ready for a big pay job Now and step into a BIGGER ONE later on? You can do it EASILY now.

### R. T. I. Home Training Puts You In This Big Money Field

Radio alone, pays over 200 MILLION DOLLARS a year in wages in Broadcasting, Manufacturing, Sales, Service, Commercial Stations and on board the big sea going ships, and many more men are needed. Television and Talking Movies open up other vast fields of money-making opportunities for ambitious men. Get into this great business that is live, new and up-to-date, where thousands of trained men easily earn \$60 to \$100 a week—where \$10,000 a year jobs are plentiful for men with training plus experience.

### Easy To Learn At Home—In Spare Time

Learning Radio the R. T. I. way with F. H. Schnell, the "Ace of Radio" behind you is EASY, INTERESTING, really FUN. Only a few spare hours are needed and lack of education or experience won't bother you a bit. We furnish all necessary testing and working apparatus and start you off on practical work you'll enjoy—you learn to do the jobs that pay real money and which are going begging now for want of competent men to fill them.

### Amazingly Quick Results

You want to earn BIG MONEY, and you want some of it QUICK. R. T. I. "Three in One" Home Training—Radio-Television-Talking Movies—will give it to you, because it's easy, practical, and



**FRED H. SCHNELL**  
Chief of R. T. I. Staff  
Twenty years of Radio Experience. First to establish two-way amateur communication with Europe. Former Traffic Manager of American Radio Relay League. Lieut. Commander U.S.N.R. Inventor and Designer Radio Apparatus. Consultant Radio Engineer. Now in charge of R. T. I. Radio Training—and you will like his friendly manner of helping you realize your ambition.

is kept right up-to-date with last minute information. In a few weeks you can be doing actual Radio work, making enough EXTRA MONEY to more than pay for your training. In a few short months you can be all through—ready to step into a good paying job or start a business of your own. A BIG JOB—BIG MONEY—A BIG FUTURE. There is no other business in the world like it.

**Investigate—Send For R. T. I. Book Now**  
Don't waste a minute. Find out what the great Radio Industry, which has grown faster than the Automobile and Motion Picture business, has to offer you. Find out what other men are earning. SEE HOW EASILY YOU CAN GET STARTED. Get the facts about Radio, Television and the Talking Pictures, first hand, in the big R. T. I. FREE BOOK. Learn what this R. T. I. "Three in One" Home Training can do for you. Mail the Coupon for FREE BOOK NOW.

**Radio & Television Institute**  
Dept. 771  
4806 St. Anthony Court, Chicago



## R.T.I. Training Brings Big Jobs Like These!

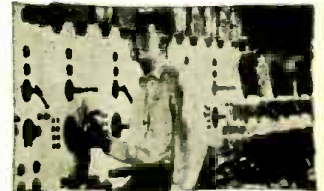

**Earned \$500 Extra Money in Two Months**

Your radio course has enabled me to earn over \$500 in two months' spare time work. Understand that this is all spare time work, as I have a permanent position with my father in our store. I give you all the credit for the above and as I said before, I wish to finish the entire course as soon as I can.—Your student, J. NORRINGER, Greenville, Ky. R. I., Box 37.



**Salary Raised 331-3% Since Enrolling**  
You may be interested to know that I am now Radio Service Manager for the H. N. Knight Supply Co. who are distributors for Eveready Radio Receivers in the State of Oklahoma, and Texas Panhandle, with an increase in salary of about 33 1-3%, since I enrolled with your school.

Thanking you for your interest you have shown in me, and your wonderful course, I am, SART P. GORDON, 618 East 9th St., Oklahoma City, Okla.



**Makes \$25 a Day**

Haven't forgotten you. How could I when I make as high as \$25.00 per day and have made \$600.00 in two months from Radio work. That's not so bad when I'm only 19 and in a small town. I just looked over the catalog you sent me before I enrolled, and you did about all you said you would and about as much more.—FLOYD KIRSELY, R. F. D. 2, Box 91, St. Joe, Ind.

**RADIO & TELEVISION INSTITUTE**  
Dept. 771 4806 St. Anthony Court, Chicago  
Send me Free and prepaid your BIG BOOK "Tune In On Big Pay" and full details of your three-in-one Home Training (without obligating me in any way).

Name.....  
Address.....  
City..... State.....

**R. T. I.** TRAINS YOU AT HOME FOR A GOOD JOB OR A PROFITABLE PART TIME OR FULL TIME BUSINESS OF YOUR OWN

# Presenting . . . The New Editor of RADIO-CRAFT'S SERVICE MEN'S DEPARTMENT



JOHN F. RIDER

Mr. John F. Rider will have editorial supervision of all material submitted to, and printed in the department of this magazine which is devoted to the special needs of the SERVICE MAN. Mr. Rider is already well known to many of our readers, as one of the best-informed and most practical authors and instructors in this phase of radio; and his appointment insures that the SERVICE MAN will find the contents of these pages worth-while reading.

**M**R. RIDER'S active interest in radio has covered a period of some seventeen years; but in 1924, when the era of broadcasting began, he took up the subject as a profession, and applied his knowledge as an electrical engineer to both design and authorship. Throughout the period of radio development since then, he has designed commercial receivers and other apparatus, both as staff chief engineer and as consulting engineer for several manufacturers. He established his own research laboratory and has made extensive measurements on the performance of apparatus; particularly in the field of audio amplification, in which he has done much commercial work.

At the same time, Mr. Rider undertook the work of popularizing radio knowledge. The calculations of radio engineering are difficult for the most mathematical reader; but Mr. Rider possesses the happy knack

of putting difficult things in such a way that they are as easy as possible for the man who lacks formal training in the sciences. For that reason, his contributions have been continually in demand by the radio press. A weekly feature, "The Laboratory Scrapbook," was conducted by Mr. Rider in the columns of the *New York Sun* Radio Section since 1922; and has filled many a scrapbook for serious readers.

The service field, in fact, early impressed its tremendous importance on Mr. Rider, and he has devoted to it a great deal of his attention for the past three years. His latest book, "The Trouble Shooter's Manual," has received a good deal of praise from readers of RADIO-CRAFT. Preceding it have been "Mathematics of Radio," "Design and Construction of 'B' Battery Eliminators," "A.C. Tubes and How to Use Them," and "Treatise on Testing Units for Service Men." All these books are notable for their

practical nature and clear style.

Mr. Rider, with his grasp of the problems of audio amplification, was early active in the field of "talkie" engineering. He is at present associate editor of *Projection Engineering* and of *Radio Engineering*; and a contributing editor to *Motion Picture News*.

Mr. Rider will pass upon all the articles, submitted to this magazine, which deal with the problems of the SERVICE MAN; and we renew the invitation to all our readers to write and tell us their professional experiences, no matter in how plain a literary style. It is the endeavor of RADIO-CRAFT to be a magazine BY the SERVICE MAN, as well as OF and FOR him.—EDITOR.

## Leaves from Service Men's Note Books

*The "Meat" of what our professionals have learned by their own practical experiences of many years*

By RADIO-CRAFT READERS

### \$25.00 Prize Winner SERVICING THE "400"

By Albert Turenne

"THIRD CALL," read the order slip; "Set very noisy; fix it or cancel order."

I crawled out of my car with bags in hands and gazed at the beautiful apartment building with some misgivings. The location was on lower Commonwealth Avenue in the exclusive Back Bay district of Boston.

The set, a Radiola 18 for direct current, had been installed by a fellow service man of more experience than I had; and he also had answered the second call to eliminate or minimize local interference without, apparently, any success. Now I was to try my hand; but I felt little confidence of any improvement, for I knew of the circumstances and conditions in this particular building.

I was ushered into a luxurious suite on the third floor and was glad to find that the occupants were out for the afternoon. I felt

more at ease; if I failed I would not have to face the ridicule of an exasperated patron.

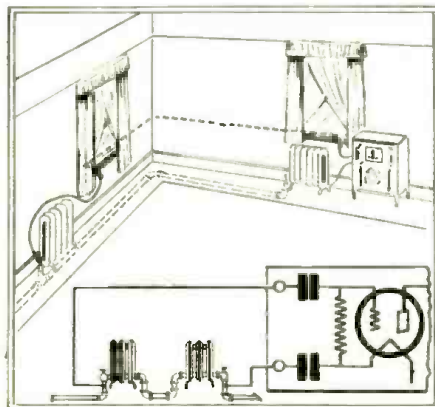

When His Satanic Majesty, King Noise, reigns in the basement, an outside pick-up must be obtained somehow.

### All the Modern Interferences

The situation was this: the apartment is a large nine-story building of steel-frame construction. The owners at the time did not permit an outside aerial to be placed on this building, and the basement here is an enormous network of machinery always on the go—motors for the automatic elevators, the refrigeration system, the oil burners, the laundry, the ventilation fans, and what not.

And while Stations WNAC and WEEI were just across Boston Common, not more than a mile away, I found, when I tuned in these stations, that the studio broadcasts were utterly engulfed by the infernal trying racket from below. When I disconnected the inside antenna I naturally had to increase the volume control to bring in the

station; with the result that the frying noise came in even louder than previously.

I shifted the aerial and ground leads, tried a longer aerial and a shorter one, sent them in different directions, but to no avail. I began to feel quite dejected. If I could shoot an aerial up to the roof my troubles were over, but the management would not permit this. I had serviced a receiver on the seventh floor of this building without being bothered at all by interference. But here, on the third floor, was a different story. To smother all this man-made static would require a formidable aggregation of different capacity filters. It was obvious that the powers-that-be would not countenance such expense; not just yet, anyhow.

#### A Furtive Ruse

There was still a little spark of hope remaining and, throwing all the windows open, I began to string a gray-colored No. 18 rubber-covered stranded wire snugly against the outside wall, running this wire horizontally from window to window just beneath the sills. I reasoned that such a thin, neutral colored wire could not be seen from the



Direct-current house supplies are a source of much grief in these days of alternating-current standards. Particularly when the tyro starts experimenting is there apt to be trouble—even the simple one of polarity.

street, and thus would escape the dictum of the owners.

Around a corner I managed to sling this wire and on to the last window where (instead of ending it there) I fastened the end to a window lead-in strip and grounded the inside terminal of the lead-in to a radiator. The other end of the aerial was connected to the antenna terminal of the receiver, and the ground terminal of the set was connected to another radiator; thus producing a form of aperiodic loop antenna.

Tuning in the set now I obtained perfect reception without noise interference. If I disconnected the outer end of the aerial from the radiator, the noise would again surge in.

I cannot explain this phenomenon, for I was just taking a pot-shot at laying out my aerial in this way; but I will say that this method will not always prove satisfactory.

#### Long Antennas Avoid Trouble

The most frequent sources of disturbance in the many homes I visited came from the refrigeration systems, usually in the basement or in the kitchen, or in the neighbor's

#### \$25.00 EVERY MONTH

Will be paid for the most interesting story by a professional reader, containing his practical experiences and something of value to most other service men. It will appear on this page; together with other helpful contributions, which will be paid for at the regular rates. Send in your story; in any shape so long as it is both understandable and interesting. Address the Editor, RADIO-CRAFT.

house; another sinner is the oil burner. But we seldom have to install filters; running an aerial to the roof usually increases the volume of broadcast reception so that the volume controls of the receiver may be turned down, thereby eliminating the weaker interference. And the receivers used today are generally selective enough to tune out even the nearby stations.

Another word concerning aerials; many tests have convinced us that so-called "cage antennas" and other contraptions are absolutely worthless. Cut off the cage and add a few feet of single wire, and you have exactly the same results.

#### A CHRISTMASTIDE MUDDLE

By George F. Carpenter

THE street mains in the heart of the city of Washington, D. C., furnish direct current; the pole lines on the outskirts of the city furnish alternating current, and thereby hangs a Christmas tale.

The old Georgia colonel's home on B Street, Northwest, was the scene of a lively Yuletide gathering; his husky and prosperous boys and girls with their flocks came to bring their Christmas gifts. Among them, Bill brought Daddy a Balkite trickle charger.

The old Colonel's set was a six-tuber, the joy and pride of the household, built to order by an expert who very cleverly supplied the "A" and "B" current from a power board consisting of Clarostats and Tobe condensers and a couple of chokes which smoothed out all the pulsating ripples.

Bill had an idea that the old Colonel's set was using the "A" battery for filament supply (instead of a part of the filter, as planned) and, with a show of pardonable pride, he produced his trickle charger, filled the jar with the acid electrolyte and said: "Now Dad, no more battery trouble for yours." The old man replied, "I haven't any battery trouble whatever; but if this device will make it any better, why, go ahead."

Bill disconnected the plug which fed the power board, connected the trickle charger to the battery terminals and plugged in his charger on the direct-current wall socket. Soon there was a smell of something burning followed by a puff of ill-smelling smoke that brought consternation to all the group. Bill snatched the current lead from the wall socket and disconnected the trickle leads from the "A" battery terminals. He put back the power plug—correctly, he thought—but he had failed to notice the slot cut

in one side of the plug which denoted correct polarity. The set would not function; wrong polarity. Poor Bill, how was he to know? He didn't have a voltmeter, nor did he know how to get a polarity reading with a potato.

I was hastily summoned by telephone: "Dad is afraid his set is ruined; I'll give you \$20.00 if you'll only have the set working by midnight; please come quick, etc." It was then 11 p.m. There had been a family row and a glance at the centre table told its own tale; there lay the ruined trickle charger—some of the acid had spilled on the top of the beautifully-inlaid mahogany table, and mother was angry.

I went over the power-board panel so nicely secreted in the cabinet; a touch of the test clips on my voltmeter leads told me that polarity had been reversed; I pulled out the power plug, gave it a turn so that the slot showed on top, threw on the power, turned the dials a bit and the loud speaker boomed out. "This is station PWX, Cuban Telephone Co., Havana, Cuba." The old Colonel was jubilant and vowed never to allow anyone to monkey with his set again. The old mother asked me if I could fix it so the colored lights would burn on her Christmas tree and in the dining room; and I happened to have a "Henco" 3-way socket plug in my toolbag which solved her problem. On the stroke of midnight I left the old Colonel's mansion with \$20.00 in my pocket, and listened to the church bells pealing forth their message of peace on earth and good will to men.

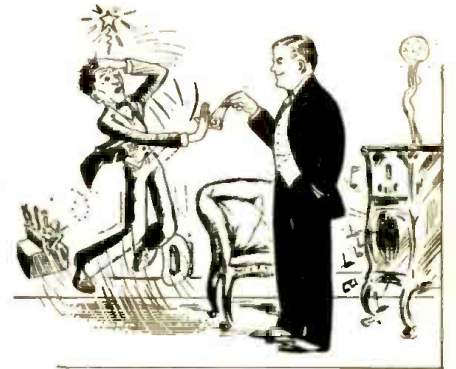

Sometimes the Service Man's money comes easy—with the accent on the "sometimes."

#### A BAD CONNECTION AND A GOOD CUSTOMER

By Randolph C. Michaels

THIS story is told for the benefit of those servicing old-style sets; and dates back to one of the first neutrodyne. I was doing radio then in my spare time, and had my cards widely distributed. I received a call from the proprietor of an ice-cream parlor, who had a five-tube set. He said that he had brought three service men in to look at it, and none of them could fix it. Anticipating a real job, I got out my ear.

On arriving, I first proceeded to test the tubes. Finding them O.K., I started to check the wiring and transformers by using phones and battery. On the third R.F. transformer, I got a click on the two bolts holding the ends of the coil in place; but not on the "C" and "F—" leads from the coil. When I looked at the connections inside

# Radio Service Data Sheet

## BREMER-TULLY MODEL 7-70 AND 7-71

This receiver includes three stages of tuned radio-frequency amplification, neutralized in the "Counterphase" manner. To test this part of the circuit, a continuity tester is used to check the connections which include, (in the circuit V1, for example), L2N, C5, and a few turns at the grid end of L1S. The "micro-mikes" or neutralizing condensers C5, C6 and C7 are located at the right of the respective tube sockets. The procedure of balancing a receiver using the Counterphase neutralizing method will be described. Usually it is convenient to use a vacuum tube with one of the filament prongs shortened so that the filament circuit is open when the grid, plate and one side of the filament are making contact. Now, tune in a loud signal, adjusting all tuning controls very carefully for exact resonance. Replace V3 with the special tube. (Always start with the R.F. stage next to the detector). Retune all controls until maximum volume is obtained. The "micro-mikes" are now adjusted. The best tool for this purpose is a piece of bakelite rod which has been shaped to a screw-driver edge. The correct position for the "micro-mike" of any stage is between the point where the signal disappears and that where it is again heard. Now, replace the dummy tube by V3, retune set carefully, and proceed to the next stage; working toward the aerial. "Micro-mikes" C5, C6 and C7 are located underneath the chassis, directly beneath the holes in the aluminum plates or shields. Condensers C1A and C8 are circuit balancers; C8 is another "micro-mike" adjusted (for maximum volume) with the insulated screw-driver. C1A is operated from the panel as a "sensitivity" control.

1,540 ohms. Condenser C9, 0.25-mf.; C10, 0.25-mf.; C11, 0.5-mf.; C12, .006-mf.; C13, 0.5-mf.; C14, .00025-mf.; C15, .003-mf.; C16, .01-mf.; C17, .00025-mf.; C18, 1 mf., (400 V.); C19, 2 mf., (400 V.); C20, 2 mf., (400 V.); C21, 1 mf., (160 V.); C22, 1 mf., (400 V.); C23, 1 mf., (400 V.); C24, 1 mf., (400V.); C25, .00025-mf.

A special design is followed in the construction of AFT1; the primary is tapped, the smaller portion having the correct impedance for the phonograph pick-up.

Terminals for the reproducer are indicated in the schematic circuit as L.S.

AFT1, AFT2, AFT3 and C16 are housed in a

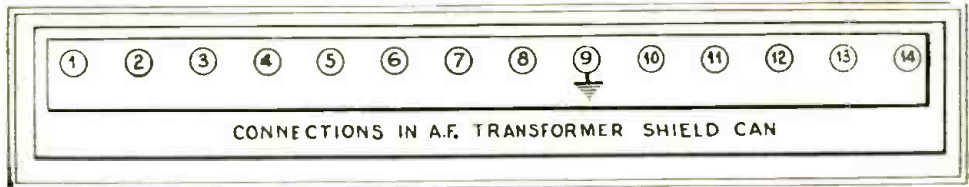

C9, C10 and C11 in one case and C13 in another (C9 and C10 have blue leads and C11 has brown leads, and C13 has a yellow lead), are mounted on AFT shield can, above lugs 9, 10 and 11.

The "resistance network" of the "Power Converter," as the current supply unit is called, has its return circuit to "B-" completed through the internal resistance of the tubes, instead of through an external resistor.

If a magnetic reproducer or separately-excited-field dynamic is used, "jumper" connects posts A and B in power pack; when a high-resistance-field dynamic reproducer is used its field coil may be energized by connection to posts A and B, "jumper" then shorting CH2 by being connected to posts A and C.

### The Color Code

- 1—Green, V1, V2 and V3 filament supply, 1.5 volts;
- 2—Green, same as above;
- 3—Red, Filament supply for V4, V5 and V9;
- 4—Red, same as above;
- 5—Yellow, filament of V6 and V7;
- 6—Yellow, same as above;
- 7—White, "B+" power;
- 8—Green, "B+" for V5;
- 9—Brown, "B+" for V1, V2 and V3;
- 10—Blue, "B+" for V4 (detector);
- 11—Yellow, "B-" and chassis ground.

### Typical Voltage Readings

Tube No.	Tube Type	Voltage "A"	Voltage "B"	Voltage "C"	Plate Current Normal	Grid Test (Ma.)
V1	'26	1.4	150	9	5	12
V2	'26	1.4	150	9	5	12
V3	'26	1.4	150	9	5	12
V4	'27	2.1	60	0	2	2
V5	'27	2.1	150	8	5	8
V6	'71A	4.9	150	30	18	41
V7	'71A	4.9	150	30	18	41

single shield can, the connections being brought to soldering lugs. They are represented in these columns by the numerals one to fourteen in small circles.

The panel switch marked "Tone Control" functions by shunting the secondary of AFT1 with C15 and the primary of AFT2 with C16. Normally, there is a shunt capacity of .00025-mf. connected to the secondary of AFT1; it is C14. One side of the secondary of AFT2 is shunted by C17, the

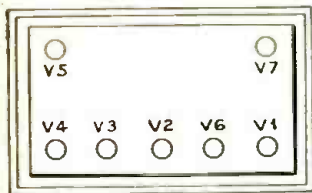

Tube layout of the B-T "7-70" and "7-71."

This receiver is designed to operate at a line potential of 115 volts, and the resulting tube voltages at this line value are given in a table below. If the line potential is below 100 volts, the power pack will not function properly and hum will result; the plate reading of V1, V2 and V3 will be about 1.15 volts.

The electrical values of the units in this receiver are listed below:

Resistors R2 and R3, 40 ohms; R4, 8 ohms; R5, 770 ohms; R6, 4,000 ohms; R7, 1,700 ohms; R8, 34,100 ohms; R9, 1,125 ohms; R10, 3 meg.; R11,

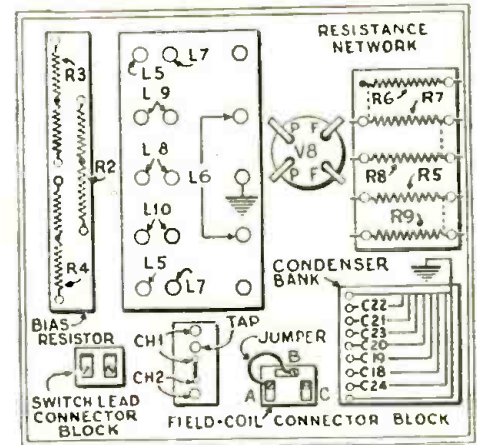

purpose of which is to eliminate oscillation of the push-pull circuit due to variations in tubes when purchased or during the life of the power tubes.

R10 and R11 are tubular resistors connected at the tube sockets.

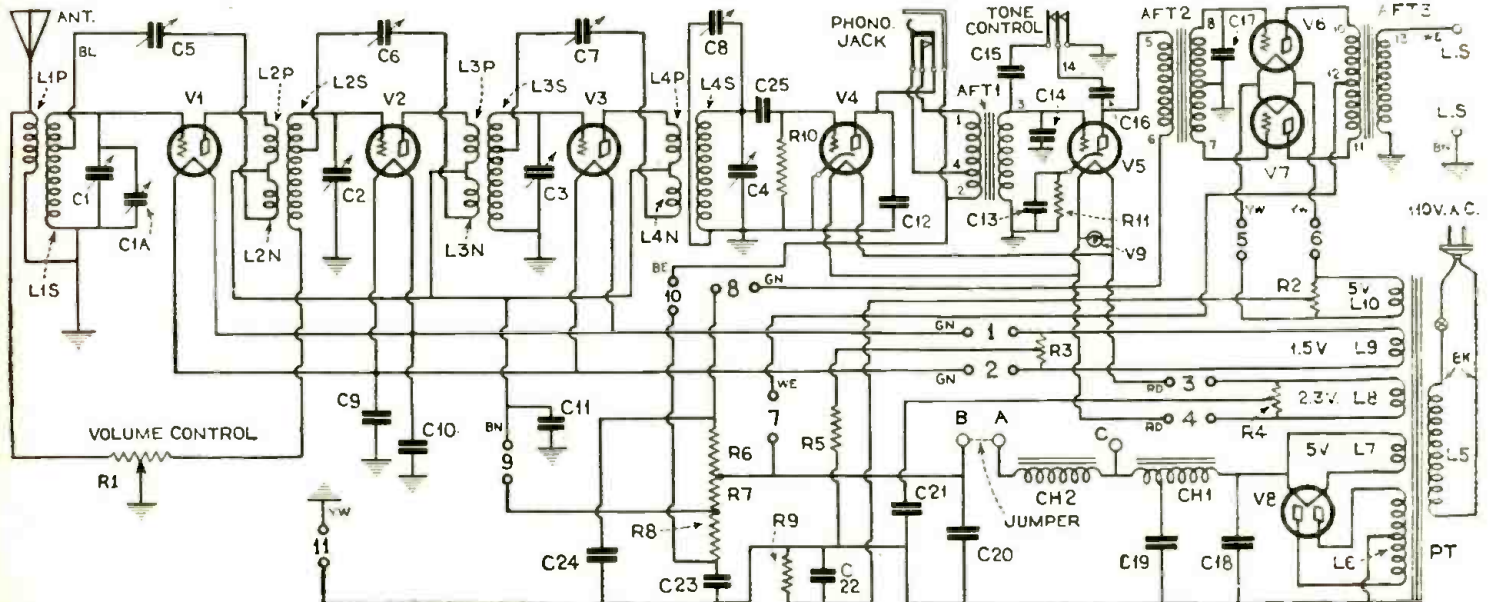

the coil, I found the nut had loosened slightly; and the lug was perfectly centered around the bolt, *without touching either nut or bolt*. I tightened the nut, and the set worked like a charm.

The owner did not ask me what my charge was; but handed me five dollars for my fifteen minutes' work and called it square. This proves that connections are not always as good as they look, and that real service men are in demand.

*(We think that real service customers like the gentleman described in the story are even more in demand.—Editor.)*

**"NAILING DOWN" THE HUM**

By J. E. Bourke

**D**URING lonely watches at sea, with a pair of phones on my ears for six to eight hours at a stretch, your magazine has helped to pass away the lonely hours. I am now getting off the ship to look for a service job ashore again; and I honestly believe that your magazine gets home to the service man better than any of them.

Like most of the old-timers, I have had to perform a lot of "wrinkles" to keep a radio set working; but like most of the others, thought nothing of them at the time. The only objective was "It *must* work." How-

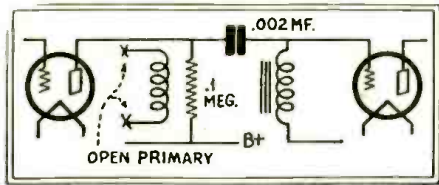

Fig. 1

*An emergency repair with which every radio man should be familiar.*

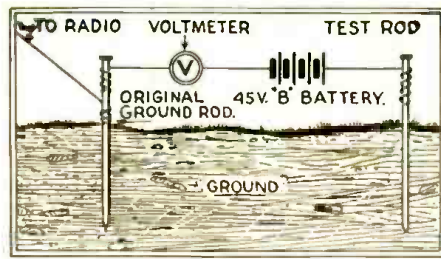

Fig. 3

*Instrumental connections for determining the conductivity of the earth at any given point.*

ever, here is one that you and thousands of others know, undoubtedly.

On the voyage to Australia, about three months ago, we ran into a heavy electrical storm; and the junior on watch did not "ground" the antenna. At two in the morning, I was called to see why the receiver was dead. After a while, I found that the lightning had burned out all the primaries in the entire circuit, of both the R.F. and the A.F. transformers—a very peculiar happening and one that will never happen again.

My cure was the old-time favorite; that is, a .002-mf. condenser and a 100,000-ohm resistor in the primary circuit of each of the disabled transformers, as sketched. With this arrangement, we were able to copy nearly as well as before; and got all the press and weather reports, during the remainder of the voyage. (See Fig. 1.)

Here's another: while employed ashore in the service game, I came across a case where two employees had been discharged because they could not satisfy an irritable customer who complained of an A.C. hum. Like most of them, he wanted his money back; and this was well-nigh impossible, for it had been a cash sale. So I was employed and

given this job for a week, to fix him up. The set was a Stromberg-Carlson of an early A.C. type, with separate "B" supply. After two days of trying all conventional remedies, my remedy was as follows:

I drove three ten-penny nails in between the laminations of the power transformer, and away went the hum. (No matter how tight the binding straps were taken up, they did not tighten the laminations at these two points.) And, so, I was permanently hired, until I got the sea fever again.

**THE "LACK OF VOLUME" COMPLAINT**

By Delbert Myers, A. I. R. E.

**M**ANY complaints of lack of volume in receiving sets, which have been installed for a year or so, may be traced to *carbonized or grounded lightning arrestors*. A set may test perfect on the bench, yet give scarcely any volume at the customer's home, where the aerial is grounded through an arrestor.

To test for a ground in the arrestor, take your continuity tester (headset and battery), loosen the aerial and ground leads, (Continued on page 338)

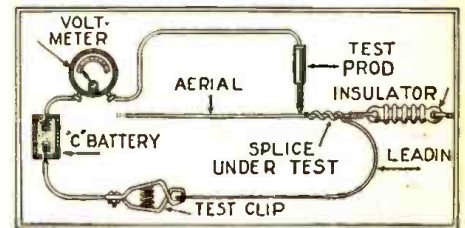

Fig. 2

*Using a voltmeter as an ohm-meter, to check the contact between aerial and lead-in.*

**The Service Man's Open Forum**

**EMERGENCY REPAIRS MAKE GOOD WILL**

**T**HE October issue has just arrived, and I wish to take this opportunity to congratulate you on the Service Data, particularly on the fact that the constants are given to the diagram. To the service man, who is really interested in his profession, this information is important; as it very often enables him to make a diagnosis; when without it, that set would have to be laid up until parts could be obtained from the maker. This usually entails considerable delay; and, even when local sources of supply can furnish the necessary parts, it often happens that the call for service will come in the evening, or on a Saturday night. By replacing the defective part, even if it must be by an external connection, the set is kept in operation over the week-end; and this is worth much in good will to the service man and his shop.

B. B. ALCORN,  
Kew Radio-Electric, Inc.,  
Kew Gardens, L. I.

*(It must be admitted that the receiver which is most satisfactory to service is the one which the service man will recommend; and service diagrams are no small factor toward reducing the labor of servicing.—Editor.)*

**ON PAGE 309**

Is a blank which every Service Man should fill out, for his own protection and advancement. If you can qualify, **"DO IT NOW"**

**A REPROOF FOR THE QUICK REPAIRER**

**B**EING an old reader of your magazines, from 1908 on, I am giving you a calling down for letting rubbish like "How a Service Man Does It" get into the October issue of RADIO-CRAFT. This should be entitled "How Not to Do It." It's nothing but a botch job and fixing (?) transformers in the manner shown will lose some good customers. A transformer repaired in this manner will give very poor results, if any. The maker of any transformer counted those turns, if he made it properly; and he did not put in a few dozen extra for luck. Forming an arc will, ten chances to one, cut out more than a dozen turns and probably cause a ground. I think this kind of fixing is taking too many chances with the customer's set.

I have been repairing all kinds of electrical machines since 1906 and, in the days long

ago, when transformers cost real money. I fixed them when burnt-out by rewinding. Now I seldom do this; it is cheaper to install a new one and credit the old one to loss. The same applies to condensers, etc.

When I go out to do repair work, I take a repair kit with a little of everything in it—condensers, transformers, etc., depending on the type of set I am going to inspect. If a transformer is burnt out, I install a temporary one, using spring clips, until a duplicate is obtained, if I have none on hand.

It would take an awfully long letter to tell of all the thousand and one things, short cuts, etc., I have learned in the past twenty-three years; but, to sum up—to test and locate faults in a radio receiver or any other electrical machine—all you need is an ounce of common sense and a certain amount of electrical knowledge.

I wish you the best of health and success. My greatest desire is to see something in RADIO-CRAFT by Mr. Tesla, the father of radio and to my mind, the greatest inventor and scientist the world has known. Where is he?

A. H. MATTHEWS, E.E.  
46 De La Ronde, Limoilou,  
Quebec, P. Q., Canada.

*(Mr. Matthews' praise, in this case, pleases (Continued on page 339)*

STEINITE 50-A AND 102-A

On the terminal strip of this receiver are mounted: the power-cable lugs; the grid leak and condenser; the detector-plate by-pass condenser; the two center-tap resistors; and the 600-ohm and 2500-ohm "C-bias" resistors.

A special input circuit is used on the Steinite receivers, for the purpose of obtaining sensitivity. The circuit acts as an autotransformer when the antenna lead is connected at the junction between L1 and C1. The purpose of R1 is to complete the D.C. path for the grid bias.

clockwise position cuts in 75,000 ohms additional. The resulting biasing potential is sufficient to reduce the plate current to nil; and even powerful local signals are cut out.

The output transformer matching V6 and V7 to the moving coil of the dynamic reproducer is built into the reproducer. The primary winding has a resistance of 285 ohms between center tap and each end. The secondary winding matches the low-resistance voice-coil.

The power pack of this receiver is built on the

drawing the four screws which secure it to the cabinet, permitting the entire assembly to be pulled out from the back of the cabinet and making easy access to the six bolts which secure the chassis to its supporting-shelf.

If the volume control does not function, consideration of the schematic circuit indicates that the trouble may be due to a shorted C2 or C3.

If the transformer's filament windings for V4-V5 V8-V9 are making contact or flashing over, resistor R2 (situated under the terminal strip and colored red) will be burnt out and consequently show an open circuit, or no "C" voltage on the grid of V5. The remedy for this condition is to remove the transformer from the power pack and substitute another. Only early models should require this repair.

The phonograph turntable should rotate at the standard speed of 78 r.p.m.

Any hum which may develop is ordinarily traceable to the detector; particular care taken in the selection of a detector tube when first setting up the receiver will result in best operation over an extended period.

Variation from the standard circuit to include connections for the phonograph-radio switching arrangement on the 102-A is illustrated; the schematic is laid out to correspond with the view of the switch escutcheon, which is a rear one.

The aligning condensers of this receiver, shown in the parts layout, are not shown in the schematic circuit.

Line voltage tap colors of pack are: red, 90; white, 100; blue, 110; green, 120.

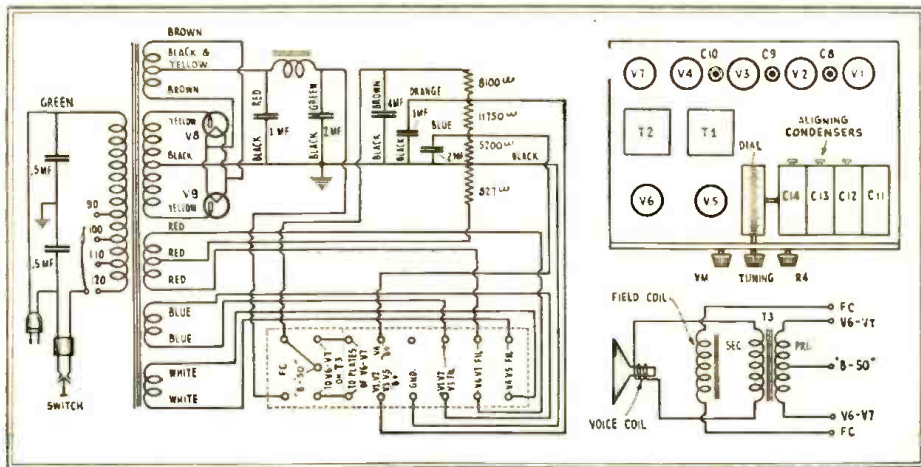

Power-pack parts layout and reproducer connections of the Steinite "50-A" and "102-A."

Each unit of the four-gang condenser has a capacity of 380 mmf., maximum, and 30 mmf., minimum. The secondaries L3, L6, L9 consist each of 8734 turns of No. 30 enameled wire on a tube 1/4-inch in diameter. They are connected in series with the balancing coils (L4, L7, L10) which are wound with 32 turns of the same size wire; they are placed at the low-potential ends of the secondary coils, and in non-inductive relation. The primary coil, placed inside the main secondary, consists of 24 turns of space-wound No. 38 advance wire.

When the volume control R4 is turned entirely "on" in a clockwise direction the bias on the R.F. stages is normal (600 ohms in the cathode leads); turning this control to its maximum counter-

clockwise position cuts in 75,000 ohms additional. The resulting biasing potential is sufficient to reduce the plate current to nil; and even powerful local signals are cut out. The output transformer matching V6 and V7 to the moving coil of the dynamic reproducer is built into the reproducer. The primary winding has a resistance of 285 ohms between center tap and each end. The secondary winding matches the low-resistance voice-coil. The power pack of this receiver is built on the drawing the four screws which secure it to the cabinet, permitting the entire assembly to be pulled out from the back of the cabinet and making easy access to the six bolts which secure the chassis to its supporting-shelf. If the volume control does not function, consideration of the schematic circuit indicates that the trouble may be due to a shorted C2 or C3. If the transformer's filament windings for V4-V5 V8-V9 are making contact or flashing over, resistor R2 (situated under the terminal strip and colored red) will be burnt out and consequently show an open circuit, or no "C" voltage on the grid of V5. The remedy for this condition is to remove the transformer from the power pack and substitute another. Only early models should require this repair. The phonograph turntable should rotate at the standard speed of 78 r.p.m. Any hum which may develop is ordinarily traceable to the detector; particular care taken in the selection of a detector tube when first setting up the receiver will result in best operation over an extended period. Variation from the standard circuit to include connections for the phonograph-radio switching arrangement on the 102-A is illustrated; the schematic is laid out to correspond with the view of the switch escutcheon, which is a rear one. The aligning condensers of this receiver, shown in the parts layout, are not shown in the schematic circuit. Line voltage tap colors of pack are: red, 90; white, 100; blue, 110; green, 120.

The average voltage readings (as shown by a standard set analyzer) for the 50-A and 102-A are given in the table which follows:

Readings of Tester with Test Plug in Socket of Set

Tube No.	Tube Type	Tube out of Tester (Volts)	"A" (Volts)	"B" (Volts)	"C" (Volts)	Nor- mal Test (Milliamperes)	Grid Test (Milliamperes)
V1	'27	2.75	134	2.45	125	6.5	4.25
V2	'27	2.75	134	2.45	125	8.7	5.0
V3	'27	2.75	134	2.45	125	8.7	4.8
V4	'27	2.65	92	2.40	32	.....	2.5
V5	'27	2.65	144	2.40	118	8.2	3.6
V6	'50	7.7	355	7.40	310	51.0	36.0
V7	'50	7.7	355	7.40	310	51.0	36.0

These values were determined with a line-voltage of 110 and with the line-voltage tap on the power transformer set at 110 V. (Volume Control position "Max.")

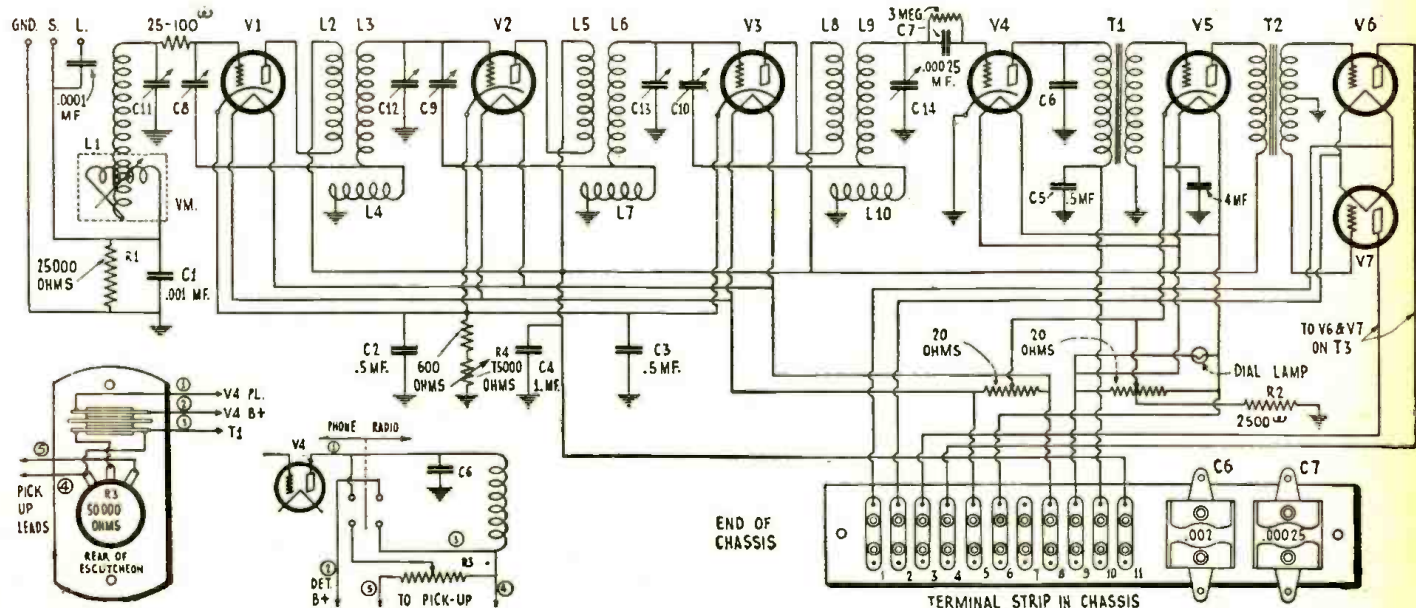

# Servicing the Freshman "Model N"

*In this article, the second of a series, Mr. Weiler not only goes into detail about the work of checking up on the receiver named, but gives many hints of general value*

By HAROLD WEILER

THE second receiver to be described is the Freshman "N." This model has an untuned antenna stage; being untuned, this tube amplifies everything and it is claimed, by some technicians, that its use results in greater broadness of tuning and increased interference from static. However this may be, the connection serves excellently to prevent the variations,

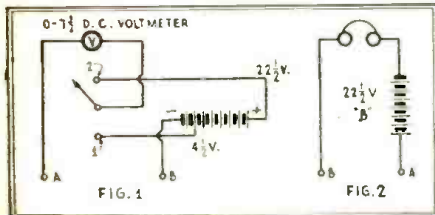

Schematic circuits of two simple test units which will be valuable in the service man's kit.

always found in antenna installations, from reacting on the tuning circuit; which would unbalance the circuit resonance at certain points in the tuning range. The untuned stage is followed by two of tuned radio-frequency, using '26 tubes stabilized through the use of the "Equaphase" method of neutralization (the stabilizing resistor is 730 ohms, tapped at 350 ohms. It is to this tap the "B+" connection for that particular tube is made. There are three of these stabilizers); a tuned detector, using the grid-leak-and-condenser method of detection; and, finally, two audio stages, employing a '26 for the first and a '50 for the last.

Now we will get down to the real analysis of the set. If there is a loss of selectivity it can be attributed to too long an aerial. The remedy is to shorten this. Defective tubes, also, may cause broad tuning, and the remedy is to replace with others having proper characteristics.

A condenser which shorts in one or more positions may cause the broad-tuning effect, in a gang control; and the remedy is to bend the plates which touch, until they clear, or else replace the variable condenser. For test of a shorted volume control, use the continuity tester shown in Fig. 2; if the short is visible, repair it. So much for the selectivity problem.

### The "Alcohol Rub"

If the set is noisy, use apparatus described in Fig. 2. Put lead "A" on antenna post and lead "B" on ground post. Rotate volume control. If there is noise in phones, clean arm and resistance strip with alcohol or whiskey; preferably, the former. (This may "sound" like a joke, but it isn't. Ask

a customer if he has any alcohol you can use, and he will probably offer liquor—which he has had for "medicinal" purposes, of course.) Next, put lead "A" on grid post of '27 socket. If noisy, replace the 3-meg. leak (although, before replacing try condenser alone—without leak.) The detector grid condenser has a value of .00025-mf.

To test transformer primary in first audio, put lead "B" on terminal marked 1 in Fig. 3, and lead "A" on plate post of '27 socket. For primary of second A.F. transformer, change "B" lead to No. 2 in Fig. 3, and put lead "A" on plate post of first audio socket. For secondary of first audio, place "B" lead on ground post and lead "A" on grid post of first audio socket. For second A.F. secondary, leave "B" on ground and put "A" on grid post of second A.F. socket. If there is any noise in phones during these tests, take the defective unit out and heat it care-

To test for open transformers, volume control, grid leaks, or shorted grid condenser, use same procedure; but test with the continuity tester shown in Fig. 1.

Occasionally we get a "snap"; that is, a service call which is very simple, such as for a dial light which fails to do its duty. If the lamp does not light, it may be due to three things: (a) a bulb which has run its limit (b) a burnt-out 22-ohm series resistor (remedy, repair or replace); or (c) excessive voltage due to a shorted series resistor (remedy, remove short or replace with another resistor). As an emergency repair, a 25-ohm rheostat may be substituted

### Power Pack Tests

Now to the power pack. If your '27 does not light, put lead "A" of continuity tester on No. 3 terminal in Fig. 3, and "B" lead on No. 4. The meter should show a reading. If none of the radio-frequency tubes light, put "A" lead on No. 13 and "B" lead on No. 14; meter should register. If first audio is unlit, put A on terminal 5 and B on terminal 6; reading should be obtained. If '50 does not light, put A on 7 and B on 8. So much for the filaments.

### Grid and Plate Potentials

If no grid-bias reading is obtained on the R.F. tubes, "A" lead of Fig. 1 tester goes on No. 15; "B" on ground end of R.F. transformer which does not show a bias voltage. Lack of continuity indicates a poor connection on coil or else, the 500-ohm grid-bias resistor is "shot." No bias on first audio calls for lead "A" on No. 19 and "B" on grounded condenser can. If no continuity, replace 1,800-ohm resistor (this is the black spaghetti-covered lead on condenser can). No bias on '50 tube is checked by "A" on

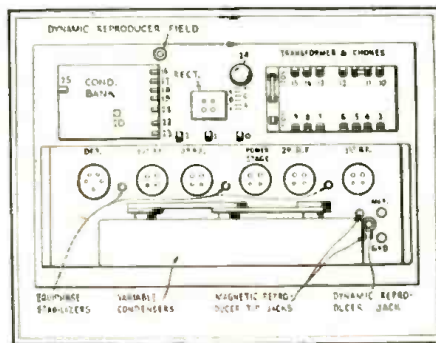

Fig. 3

Layout of the "Model N" and its power pack, indicating numbers of terminals mentioned.

fully on a stove; this should drive out moisture. If the transformer is still noisy, replace with a new one.

Fig. 4

Charts such as this one, which is filled out with the readings obtained from actual analysis of a "Model N," are very useful as a guide to the characteristics of a set; and a valuable record to be consulted in case of a subsequent call. Such charts are obtainable from the manufacturers of set testers, at a low price in quantity.

RADIO SET ANALYSIS												
OWNER		DATE 7/24-29										
ADDRESS		NAME OF SET FRESHMAN "N"										
TUBE NO. IN ORDER	TYPE OF TUBE	POSITION OF TUBE IN SET BY DET. ETC.	TUNE OUT				READINGS, PLUG IN SOCKET OF SET					
			A VOLTS	B VOLTS	C VOLTS	D VOLTS	TUBE IN TESTER	PLATE CHANGE	PLATE M.A.	GRID M.A.	BIAS	RESISTANCE
1	226	1 <sup>st</sup> RF	1.45	100	1.35	90	6	—	3.2	7.4	4.2	—
2	226	2 <sup>nd</sup> RF	1.45	100	1.35	90	6	—	3.2	7.4	4.2	—
3	226	3 <sup>rd</sup> RF	1.45	100	1.35	90	6	—	3.2	7.4	4.2	—
4	227	DET.	2.40	65	2.25	50	0	—	2.2	2.2	0.0	—
5	226	1 <sup>st</sup> A.F.	1.45	100	1.35	90	6	—	3.2	7.4	4.2	—
6	250	2 <sup>nd</sup> A.F.	7.40	350	7.20	300	50	—	36.0	43.5	7.5	—
7	281	RECT.	7.50	—	7.20	—	—	—	46.0	—	—	—

LINE VOLTAGE 119 DET ON 120 VOLT TAP VOLUME CONTROL POSITION

SUGGESTIONS OR CHANGES MADE

TESTED BY H. Weiler



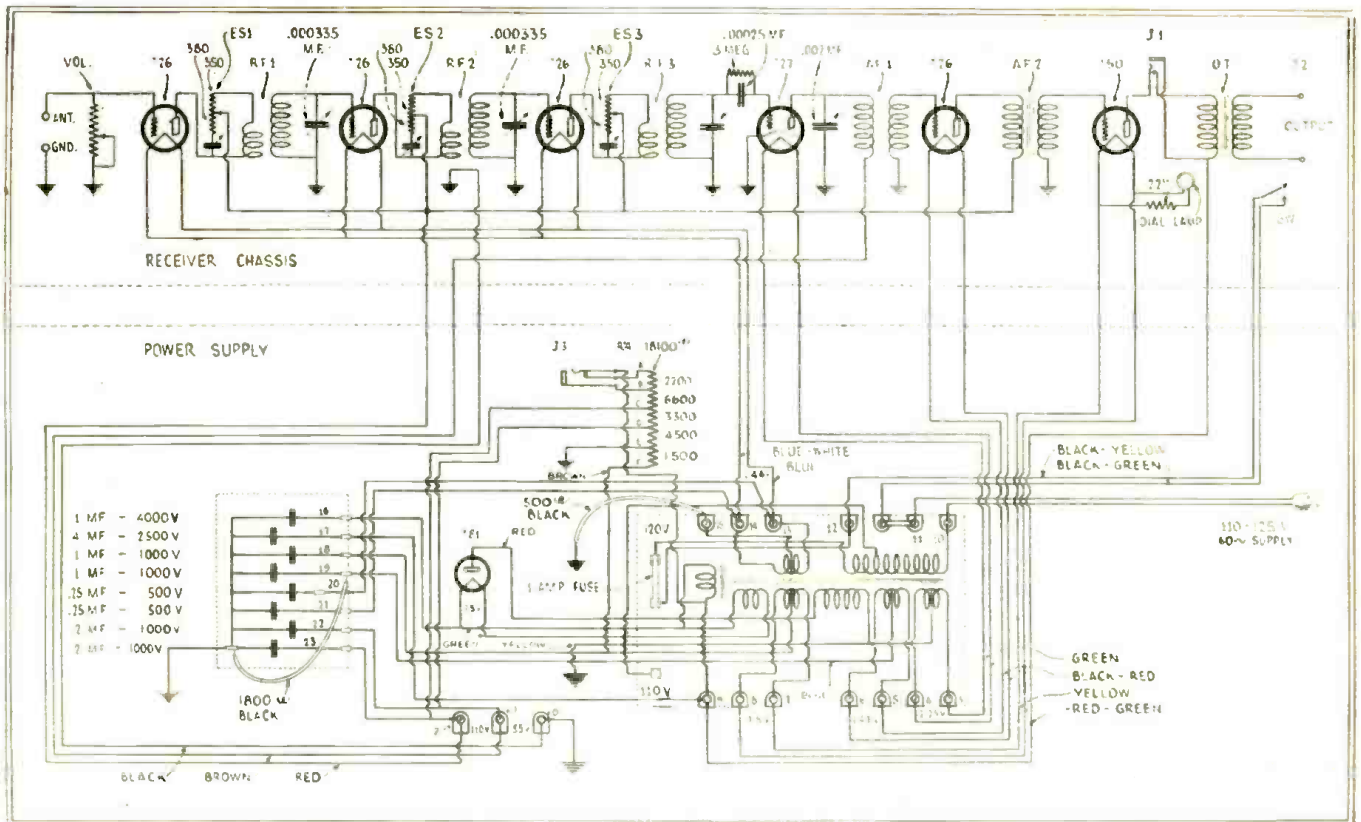

Fig. 5

The Freshman "Model N" and its power pack; the numbering of the terminals shown here may be compared with that in the diagram of the layout on the preceding page. The capacities and ratings of the condensers in the power unit are shown opposite each, respectively, at the left. Note the special 1800-ohm resistor lead shown here.

No. 18 and "B" on grounded terminal of resistor shown as 24 in Fig. 3. If defective, it is to be replaced with a good 1,500-ohm unit.

The "B" potentials are next checked. If test shows no voltage on the detector, when tested with the high-resistance voltmeter connected between 0 and 1, it should be followed by connecting the continuity tester between 24C and 24D; "A" on the former and "B" on the latter. If open, replace with 3,300-ohm resistor; if detector reading is too high, this portion is shorted. In case of no R.F. or first A.F. voltage, test between 24B with A and 24C with B; if open, it is the 6,600-ohm resistor which has gone. If detec-

tor portion or first A.F. section is shorted, get an 18,100-ohm (net) resistor, tapped at 1,500, 6,000, 9,300, and 15,900 ohms.

The condenser bank consists of one 1-mf. (4,000) section, No. 16; one 4-mf. (2,500) No. 17; one 1-mf. (1,000) No. 18; one 1-mf. (1,000) No. 19; one 0.25-mf. (500) No. 20; one 0.25-mf. (500) No. 21; two 2-mf. (1,000) Nos. 22 and 23. (Figures in parentheses are the working voltage ratings.) Test with "A" lead on any of above numbers and "B" on the grounded terminal of condenser can, after removing all "+" leads from the condensers.

Test from plate of '81 to ground to check high-tension transformer, using "A" and

"B" leads to test choke; "A" lead on "F—" post of '81 choke, and "B" lead on No. 9 of Fig. 3.

**Color Code**

The color code used in this receiver is as follows: (Note that while an A.C. circuit has, of course, no polarity, sockets are often marked with distinguishing letters.)

First R.F. "F—" post, blue and white; first R.F. "F+" (A.C. voltage, 1.44), blue; detector (2.25 volts) green; first A.F., (1.44 volts) black and red; second A.F. (5 volts) yellow. The plate circuit includes the negative or "0" of Fig. 9, which is black; No. 1 (55 volts) is brown; No. 2 (110 volts) is red; No. 9 (350 volts) is red and green.

## Reproducers and the Output of Power Stages

IN estimating how many speakers may be employed with a power amplifier for best results, the engineering staff of the Radio Receptor Company, New York, suggests that three-quarters of a watt be allowed for each magnetic cone, two to four watts for each dynamic cone, and five to eight watts where an air column is used with a dynamic unit. This energy is, of course, in terms of undistorted output from the amplifier.

To make this practical, it may be pointed out that the undistorted maximum output of a '71A tube with 180 volts on the plate and 43 on the grid (A.C. operation) is 700 milli-watts, or about three-quarters of a watt. That of the '10 tube with 425 volts on the plate is twice as great—a watt and a half—

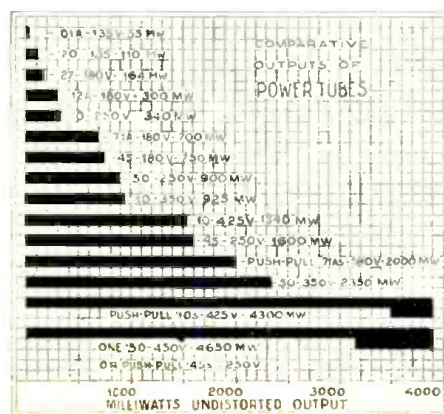

and this is slightly exceeded by the new '45 with 250 volts "B" and 50 "C." The '50, the largest of receiving tubes, has a watt and a half at 300 volts plate; two and a third watts at 350; three and a quarter at 400; and more than four and a half at the maximum of 450 volts with a grid bias of 84.

When two matched tubes of any of the types described above are used in *push-pull*, the level of *undistorted* output is more than doubled; because the tubes working together in this circuit mutually correct certain causes of harmonic distortion. The output of the two tubes, therefore, may be computed for this purpose as 2.8 times that of one only—or, say, about two watts for two '71A's in *push-pull*.

# Operating Notes for Service Men

*An article full of practical hints on the different characteristics of various models, gleaned by a service man of wide experience. Over a dozen makes of sets are described.*

By BERTRAM M. FREED

**R**ECENTLY the writer has had the experience of installing a Victor Combination in an apartment house on West End Avenue, New York, where direct current only was available. This was utilized by the use of a converter to give an A.C. power supply; an ungrounded choke-and-condenser filter; two 8-mf. condensers, in series and shunting the line with a choke in each line—grounding center tap to chassis or ground increased the hum—was placed *after* the converter, in the line to the set. It was found impossible to operate the set, when an aerial about a hundred feet long was used, because of the tremendous noise pick-up. With a sensitive loop set this interference could be detected on the roof (strongly, near a water tower) and (weakly) down into the court where the lead-in was installed, but principally within the building itself.

The outside interference was eliminated by the erection of an aerial 400 feet long, suspended (away from the offending water tower) between the building in which the set was installed and the water tank on the top of a 20-story apartment house, some distance away. The aerial was elevated about 200 feet, and was free and clear of obstructions. The interference in the court was taken care of by using for the lead-in shielded wire, grounded at both ends. (Although this, to some extent, by-passed the signal, it acted to a greater extent as an interference shield.)

However, interference on the *lower wavelengths* was still strong. The interference

stopped entirely when the A.F. amplifier was switched to "phonograph," or when the antenna was disconnected (the latter test eliminated the converter as a source of trouble); touching the antenna post brought in a powerful local, faintly, but the interference came in still stronger, and a coil of wire dropped on the floor, with an end connected to the aerial post, greatly increased the noise pickup; apparently it was an inside problem.) The converter was placed inside a closet, opening into another room; and duplex lead-sheathed wire was run to the set for the D.C. power switch and the A.C. supply. *Another* filter was put in the A.C. line *ahead* of the converter; so that we now had one filter for the D.C. and another for the A.C. These changes, the result of many tests, helped a great deal; but noise on the *lower wavelengths* was still very strong, and the short-wave stations were hardly audible.

After much labor and experiment, a solution that solved 95% of our interference was found. The lead coming from the window to the set ran through a large room, a foyer, and then through another large room to the set. It was determined that the noise was being picked up *in the room housing the receiver*; and the only one in which it could be placed. The inside lead was pulled up; and in its place there was brought from the window to the set a double twisted lead, one wire of which was grounded at both ends. This eliminated practically all noise, and the lower-wavelength stations came in loud and clear.

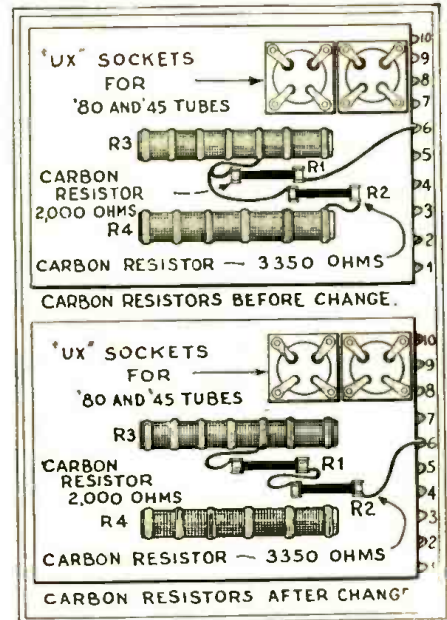

Fig. 2 (top) Fig. 3 (bottom)  
The original connection of the Radiola "44" power pack above; the later connection is shown below.

### Set Peculiarities

The Stromberg-Carlson "523" and also the "734" radio sets have one choke, L9, in the *positive* side and two, L5 and L6, in the *negative* lead of the power pack. (Fig. 1.)

The choke L9 is the plate choke located in the plate circuit of the output tube and passes the direct current consumed in the plate circuit of the output tube. C8 is the speaker coupling capacity feeding into the speaker through the audio filter C6, C7, L8.

With the Atwater Kent "41DC," sharper tuning and greater pick-up may be secured by either shorting or removing the resistor in the plate circuit of the first R.F. amplifying tube, which is located near the tube and the antenna coil.

The Sparton "301DC" employs six '27 tubes, just as does the A.C. model; it consumes 180 watts.

The Bosc "48DC" employs the same tubes as the "48AC" except in the output stage, where the former uses '71As.

The Stromberg-Carlson "635" has condensers across the A.C. input line; check these if the line fuses blow. (See Fig. 1, which shows a similar connection.)

The new Radiola "44" and "46" receivers use three '24s, one '45, and one '80. The "power detector" is resistance-capacity-coupled to the single '45 stage of audio amplification. In earlier shipments these sets

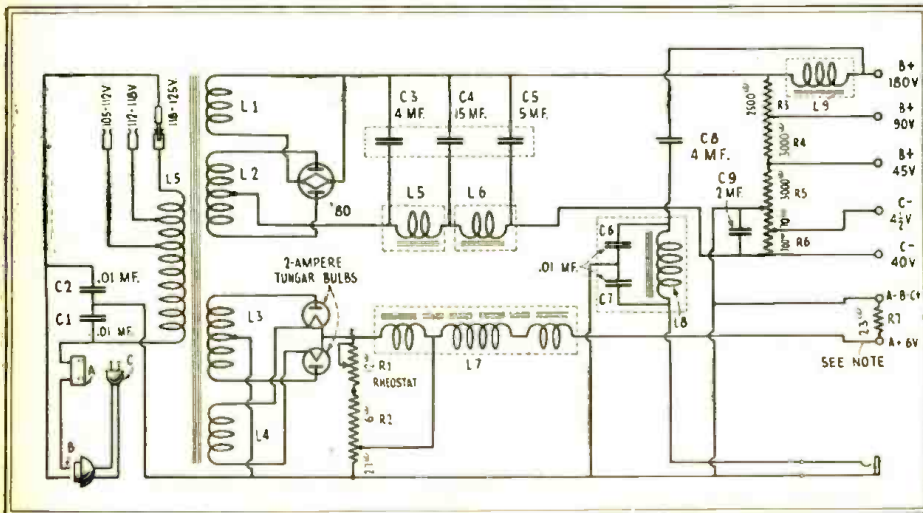

Fig. 1

In this circuit of the Stromberg-Carlson Model 403 and 403A Audio Power Pack is illustrated the connections of the Models 523 and 734 particularly referred to by the author.

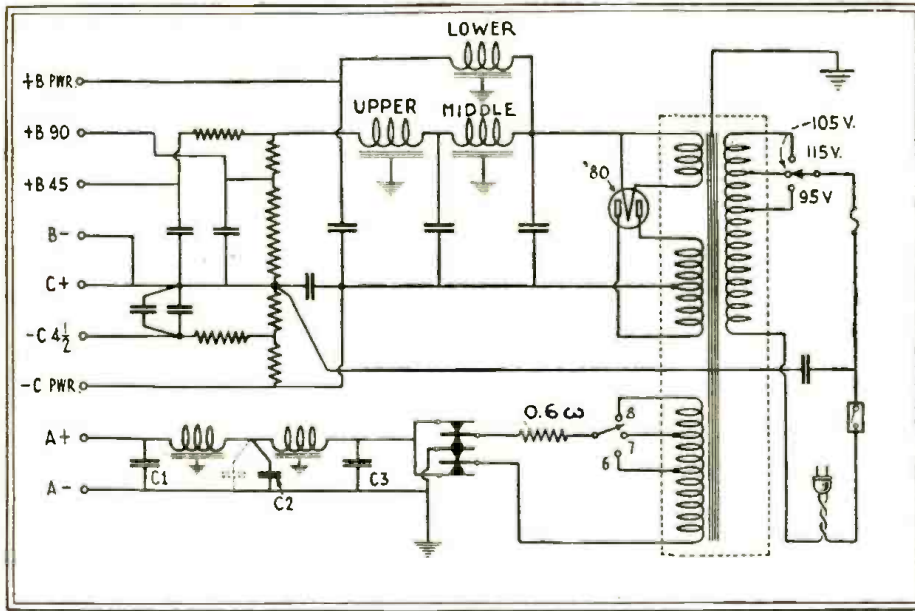

Fig. 5

"ABC" six-volt tube-supply unit of Fada types "86-1" and "82-W," illustrating an application of the 1500-mf. dry "L" condensers.

included a resistor strip in the power pack, the connections to which were not correct for best results. The connection employed in the early models is indicated in Fig. 2. The improved arrangement in Fig. 3.

"Plays, but Lacks Volume"

In Fig. 4 is illustrated a peculiarity of the Bosch "28" and "29." Resistor R1 is the

usual grid leak; R2 is a plate voltage control resistance. The customer will report, "My set plays, but there is no volume." Look for an open circuit in this resistor. It is pointed out that this 50,000-ohm resistor reduces 90 volts to the value required for the detector tube, being connected from the "B+" terminal of the first A.F. transformer, to the "+ 90 V" supply

## Prescriptions of a Radio Doctor

By PAUL L. WELKER

WHEN testing plate voltages on A.C. tubes, the mistake is often made of placing the meter across the "B" supply in order to determine the plate voltage. This reading does not give the true plate voltage; instead, plate voltage plus the grid voltage will be registered. To obtain an accurate measurement of the plate voltage, it is necessary to connect the meter V between the plate terminal of the tube socket and either filament terminal ("X" type of tube or the cathode, in a "Y"-type tube) as illustrated in Fig. 1. The reading is then the total voltage, minus the voltage "dropped" across the "C-bias" resistor.

A recent experience with a Bremer-Tully receiver illustrates a condition prevalent in many installations. The receiver in question employs type-26 tubes. These tubes

were changed in the receiver and the hum increased to an annoying level. The most frequent source of such trouble is lack of balance in the filament circuit. This receiver made use of a fixed filament shunt resistance with a fixed centre tap. In view of the fact that circuits and tubes are different, the fixed centre tap resistance does not always fulfill balance requirements.

The filament shunt resistance in use was replaced with a variable centre tap element, which was then adjusted for minimum hum. The setting was decidedly off centre. Such conditions exist in many receivers and we suggest that fixed centre tap resistances associated with the filament type of A.C. tube be replaced with a variable centre tap unit. The same applies to systems which involve centre tapped transformers. These centre taps are located according to the number of turns in the winding and are not always the electrical centre. A variable centre tap resistance when correctly adjusted for minimum hum will invariably afford superior results. Fixed centre tap resistances are not required with the cathode type of A. C. tube (Fig. 3).

The resistor values indicated in the diagram are as follows: R1, R2 and R3, 770 ohms; R4 and R5, 8 ohms; R6, 15 ohms; R7, 3 meg.; R8, 40 ohms; R9, 3,000 ohms; R10, 5,500 ohms; R11, 4,900 ohms.

A filament transformer with a 7 1/2-volt, winding had, in an emergency, to be used for lighting two '71A tubes. In order to

lead, the remainder of the resistors being in the pack.

When making continuity tests on the Majestic "91" and "92" repairmen should not be disturbed by the 309-volt reading on the '27. This tube functions as a power detector. 309 volts is the correct potential reading at the tube socket.

Sonora receivers which "oscillate," that is, have an oscillating R.F. amplifier stage, can be cured by connecting a 1-mf. condenser from the R.F. "B+" terminal, to ground.

When testing Philco, Silver-Marshall and some other receivers with dynamic speakers, look in the reproducer housing for the output transformer, instead of near the push-pull tubes in the set chassis.

Fada makes an "A-B-C" power supply unit using three Elkon, 1500-mf. "dry" condensers in the "A" filter system (Fig. 5). If a very bad hum is heard in installations using this power unit, check the "dry" condensers, C1, C2, C3. The trouble is most conveniently checked by disconnecting one condenser after the other, until the hum suddenly drops. As the hum is less with all the condensers out of the circuit, than with a single defective condenser in circuit, the location of the defective unit is simple.

The New Victor sets have a very low hum level. Consequently, an excessive hum instantly indicates a fault in the receiver. Check up the 2,000-ohm resistor between the cathode of the detector ('27) and ground. If this is open, you have located the cause of the hum.

(Continued on page 339)

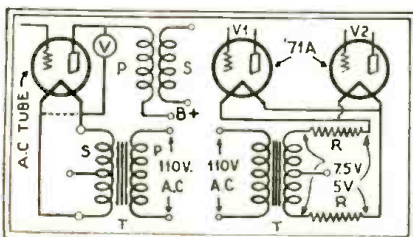
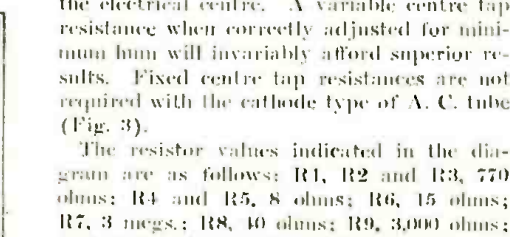

Fig. 1

Left: Obtaining correct plate-voltage reading.

Fig. 2



Right: Balancing reduced filament potential.

cut the voltage down to 5, a resistor R was placed in series with each secondary lead; if only one resistor were used in series with one of the leads, the electrical balance would be destroyed. The two '71-A tubes draw half an ampere of current and the resistance required in each leg is 2.5 ohms; since the drop required is 2.5 volts at .5 ampere. This method is shown in Fig. 2.

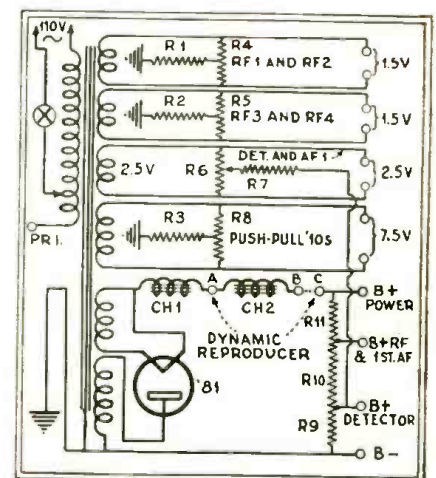

Fig. 3

The necessity for the schematic circuit when servicing receivers is obvious with a "kink" such as the use of resistor 7 above, in the power pack of the Bremer-Tully "8-20-A."

# A Complete Portable Radio Testing Laboratory

## PART I

*A two-part story covering the construction of an exceptionally complete circuit analyzer and instrument tester. Parts used by the author are listed, but electrically equivalent units may be substituted by the constructor.*

By GEORGE C. MILLER, Associate, I.R.E.

**A**FTER trying practically every factory made radio set and tube tester the author has completed a model, in fact several models which have been sold to service men, and have proved extremely satisfactory in every respect. These units incorporate all the features found in numerous individual set testers—but not available in any one particular unit.

The testing unit has been conveniently assembled in a traveling case measuring 16 x 14½ inches outside dimensions and 7 inches high. The case is bound in leather and the corners bound with brass angles. The case itself is made of 3-ply veneer, which is both durable and light. After using this kit for nearly a year (four others are in other men's hands), I have found it perfect in performance every hour of the day. A close examination of the circuit will reveal many new and interesting features, seldom found in conventional set

testers. The circuit includes innovations from all makes of testers on the market, and several additions. Any service man making this tester will never regret the financial outlay. A few of the features incorporated are: tubes can be tested under actual operating conditions; 750 volt A.C. meter for testing power transformers, etc.; three other A.C. voltage ranges; self contained power plant; modulated oscillator for neutralizing, synchronizing and testing output; voltage and current tests of both plates in rectifier tubes; external connections for every piece of testing apparatus; tests and analyzes any set using any type or make of tube; handy carrying case; tube rejuvenator; an all range ohm-meter (the handiest thing a service man can have); compartments for adapters, tools and parts and many other special features.

The service men who wish to revamp their old test kits can substitute their own

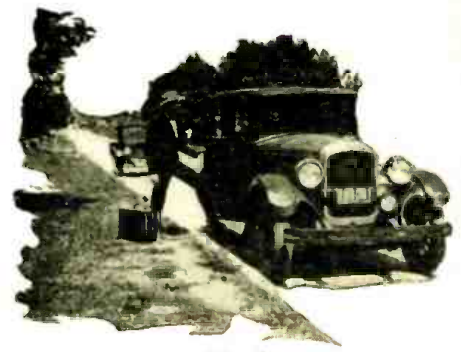

Fig. D

The author and his "Portable Testing Laboratory."

parts for those shown, but for the benefit of the men who wish to make a complete new tester, the parts required are listed according to sections.

### In the Set Analyzer Section

- 1—Weston 10-place bi-polar switch (1) wound with 192,000 ohm resistance or a separate 192,000 ohm resistor (R2);
- 1—Weston No. 301 0-8-200 D.C. voltmeter 1000-ohms-per-volt (2);
- 1—Jewell No. 74-A 0-3-15-150 three range A.C. voltmeter (3);
- 1—Jewell No. 54 0-25 D.C. milliammeter (4);
- 1—Jewell No. 54 0-1 D.C. milliammeter for ohm-meter (5);
- 1—5-point Carter Imp type inductance switch (6);
- 1—4-point Carter Imp type inductance switch (7);
- 4—SPDT miniature switches or Yaxley No. 730 two-circuit junior switches (8, 9, 10, 11);
- 3—DPDT miniature switches or Yaxley No. 760 2-way, 2-circuit junior switches (12, 13, 14);
- 1—4-prong CX type socket (15);
- 1—5-prong UY type socket (16);
- 1—Closed circuit jack (17);
- 1—Clarostat variable high resistance, power type, universal range (18);
- 1—Phone tip jack (19);
- 1—8000 ohm wire wound resistor for A.C. meter (R1);
- 1—600,000 ohm wire wound resistor for B range (R3);
- 1—72,000 ohm wire wound resistor (R4);
- 1—120,000 ohm wire wound resistor (R5);
- 10—Inches of No. 18 bell (annunciator) wire (R6);
- 2—Inches (about) of .015 manganin wire for the 1.14-ohm resistor (R7);
- 1—2.7-ohm wire wound resistor (R8).
- 1—7 x 15 Bakelite panel (an additional panel is needed for the upper half of the case).
- 19—Binding posts.

1—4½ volt "C" battery, Burgess No. 2370; The resistances should all be wire wound with slides so they can be cut down to the value needed.

The phone tip jack No. 19 arranges connection to the tops (control grids) of S-G. tubes. All meters should be checked with known standards when possible. If correct resistances are available the check can be dispensed with since the tolerance values employed in the manufacture of resistances are sufficiently close for radio service requirements.

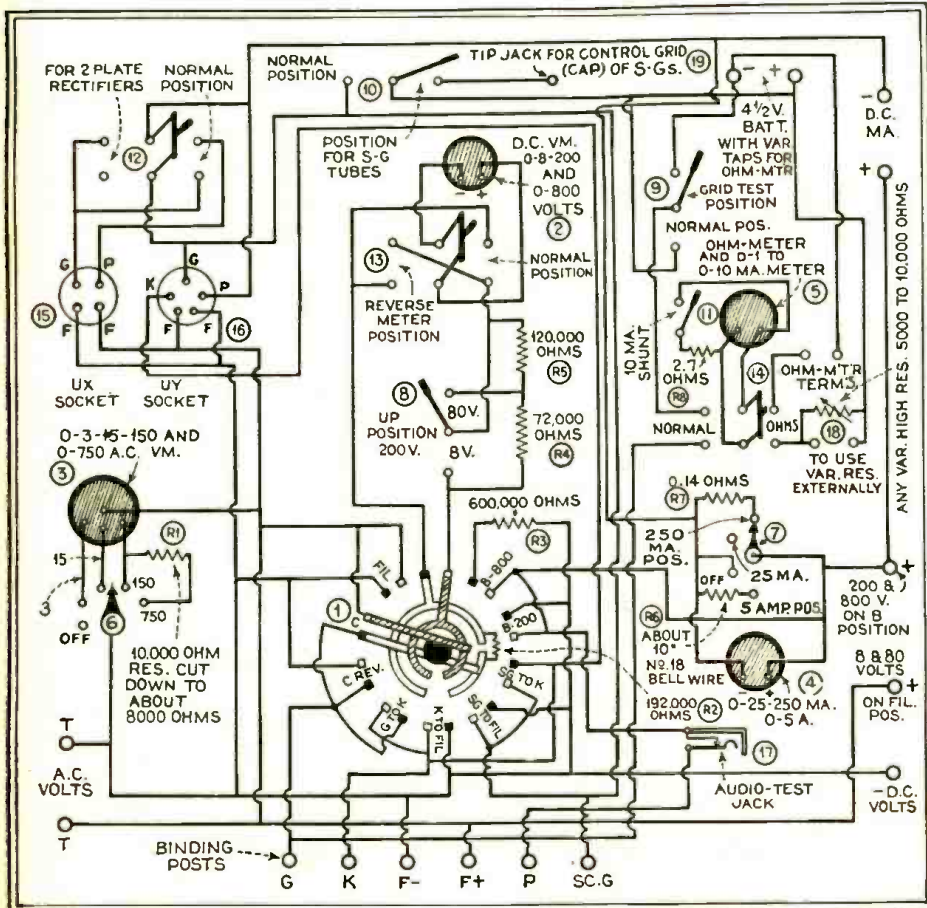

Fig. 1

Schematic circuit and connections of the Portable Radio Testing Laboratory.

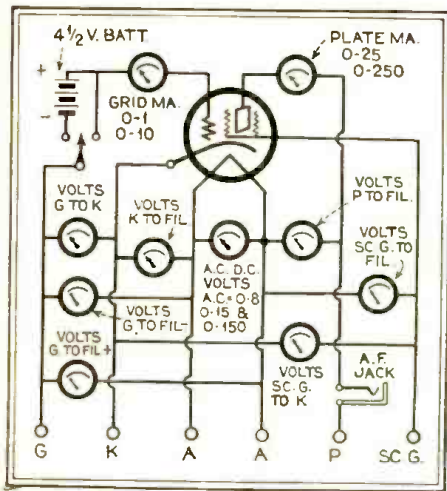

Fig. 3

Picturing the electrical positions the meters may be given when testing an A.C. screen-grid tube. However, most of these tests are possible on any tube.

The bi-polar switch can be purchased equipped with the proper 192,000 ohm resistance or the resistance can be added to it externally.

The track provided for the resistance is in the wrong place in the completed switches and must be soldered and the split in the track must be cut at the place shown in Fig. 1. This can easily be arranged with a hack saw blade and the end of the resistance soldered in again at the new cut, as shown in diagram. Six binding posts (at the bottom of the diagram) provide connection to the five wire cable. The adapter plug is connected to this. Full directions for making this cable adapter are evident upon examination of the picture diagram.

For screen grid connections (the sixth binding post) an outside piece of wire is used with clips on it and the length is the same as the five-wire cable adapter.

The bi-polar switch dial can be calibrated to read in the nine different steps as follows: filament; "C" batt; "C"-A rev.; "G" to "K"; "K" to filament, screen to filament, screen to "K"; "B" 200 scale, "B" 800 scale. "C" is the grid connection, "K" is the cathode terminal and "B" the plate terminal. Fil. designates the filament.

To the 0-8-15-150 scale of the AC voltmeter must be added a 750 volt scale. This is done with red ink or black India ink. This scale as well as the others on the other meters can be checked for accuracy by using the next lower scale. Connect the 150 volt scale to the 110 AC line and read potential in volts and then switch to the 750 volt scale and calibrate. With the 700 volt resistance in series, multiply the 150 volt scale by 5. "C" battery, "A" reversed connects the negative of the "C" voltmeter to the other side of the "A" battery leads. Be sure to use a 1000-ohm-per-volt meter as the DC voltmeter in order to get correct readings of the "C" and "B" voltages. The other meters can be of any type as long as they will fit in the proper places.

External readings obtainable with set analyzer binding posts:

0 to 3 volts AC; 0 to 15 volts AC; 0 to 150 volts AC; 0 to 750 volts AC; 0 to 8 volts DC; 0 to 80 volts DC; 0 to 200 volts DC; 0 to 800 volts DC; 0 to 1 milliamper DC; 0 to 10 milliamper DC; 0 to 25 milliam-

peres DC; 0 to 250 milliamperes DC; 0 to 5 amperes DC; and ohm-meter readings mentioned later.

Testing Tubes Under Load

When testing tubes the average characteristics of the tube under test must be known. It is a good idea to memorize them, or carry a sheet pasted on tester cover giving the dope. Couple the five wire cable to the five binding posts on the lower edge of tester panel. (If screen grid tubes are being tested, run a separate wire from the control grid clip in the set to the regular grid binding post on tester marked G. The grid wire from the socket of set in this case is the screen grid and goes to the screen binding post.) A color code for the five wire cable speeds connection of it. The grid wire is green. The plate wire is purple. The cath. is or, as sometimes spelled, Kathode is K and also C so a cream colored wire is used. The two filaments can be marked the same; black for both being convenient. Adapter is attached to the end of the cable. The end of the cable as shown, is the old 5 prong tube base of a '27 tube. When testing '27s no adapter is needed. When testing 4 prong sockets a 5 prong-to-4 prong adapter is used. If WD tubes are to be tested, a WD adapter is attached to the combination 5-4 adapter. (The adapters were secured from the Alden Mfg. Co.)

The next step is to place the tube in the proper socket of tester. The set is turned on and the plate current is noted on milliammeter employing the 25 MA scale, (4) arranged by placing the switch (7) in the 25 MA position. All other switches are in normal position or "off." The plate current consumption of the tube is noted, prefer-

ably on such sheets as the manufacturers of set analyzers distribute for 25c. Such sheets are of great utility. Switch No. 9 is then adjusted for the grid test and again the plate current is noted. The second reading is subtracted from the first reading and the greater the remainder the better the tube as an amplifier, detector and oscillator. When testing rectifiers determine plate current for each plate by manipulating switch 12 to rectifier setting. This applies to the '80 tube.

When testing screen-grid tubes switch No. 10 is kept in the SG (screen-grid) position and a short wire is run from the phone tip jack on the panel to the top of tube, (the control grid). Check the 4 1/2 volt battery once a week to see if voltage is below normal. When it is it should be discarded.

(The location of each tube in a receiver will be found in the new R.C.A. "Radiotron Data Book.")

Set Testing

The set tester is arranged as described above with the 5 lead cable connected to it and cable plug inserted in first RF socket. Before placing the removed tube into the tester socket the set should be turned "on" and the filament voltage of the set determined by swinging the bi-polar switch to filament position. Switches 8 and 13 are set to the correct voltage and polarity positions. This adjustment will afford the filament voltage without load. Make a record of the voltage value; then the bi-polar switch is twisted around to either the B200 or B800 position. (Switches 13 and 8 to remain as before.) We now record the plate voltage without load. After these tests are

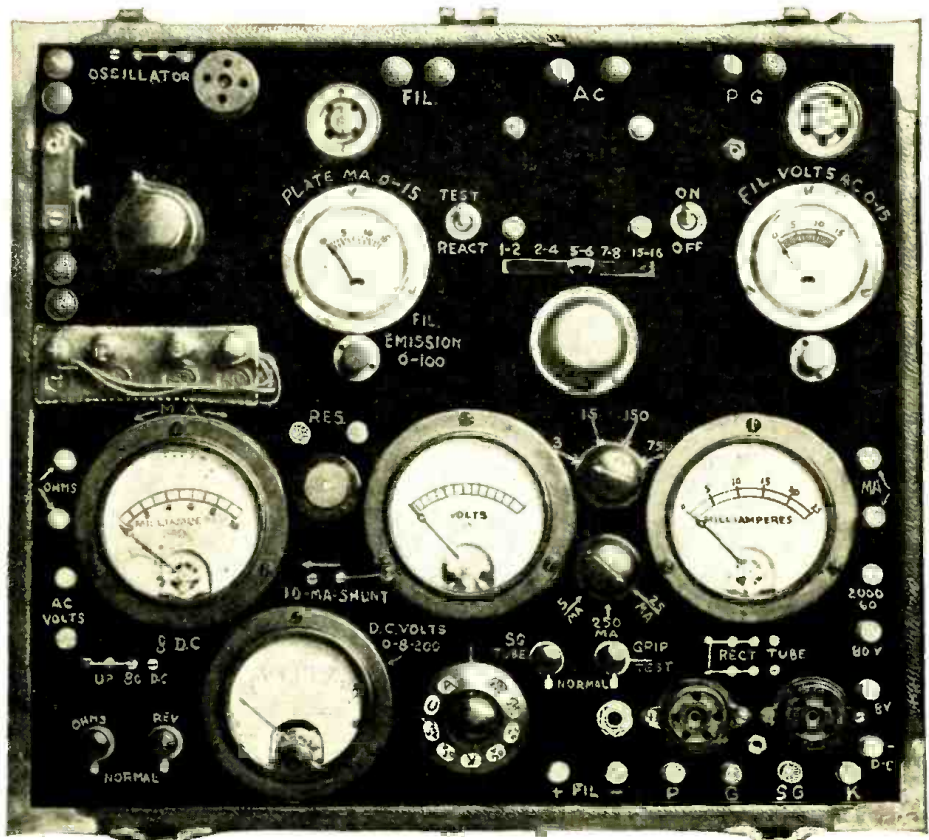

Fig. A

Appearance of the completed panel of the Portable Tester. All voltmeters can be reversed. Line dividing upper and lower panels does not show.

completed the tube is inserted in the proper socket and the same two readings are again taken, this time, however, under load. After

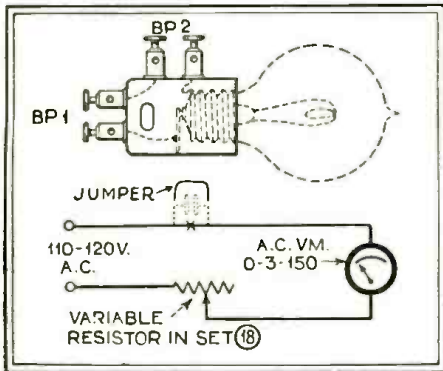

Fig. 7 (top) Fig. 8 (bottom)

Above: Connections for continuity test. Line connects to BP1 and test prods to BP2. Below: Connections of the capacity meter. Use VM on 3-volt terminals but read on 150-volt scale, as follows: 0.5 mf., 48 to 52; 1.0 mf., 78 to 80; 1.5 mf., 99 to 101; 2 mf., 115; 2.5 mf., 125; 3 mf., 132; 3.5 mf., 138; 4 mf., 145; 4.5 mf., 148; 5 mf., 152.

the new values are recorded the test of this particular part of the set is completed. We then progress to the next RF stage and repeat each test—until all the tubes and circuits have been tested. Since all voltage values have been recorded, analysis should show the location of the defective system. When testing AC sets read the filament voltage on the AC meter (3). (The bi-polar switch remains at "off" position.) Switch 6 in the case of AC sets is placed at either 3 or 15 volts depending upon the filament voltage of the set under test.

The power supply transformers are likewise tested with this meter. The AC voltmeter has a 750 volt scale calibrated for that purpose or you can use the 150 volt scale, with the series-multiplier multiplying

Fig. 16

At the right is reproduced one of the analysis sheets referred to in the text. It has been filled in, as an example, to show how test data on the All-American Mohawk were recorded. Such a sheet should be preserved, and will be a valuable record to have, in case of a second call.

**RADIO SET ANALYSIS**

OWNER: Geo. C. Miller      DATE: Oct. 15, 1929  
 ADDRESS: 2110—CUI AVENUE  
 NAME OF SET: All-American Mohawk      Model 90 Lyric

TUBE NO. ORDER	TYPE	POSITION OF TUBE	RESISTANCE PLUG IN SOCKET OF SET					TUBE IN TESTER					
			1ST	2ND	3RD	4TH	5TH	1ST	2ND	3RD	4TH	5TH	
1	2-7	1st R F	2.4	120	2.4	128	7	7	5.8	8.6	2.7		
2	"	2nd R F	"	"	"	"	7	7	"	"	"		
3	"	3rd R F	"	"	"	"	7	7	"	"	"		
4	"	4th R F	"	"	"	"	7	7	"	"	"		
5	"	Detector	84	"	"	16	0	0	.7	.7			
6	"	1st A F	94	"	"	24	1.6	2.5	1	1.2			
7	"	2nd A F	128	"	"	106	1.5	7	3.6	4.7	1.1		
8	245	P.P.	2.55	256	2.45	232	.45	"	23	26	3.		
9	"	P.P.	"	"	"	"	"	"	"	"	"		
10	290	Amplifier	4.3	"	4.9	"	"	"	80	"	"		

LAMP VOLTAGE: 111      SET OF: 95-115      VOLUME CONTROL POSITION: Full

SUGGESTIONS OF CHECKS MADE:      Set O K

GEO. C. MILLER—RADIO SERVICE  
P.O. Box 508—JACOBS, WASH.

readings by 5, to get the correct reading. The 1 and 10 MA readings on meter 5 need not be specially calibrated. Simply remember which scale you are using and multiply the meter scale accordingly. The 25 MA meter 4 has five divisions already marked upon it and these are used for the 5 ampere reading when testing battery charges and other high current values.

stage and the set is not equipped with a first stage jack plug speaker into the tester jack. If the signal can be heard in the detector plate circuit and not in the first AF plate circuit, the trouble is between the detector and the first audio output.

**Testing Condensers**

Fig. 8 shows the circuit for testing the condensers in the power pack of the sets. Since capacity values are seldom designated a simple method of testing is a handy addition. To test place a wire from the binding post of the variable resistance 18 to the AC meter and another lead to the AC 110 volts with the condenser under test in series as shown. If you are using a clorostat or carbon variable resistance the test should be made quickly as the current will increase after the resistance heats. A wire wound variable resistance capable of carrying about 100 MA will stay constant at any current value within reason. To find capacity connect a condenser as shown in Fig. 8. Then place a short wire across condenser terminals so as to short circuit them. Apply the 110 volts, AC to terminals marked and adjust variable resistance till the meter

(Continued on page 336)

**Next Month**

A NEW series of articles which will run for an entire year, entitled **Sound Projection Engineering**. This series will be written by a number of experts in this line and will do much to give our readers the latest technical information on this new branch of radio, now being used in practically all motion-picture theaters throughout the world. —EDITOR.

The audio test jack 17 is used when hunting trouble in the audio frequency end of the set. If no sound comes out of the last

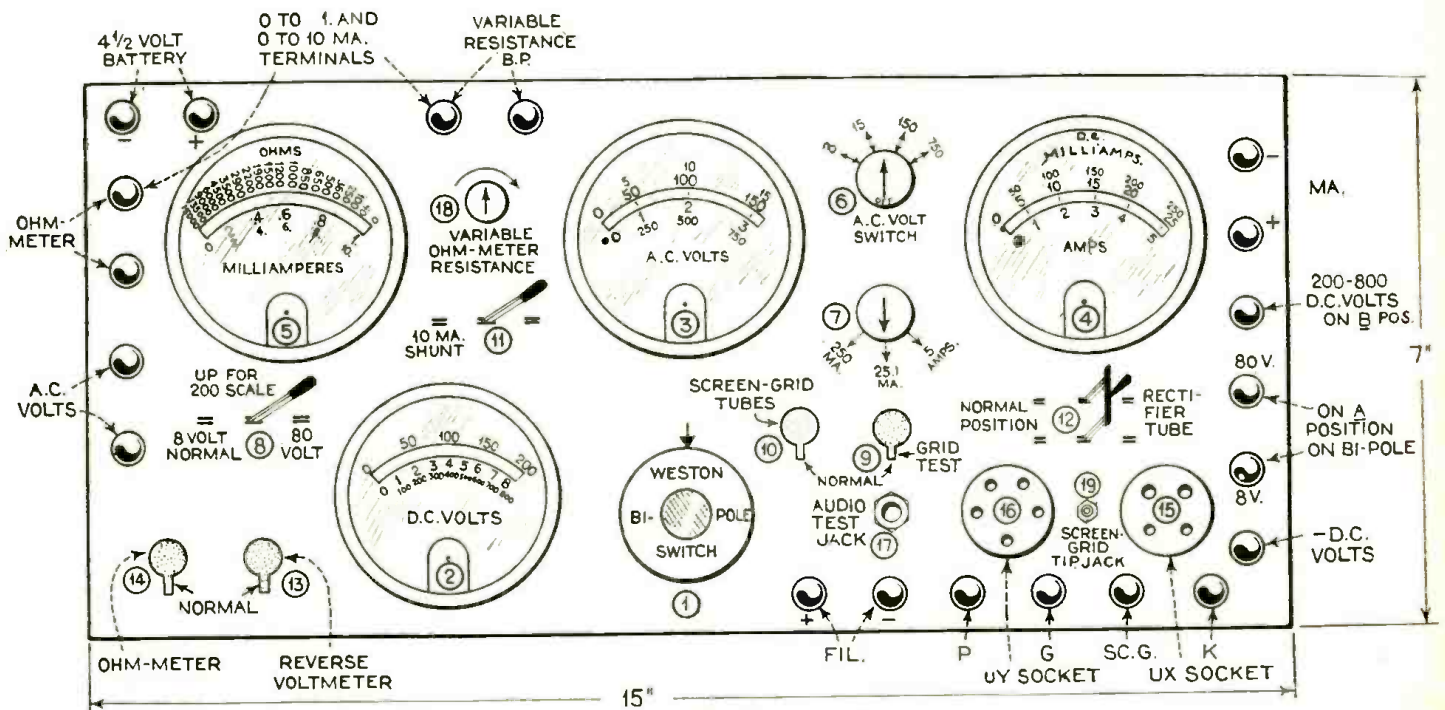

Fig. 10

Parts layout of the Portable Radio Testing Laboratory—corresponding with Fig. 1.

# Causes and Cure of Radio Interference

*Interference is the most formidable enemy of the Service Man, because the hardest to combat. Mr. Bristow analyzes the subject systematically, describing in detail the remedies for the types of interference which may be overcome or mitigated.*

By F. R. BRISTOW

Supervisor, Home Study Division, Radio Institute of America

THE term "interference," in the broadcast radio sense of the word, means that sounds emerge from the reproducer which are not a part of the desired signal, but form a disturbing background. They are usually unintelligible sounds which may be described as crackling, sputtering, squealing, or queer whirring and buzzing noises. The cause of many of these disturbing sounds that detract from the radio program is readily understood; while that of others is recognized, usually, only by the service man who has actually become experienced in this phase of the work.

The causes of radio interference may be classified under the six headings which follow:

- (1) Broadcast transmitters radiating energy on the same, or nearly the same, wavelength;
- (2) Nearby powerful broadcast stations;
- (3) A neighboring receiver which, in an oscillating condition, will act as a miniature transmitter;

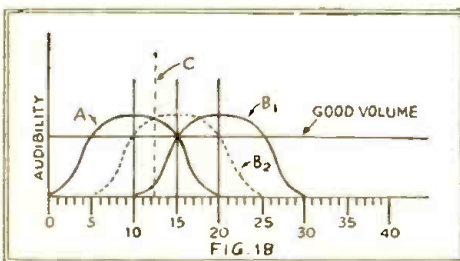

With one tuned circuit, two stations fully ten kilocycles apart interfere; a lessened separation, as at B2, causes high continuous whistles.

- (4) Electrical atmospheric disturbances arising in space, and commonly known as "atmospherics," or "static";
- (5) Faulty parts of a receiver, at times, causing disturbing noises;
- (6) Lastly, interference which originates from commercial electrical machines, power lines, trolley cars, elevated systems, subways, home electrical appliances, and electrical apparatus used in the professional fields, such as X-ray and violet-ray equipment.

### Whistling, Pig-Squeals, etc.

Interference of the nature outlined under No. 1 may be due to transmission problems or to lack of selectivity in the receiver. By "transmission problems" are meant the possible faults in frequency-control devices of transmitting equipment, or that two stations are operating on or about the same frequency at the same time, or on frequencies not separated by at least ten kilocycles. The effect of this is shown in Fig. 1B.

Conditions of the latter kind, however, are rapidly disappearing because of the cooperative work of the Radio Commission and the officials of broadcast stations. (Reallocation of wavelengths, and maintenance of a more active watch on frequency-control devices, are major cures.)

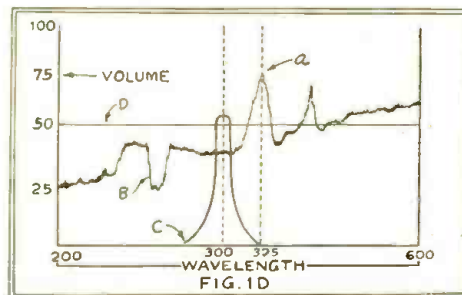

Selectivity may be advanced to the point of distortion; static is, however, thus excluded except on the narrow waveband the circuit passes. (A, static; B, surge; C, program; D, good volume.)

A shrill whistle which forms a background to the program being received may be caused by broadcast stations within ten kilocycles of the desired station. These two different radio-frequency currents pass simultaneously through the receiving circuit, producing an entirely new frequency which is audible. The production of this third frequency, or *beat note*, when one frequency is superimposed upon another, is called *heterodyning*. This phenomenon explains the meaning of the expression, "the heterodyning of two stations."

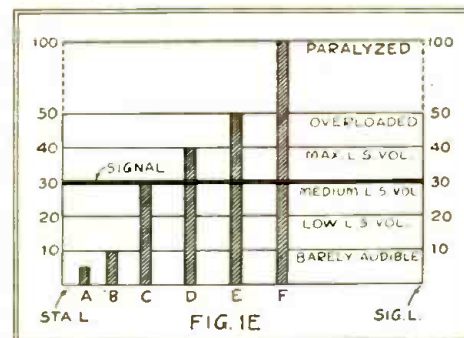

Taking the "signal level" as 30, and "static level" as lettered, interference has the effect shown; a powerful local signal also may paralyze the first R.F. tube.

From this analysis, one realizes that the service man is not expected to correct troubles of this nature. These difficulties must be removed by the engineers of the stations at fault, though the selective receiver, confining its action to a ten-kilocycle tuning band, plays an important part in eliminating interference coming under this classification.

### When Sensitivity Is Not Desirable

At times, the sensitivity of a receiver affects its selectivity. Hence, a receiver of very sensitive design will usually make an interfering signal audible under conditions where a less sensitive receiver will not reproduce the interference. The procedure to adopt, when interference is experienced with an extremely sensitive receiver, is to reduce the sensitivity of the receiver by adjustment of the controls provided on the particular set.

With a selective circuit tuned to a predetermined frequency, any other frequency above or below the specified frequency will find reactive forces at work which will cause a greater attenuation; that is, dwindling or dying out of currents at frequencies other than those which the circuit is tuned to pass. (See Figs. 1D and 1E.) It is upon this principle, among others, that the radio broadcast receiver is designed.

A receiving circuit, however, which incorporates only one tuned circuit will prove

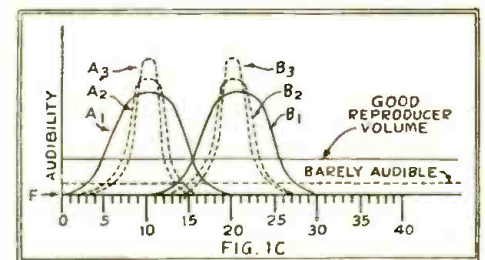

With the same station separation as in Fig. 1B, the greater selectivity obtained from additional tuned R.F. circuits B2 and B3 permits louder reproduction with less interference.

inadequate in providing fine selectivity because of present-day interference problems; ten-kilocycle selection is the necessity for clear reception.

### Selectivity in Interference Elimination

This is obtained by coupling together a series of "tuned radio-frequency stages." By this system the desired frequency is selected, each tube amplifying this frequency only; while current of the undesired frequency is materially weakened as it passes through each successive tuned stage (Fig. 1C).

Receivers used for radio broadcast reception may be classified as follows:

- (1) Those which utilize one stage of tuned radio frequency, and variable regeneration.
- (2) Those which utilize three stages of tuned radio frequency without effective balancing of coupling between the radio-frequency stages; each stage, however, being heavily damped by what

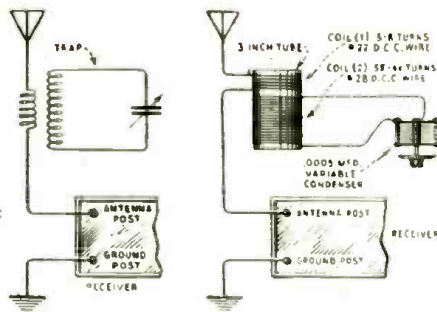

Fig. 1

The "absorption" type of wavetraps; to eliminate powerful local interference it may be necessary to increase, to 15 or 18, the number of turns in coil 1.

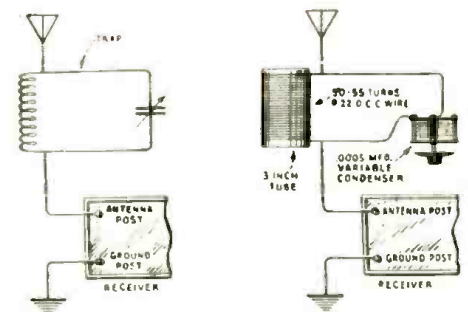

Fig. 2

The "rejector" wavetraps is extremely effective in reducing signal interference; but it also causes a reduction in the strength of desired signals.

lar frequency to the exclusion of others, especially when it is located close to a powerful transmitter. When this is the case, a device known as a "wavetraps" may be employed to overcome the difficulty.

About Wavetraps

A wavetraps is a device designed to reduce or eliminate radio interference when this is caused by stations other than the one desired. There are two principal types; one is known as the "absorption" ("acceptor") type, and the other is the "rejector."

A diagram of the former appears in Fig. 1. As shown, there are two coils wound in a three-inch form in such a manner that inductive coupling is provided between the two windings. The small coil consists of from 5 to 8 turns of No. 22 D.C.C. wire

interfering signal and the position of the tuning controls of the receiver. To obtain close coupling, wind coil 1 close to coil 2, thus decreasing the distance between them. This will materially aid in eliminating the interfering signal; but it usually has a considerable effect upon the position of the tuning controls of the receiver.

To effect loose coupling, wind coils 1 and 2 with an open space between the two windings.

The correct spacing between the two coils, for satisfactory elimination of the interfering signal with the least change in the receiver controls from their normal tuning position, is learned by experiment and, when once found, should be made permanent.

To use the wavetraps, set its condenser at zero, tune the receiver until the interfering signal is received with maximum volume; then rotate the trap condenser until the undesired signal is reduced to minimum strength. Carefully readjust the receiver (Continued on page 311)

is termed the "grid-suppressor" method, which prevents oscillation between the R.F. circuits.

- (3) Those which utilize three radio-frequency stages without the grid-damping resistors, but effect more or less complete balancing of interstage coupling between the radio-frequency stages.
- (4) Superheterodyne receivers.

Receivers in the first classification are more selective than those consisting of a detector and audio-frequency amplification only. Class 2 has a higher degree of selectivity than class 1; and greater selectivity may be attained with class 3 or 4 than either of the preceding.

Individual receivers, however, may vary in the degree of selectivity they are supposed to possess, regardless of their design, and especially when located in close proximity to a powerful broadcast station. Those most subject to interference because of their location to a nearby powerful broadcast transmitter are of class 1 or others not described here (such as the "single-circuit" type, and some home-constructed sets). The majority of receivers outlined under 2, 3 and 4 are factory products, and little or no trouble will be experienced with them.

Occasionally, however, any receiver will be lacking in capability to select a particu-

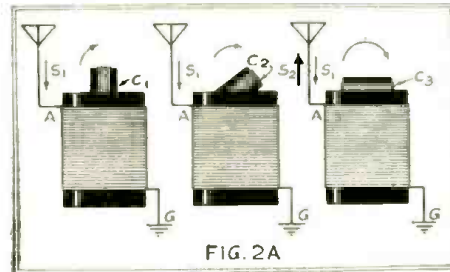

FIG. 2A

When the rotatable (ticker) coil in the detector's plate circuit is at C1, reception is normal; at C2, it gives regeneration and sensitivity increases up to a "spill over." At C3 it makes the circuit oscillate and radiate a disturbing signal S2.

closely wound; this is connected directly in the antenna as shown.

The large coil is wound with 55 to 60 turns of No. 28 D.C.C.; a .0005-mf. variable condenser is connected across this coil.

The degree of coupling between these windings affects both the elimination of the



When noises start in your radio, out of the door your friends will go.



# Men Who Made Radio—Reginald A. Fessenden

THE FOURTH OF A SERIES

**I**N the ranks of the scientists and inventors who have made radio what it is today, it is hard to classify the subject of this brief sketch as belonging more to one division than to the other. In both roles, he has been one of the most striking figures; and his versatility, be it said, has extended throughout many fields. There is little which he has touched, in the field of knowledge, to which he has not made distinct contributions. Yet, pre-eminent among Professor Fessenden's achievements are the developments which he made in the art of radio telephony—that department of radio most interesting for the layman, because it includes broadcasting.

Reginald A. Fessenden was born in Milton, Province of Quebec, Canada, although of Colonial American ancestry. While yet a very young man, he became associated with Edison, as an electrical engineer, and later as chief chemist. He later worked with the Westinghouse Company; and in 1893 became professor of electrical engineering in the Western University of Pennsylvania, at Pittsburgh. Here, as early as 1895, he began experimental work with radio waves (or "Hertzian," as they were then known). In 1899 he there made radiotelegraph demonstrations with the idea of facilitating the work of the Weather Bu-

reau. He soon became associated with that organization; and later the technical guide of the National Electric Signaling Co., one



of the rival organizations which were then pushing the development of "wireless telegraphy."

But Dr. Fessenden, a master of the dynamics of sound—among many other things—saw possibilities in "wireless" of more than telegraphy. The Hertzian waves used in spark telegraphy rose and fell in "damped" oscillation; Fessenden conceived the possibility of generating undamped or "continuous" waves, and imposing upon them the modulations of speech. In 1901 he accomplished this feat, and his was the first human voice to be borne into space on a radio "carrier." To this success, he added that of the rectifying electrolytic detector, the successor of the coherer and the precursor of the crystal and the tube. So, also, Fessenden conceived and patented the idea of the radio-frequency alternator. He worked in this field for years, increasing more and more the world's knowledge of radio, and in 1909 added the rotary spark-gap to his previous inventions, thereby extending the range of "wireless" signals. Among his earlier suggestions we find, as well, the use of the principle of heterodyning; which was compelled, however, to wait the development of the tube oscillating circuit for its perfected application. In 1909 Fessenden successfully demonstrated radio telephone operation between Brant Rock, Massachusetts, and Washington.

(Continued on page 336)

## Attention: Radio Service Men

**R**ADIO-CRAFT is compiling an international list of names of qualified service men throughout the United States and Canada, as well as in foreign countries.

This list, which RADIO-CRAFT is trying to make the most complete one in the world, will be a connecting link between the radio manufacturer and the radio service man.

RADIO-CRAFT is continuously being solicited by radio manufacturers for the names of competent service men; and it is for this purpose only that this list is being compiled. There is no charge for this service to either radio service men or radio manufacturers.

We are hereby asking every reader of RADIO-CRAFT who is a professional service man to fill out the blank printed on this page or (if he prefers not to cut the page of this magazine) to put the same information on his letterhead or that of his firm, and send it in to RADIO-CRAFT. The data thus obtained will be arranged in systematic form and will constitute an official list of radio service men, throughout the United States and foreign countries, available to radio manufacturers. This list makes possible increased cooperation for the benefit of the industry and all concerned in the betterment of the radio trade.

### NATIONAL LIST OF SERVICE MEN.

c/o RADIO-CRAFT, 98 Park Place, New York, N. Y.

Please enter the undersigned in the files of your National List of Radio Service Men. My qualifications are as set forth below:

Name (please print) .....

Address ..... (City) ..... (State) .....

Firm Name and Address .....

*(If in business for self, please so state)*

Age ..... Years' Experience in Radio Construction? .....

Years in Professional Servicing? .....

Have You Agency for Commercial Sets? ..... (What Makes?) .....

What Tubes Do You Recommend? .....

Custom Builder ..... (What Specialties?) .....

Study Courses Taken in Radio Work from Following Institutions .....

Specialized in Servicing Following Makes .....

What Testing Equipment Do You Own? .....

What Other Trades or Professions? .....

Educational and Other Qualifications? .....

Comments .....

(JAN.) (Signed) .....

# SHORT WAVE CRAFT

## The Short-Wave Receiver As a Money-Maker

*With the development of an inexpensive A.C. set, the professional radio man can easily sell receivers assembled from manufacturers' kits*

By JOHN GELOSO

*Chief Engineer, Pilot Radio & Tube Corporation*

**T**HE custom radio builder, or the service man who wishes to do a little profitable set building on the side, can add materially to his income by assembling short-wave receivers from manufacturers' kits and selling them to the many people whose interest in the short waves has been aroused by the numerous published reports describing trans-oceanic "DX" accomplished with simple short-wave sets. Until recently this potential market could not be touched, because all available short-wave sets required the use of storage "A" batteries and a flock of dry "B" batteries; and in these days of all-electric receivers few will ever consider a battery outfit.

Now, however, there is available on the open market a kit of parts for a completely A.C.-operated short-wave set that really works, and works well. The "A.C. Super-Wasp" is a modification of the Pilot battery-model "Super-Wasp," which was described in detail in the the July number of *RADIO-CRAFT* (the same coils may be used); and the kit is so cheap that the professional radio man can assemble it, install it complete with power pack, and make more than \$25 profit if he charges \$75 for the whole



*The attractive appearance of the "A.C. Super-Wasp" in its metal-paneled cabinet, is shown above. The jack permits the use of phones, which are desirable for tuning, as well as a loud speaker.*

job. The kit itself retails for less than \$35, and the power pack for \$16.50. If you happen to have an old 171A pack around (and if you haven't there are hundreds that can be picked up for a song), you can charge even less, and still make a good profit. Many service men and set builders have

engaged in this business, and are literally "cleaning up."

### Finding the Prospect

The prospective customer who is most easy to "sell" is the ex-radio fan who stopped building his own broadcast receivers two or three years ago, because the manufactured sets were so much cheaper and better. Reading the radio section of the newspapers, and perhaps occasionally buying a copy of a radio magazine, he feels his old interest reawakened by the short-wave news, and he would like to get back in the game. However, he does not want to buy batteries; and his wife won't let him fuss around the kitchen any more; and he hasn't time to assemble a short-wave kit himself. You often encounter such an individual puttering around radio stores; and you meet him in the course of your regular work.

The best part of this short-wave business is that one set sells a dozen more. Getting Europe, Canada, Central America and Australia with a short-wave receiver is really not difficult at all; and the purchaser boasts about his "DX" to every friend he meets. You know the old competitive spirit. "If Jones can hear Holland on a \$35 set, I can too"—and another sale is made.

The "A.C. Super-Wasp" kit includes everything necessary for the receiver, down to the last washer and soldering lug. For the benefit of those who missed the description of the battery model in July *RADIO-CRAFT*, a detailed description of the features of the circuit is given herewith.

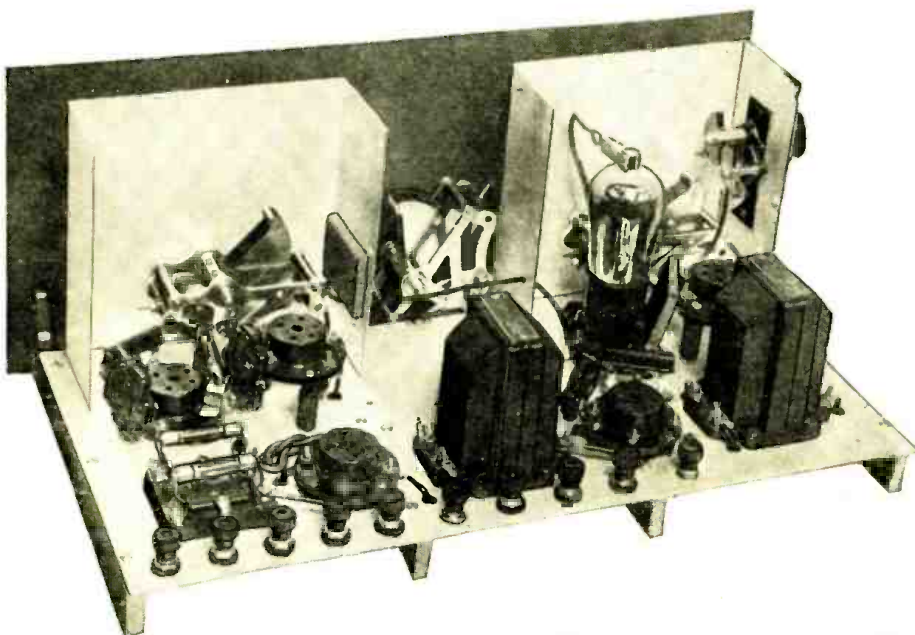

*The chassis of the "A.C. Super-Wasp" without power pack. The manner in which the special shields are separated into halves facilitates assembly. The difference in layout from the D.C. model is slight, but incorporates some advantages. Additional by-passing is required by the use of biasing filament-return resistors; and special chokes are used in the plate and screen-grid leads of the 24 tube.*

The receiver circuit shows plainly the precautions taken, to make possible high-quality reproduction of short-wave broadcasts—the newest idea in radio.

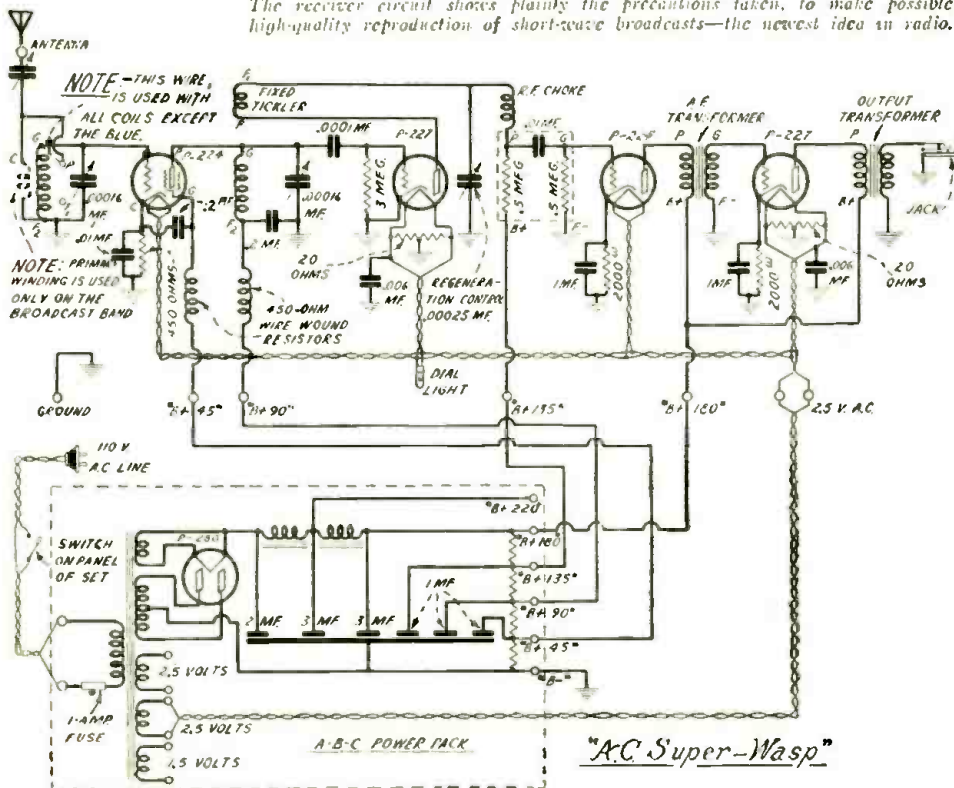

Eliminating the Hum

The first question every technical man asks about the "A.C. Super-Wasp" is, "How much does it hum?"

The answer is that the set does produce a very weak "residual" 60-cycle hum, which is just about noticeable in a pair of sensitive phones. It is so slight that you don't even know it's there after you've listened for a few minutes. More important, there is no hum on the point of regeneration. This was the difficult nut to crack; with any ordinary circuit and any ordinary '27 detector, everything is quiet and lovely while the detector is *not* regenerating. With the circuit anywhere near oscillation, however, it breaks out into a roar that sounds like Niagara Falls. With the hook-up shown, and with the specially-developed Pilot 227 tube, the set slides into oscillation as gently as any battery-operated outfit.

This tube has a *hairpin filament* inside the cathode, instead of the usual straight wire. A filament of this type does not tend to give the plate current of the tube a 60-cycle modulation, which will ruin reception. Adequate *by-passing* in the filament circuits prevents the formation of little local oscillating circuits (the combination of the inductance of the center-tapped resistor and the filament-to-heater capacity) and chases off the scale the many little hums that have definite wavelengths.

The leads to the screen-grid of the '24 and to its plate are protected by 450-ohm circular wire-wound resistances, which act rather as R.F. chokes than as mere D.C. resistances. Their actual ohmic resistance is a mere trifle, compared to the overall resistance of the circuits of which they are part; but their *inductance* is appreciable on the wavelengths below 70 meters, where their choking effect is desired.

Correct Voltages

The accompanying schematic diagram shows the full hook-up of the "A.C. Super-Wasp," with its power pack. The connections are all simple, and will be readily understood by the service man or set builder. It should be remarked that, because of the light current drain of

(Continued on page 311)

Design of the Circuit

The set uses four tubes, one '24 screen grid and three '27's. The Pilot 227 has been developed especially for use in the detector socket of a short-wave receiver; any ordinary '27 develops a terrible roar on the critical point of regeneration, just the point at which all short-wave sets are always operated. The screen-grid tube is used as an R.F. amplifier, with a *tuned* input circuit; this '24 feeds into the regenerative detector, which is followed by one resistance-coupled audio stage and one transformer-coupled stage, with an output transformer. A '27 is used in the last stage also to keep down the hum. A '71 or a '45 is out of the question, for both have raw-A.C. filaments: they are quiet enough on a loud speaker, but hopeless with a pair of headphones. The tone quality with a '27 output tube is surprisingly good; with 180 volts on the

plate it is as good as a '12A and not very much poorer than a '71A.

Two plug-in coils at a time are used to cover any one of five wave bands; ten coils being supplied altogether. The range is from 14 to 500 meters, taking in practically everything in the world worth hearing. The ability of the set to cover the regular broadcast band is very important; for it keeps the outfit sold in locations where short-wave reception is not all it might be.

The components of the radio-frequency and detector stages, respectively, are enclosed within aluminum cans, which shield them effectively. A metal front panel and a metal sub-panel are used; the front panel acting as an additional shield against the detuning effect of the operator's body. There are absolutely no such hand-capacity effects, even on 14 meters. All parts are furnished accurately drilled; so that you can assemble and wire the whole set in four hours.

LISTENING IN ON AVIATION WEATHER REPORTS

WHILE the field outside the broadcast band, for most listeners who do not understand code, has been practically limited to short waves, an interesting opportunity is developing higher up.

The U. S. Weather Bureau has just belted the country with radiophone stations along the transcontinental air routes, to give information to airplanes concerning storms, fog, etc. Spaced from 100 to 150 miles apart, they insure that a pilot need not be out of their range at any time. They operate between 857 and 1052 meters.

A coil like that illustrated at the right might be used by an ingenious short-wave experimenter; although with a small condenser an enormous number of turns would be needed (from 300 up). Experiment would be necessary with the particular tuning condenser and coil form used; and the tuning range would be small.

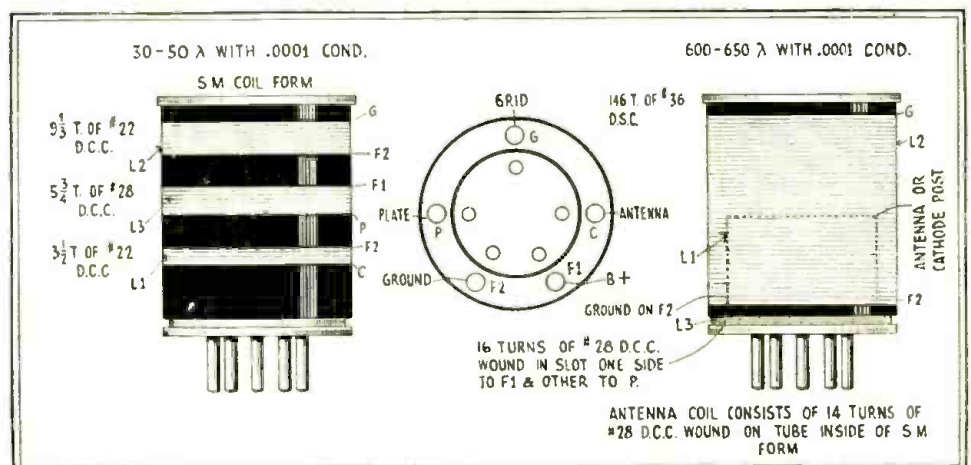

Those of our readers who have inquired the coil specifications of the long- and short-wave receiver used by K1K, as described by Mr. Brunner in our November issue, will find them here. The larger coil adapts a short-wave set to ship's calling wave. The coil form is 2 1/4 inches in diameter.

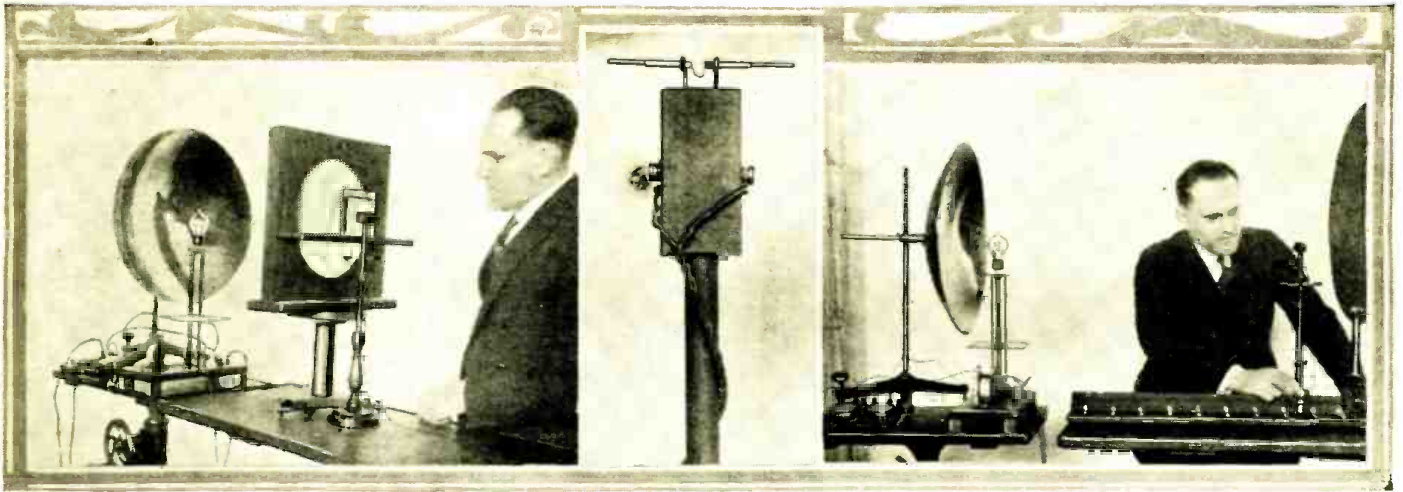

**Fig. 1**  
The tube is emitting ultra-short waves which are reflected, just like light, through the lens in the center, to a glass of water, and thence to the little receiver.

**Fig. 5**  
A close-up of the antenna and detector of the 14-cm. radio receiver.

**Fig. 2**  
Here the radio waves focused by the mirror are reflected by the metal disc at the right. The result is an interference pattern of R.F. signal voltages.

## Six-Inch Radio Waves

They are produced by a "tuned-tube" and picked up by a crystal detector. Parabolic mirrors are used. Experiments are described.

By **ERNST GERHARD**  
Erlangen, Germany

AT a meeting of the German "Heinrich Hertz-Gesellschaft" (Heinrich Hertz Society), which took place a short time ago, Dr. K. Kohl, of the University of Erlangen, showed some very interesting experiments with undamped "monochromatic" waves 14 centimeters in length. The well-known Hertz experiments were presented with the aid of a modern auxiliary, the electron tube, together with many newer experiments.

Some years ago Barkhausen and Kurz, while making investigations of the vacuum in electron tubes, discovered the presence of ultra-short waves of less than one meter wavelength. It appeared that, to produce these vibrations, the grid of the tube must be given a high positive voltage and the anode (plate) a relatively slight negative voltage. According to the theories of Barkhausen and Kurz, it was the result of purely electronic vibrations, whose frequency was determined only by the operative data of the tube and was not dependent on any internal or external oscillation circuit. Dr. Kohl, however, was able to demonstrate by new researches that, to excite these oscillations, there must always be present an oscil-

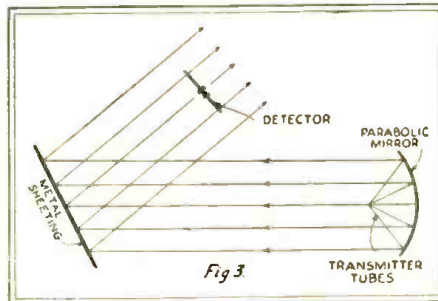

The experiment of Fig. 2 (upper right) is shown here schematically. The metal of the mirror and the screen reflects the 14-cm. waves sharply.

latory circuit to determine the frequency. Especially by proper reduction of the elements determining the frequency, Kohl was successful, under normal operating conditions, in producing undamped waves with a fundamental length as short as 8 centimeters (3.2 inches) and to demonstrate their radiation into free space!

In the experiments described below, the transmitter was a tube constructed by the firm of Tekade (Nuremberg, Germany) according to Dr. Kohl's directions, and containing in the glass bulb as the oscillatory element a small spiral grid, which is excited at its natural frequency and radiates a constant wave 14 centimeters (5.6 inches) in length. A specially-made receiver, in the form of a rod half as long as the wavelength, was used; the detecting element (crystal) being set in the middle. (See Fig. 5.) The oscillation was modulated at audio frequency in the transmitter by a special process: so that the reception could be heard in the loud speaker, after two stages of audio-frequency amplification.

### Radiation Effects

The experiments described below correspond to well-known experiments with

"monochromatic" (single-wavelength) light. The practical demonstration of such optical experiments becomes possible if the wavelength of the electric waves is comparable with the linear dimensions of the experimental apparatus. With a 14-centimeter wavelength this requirement is completely satisfied.

First, presence of free radiation was proved directly with the detector in the vicinity of the sending tube. It was shown that the radiation was polarized in a plane and in this case, the direction of the electric field was horizontal. If the axis of the receiver rod was turned until it was horizontal and parallel to the grid spiral of the transmitting tube, the sound received was a maximum. Turning the detector 90 degrees, in a horizontal or vertical plane, caused almost complete disappearance of reception.

The influence of a straight "resonator" on the transmitter or receiver was shown by the following experiment:

A small copper rod half as long as the wavelength (i.e., 7 centimeters—2.8 inches) was placed behind the transmitter and

(Continued on page 341)

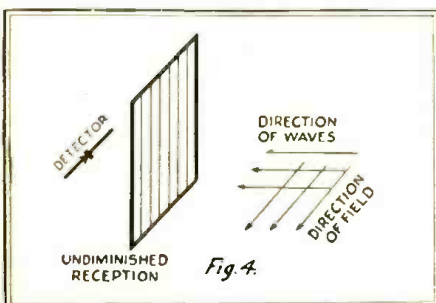

When this frame of parallel wires, at right angles to the wave front, is perpendicular to the electric field, it allows the waves to pass freely.

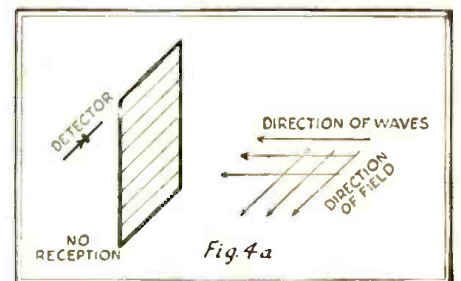

If, on the other hand, the wires of the Hertz "polarization grid" are turned until they parallel the electric field, they shield against it.

# Short-Wave Stations of the World

All Schedules Eastern Standard Time: Add 5 Hours for Greenwich Mean Time.

Meters	Kilo-cycles	Station
14.50	20,680	Monte Grande, Argentina. after 10.30 p. m. Telephony with Europe.
11.81	20,200	DGW, Nauen, Germany. 2 to 9 p. m. Telephony to Buenos Aires.
15.03	19,950	LSG, Monte Grande, Argentina. From 9 a. m. to 1 p. m. Telephony to Paris and Nauen (Berlin). —DIH, Nauen, Germany.
15.50	19,350	Nancy, France. 4 to 5 p. m. —FW3, Paris, France. From 10 a. m. Telephony to Monte Grande (Buenos Aires). —VK2ME, Sydney, Australia.
15.85	19,920	XDA, Mexico City, Mex. 12:30 to 2:30 p. m.
15.91	18,810	PLR, Bandung, Java. Broadcasts Wed. 8:40 to 10:40 a. m. Telephony with Kootwijk (Amsterdam).
10.10	18,620	GBJ, Godmlin, England. Telephony with Montreal.
10.10	18,620	PCK, Kootwijk, Holland. Daily from 1 to 6:30 a. m.
10.11	18,610	GBU, Rugby, England.
16.35	18,350	WNO, Deal Beach, N. J. Transatlantic telephony.
16.38	18,310	GBS, Rugby, England. Telephony with New York. General Postoffice, London.
16.50	18,170	CGA, Drummondville, Quebec, Canada. Telephony to England. Canadian Marconi Co.
16.51	18,130	GBW, Rugby, England.
16.57	18,120	GBK, Rugby, England.
16.61	18,050	KQJ, Hollins, Calif.
16.80	17,850	PLF, Bandung, Java ("Radio Malabar"). Works with Holland.
16.88	17,770	PHI, Hulzen, Holland. Beam station to Dutch colonies. Broadcasts Mon., Wed., Thurs., Fri. 8 to 11 a. m. N. Y. Phillips Radio, Amsterdam.
16.90	17,740	HSIPJ, Bangkok, Siam. Broadcasts 9 to 11:30 a. m.
17.20	17,440	Nauen, Germany.
17.34	17,300	W2XK, Schenectady, N. Y. Tues., Thurs., Sat. 12 to 5 p. m. General Electric Co.
18.10	16,300	PCL, Kootwijk, Holland. Works with Bandung from 7 a. m. Netherland State Telegraphs.
18.56	16,150	GBX, Rugby, England.
18.75	15,900	Salgon, Indo-China.
18.80	15,950	PLG, Bandung, Java. Afternoons.
19.56	15,340	W2XAD, Schenectady, N. Y. Broadcasts Sun. 2:30 to 5:40 p. m., Tues., Thurs. and Sat. noon to 5 p. m.; Fri. 2 to 3 p. m.; besides relaying WGY's evening program on Mon., Wed., Fri. and Sat. evenings. General Electric Company.
19.60	15,300	Lyangby, Denmark. Experimental.
20.00	14,990	TFZSH, Iceland.
20.50	14,625	W8XF, Pittsburgh, Penna.
20.80	14,420	VPD, Suva, Fiji Islands.
22.20	13,500	Vienna, Austria.
22.38	13,100	WNO, Deal Beach, N. J. Transatlantic telephony.
22.40	13,050	W2XAA, Houlton, Me. Transatlantic telephony.
23.35	12,850	W2XO, Schenectady, N. Y. Antipodal program 9 p. m. Mon. to 3 a. m. Tues.; noon to 5 p. m. on Tues., Thurs. and Sat. General Electric Co. —W6XN, Oakland, Calif. Relays KGO from 8 p. m. Mon., Wed., Thurs. to 2:45 a. m. Tues., 3 a. m. Fri., 4 a. m. Sunday. General Electric Co.
24.41	12,280	GBU, Rugby, England.
24.50	12,210	FW, Ste. Assise (Paris) France. Works Buenos Aires, Indo-China and Java. On 9 a. m. to 1 p. m. and other hours. —KIXR, Manila, P. I. —GBX, Rugby, England.
24.63	12,150	GBS, Rugby, England. Transatlantic phone to Deal, N. J. (New York).
25.10	11,940	Zeesen, Germany. Tests of new Super-power broadcasters.
25.40	11,800	W8XK, East Pittsburgh, Pa. Relays KDKA after 6 p. m. Tues. and Thurs. from 5 to 7. Westinghouse Electric Co.
25.53	11,750	655W, Chelmsford, England. Relays 2LO London. 2 to 7 p. m. experimental transmission from 7 to 9 p. m. and 7:30 to 8:30 a. m. and tests with W2XO 12 to 1 p. m. Mon. and Thurs. Silent Sat. and Sun. British Broadcasting Co.
25.60	11,710	CJRW, Whunheg, Canada. 5:30 to 8 p. m. daily. Sun. 1 to 2 p. m. Relays CJRW. James Richardson & Sons, Ltd.
25.68	11,670	KIO, Kahuu, Hawaii.
26.00	11,530	CGA, Drummondville, Canada.
26.10	11,490	GBK, Rugby, England.
26.22	11,430	DHC, Nauen, Germany (Berlin) Weekdays after 5 p. m. after 9 p. m.
26.70	11,230	WSBN, SS. "Levathan" and A. T. & T. telephone connection.
27.00	11,100	EATH, Vienna, Austria. Mon. and Thurs., 5:30 to 7 p. m.
27.27	11,000	Posen, Poland. Mon. and Thurs. 5 to 6 p. m. New station testing.

Meters	Kilo-cycles	Station
27.80	10,780	PLR, Bandung, Java. Works with Holland and France weekdays from 7 a. m.; sometimes after 9:30.
28.00	10,710	VAS, Glace Bay, N. S., Canada 5 a. m. to 2 p. m. Canadian Marconi Co.
28.20	10,630	PLE, Bandung, Java. Tests with Australia.
28.50	10,510	RDRL, Leningrad, U.S.S.R. (Russia)
28.80	10,410	VK2ME, Sydney, Australia. Irregular. On Wed. after 6 a. m. Amalgamated Wireless of Australia, Pennant Hills, N. S. W. —KES, Hollins, Calif.
30.00	9,995	Posen, Poland.
30.15	9,910	GBU, Rugby, England.
30.20	9,930	W2XU, Long Island City, New York.
30.50	9,830	NRH, Heredia, Costa Rica. 10:30 to 11:30 p. m. Amado Cespedes Marin. Abartado 40.
30.64	9,790	GBW, Rugby, England.
30.75	9,750	Agen, France. Tues. and Fri., 5 to 6:15 p. m.
31.00	9,680	7LO, Nairobi, Kenya, Africa. 11 a. m. to 2 p. m. Relays 655W, Chelmsford, frequently from 2 to 3 p. m. —Monte Grande, Argentina, works Nauen irregularly after 10:30 p. m.
31.23	9,600	LGN, Bergen, Norway.
31.26	9,590	PCJ, Hiversum, Holland. English programs Thurs. and Fri. from 7 to 9 p. m.; Sat. from 5 to 7 a. m. Other languages, Thurs. 1 to 3 a. m., Fri. midnight to 4 a. m.; Sat. 1 to 7 a. m. N. Y. Phillips Radio, Eindhoven, Holland.
31.28	9,580	VK2FC, Sydney, Australia. Irregularly after 4 a. m. N. S. W. Broadcasting Co.
31.38	9,550	Zeesen, Germany. Projected new station.
31.48	9,530	W2XAF, Schenectady, New York. Mon., Tues., Thurs. and Sat. nights, relays WGY from 6 p. m. General Electric Co. —W9XA, Denver, Colorado. Relays KOA. —Helsingfors, Finland.

(NOTE: This list is compiled from many sources, all of which are not in agreement, and which show greater or less discrepancies, in view of the fact that most schedules and many wavelengths are still in an experimental stage; that daylight time introduces confusion and that wavelengths are calculated differently in many schedules. We shall be glad to receive later and more accurate information from broadcasters and other transmitting organizations, and from listeners who have authentic information as to calls, exact wavelengths and schedules. We cannot undertake to answer readers who inquire as to the identity of unknown stations heard, as that is a matter of guesswork; in addition to this, the harmonics of many local long-wave stations can be heard in a short-wave receiver.—Editor.)

31.56	9,500	VK3LO, Melbourne, Australia. Irregular. Broadcasting Co. of Australia.
		—OZ7RL, Copenhagen, Denmark. Around 6 p. m.
32.00	9,375	EH90C, Berne, Switzerland. Mon., Tues., Sat. 3 to 4 p. m. —OZ7MK, Copenhagen, Denmark. Irregular after 7 p. m.
32.13	9,330	CGA, Drummondville, Canada.
32.40	9,250	GBK, Rugby, England.
32.50	9,230	FL, Paris, France (Eiffel Tower) Time signals 3:56 a. m. and 3:56 p. m. —VK2BL, Sydney, Australia.
32.59	9,200	GBS, Rugby, England. Transatlantic phone.

Meters	Kilo-cycles	Station
33.26	9,010	GBS, Rugby, England.
33.70	8,900	Posen, Poland. Tests Mon. and Thurs. 6 to 7 p. m.
34.50	8,690	W2XAC, Schenectady, New York.
34.74	8,630	WOO, Deal, N. J.
35.00	8,570	HKCJ, Manizales, Colombia.
35.43	8,450	WSBN, SS. "Levathan."
37.02	8,100	EATH, Vienna, Austria. Mon. and Thurs. 5:30 to 7 p. m. —HSIP, Bangkok, Siam. Tues. and Fri. 9 to 11:30 a. m.
37.80	7,930	DOA, Doberitz, Germany. 1 to 3 p. m. Reichpostzentramt, Berlin.
38.80	7,770	PCL, Kootwijk, Holland. 9 a. m. to 7 p. m.
39.98	7,500	AFK, Doberitz, Germany. —TFZSH, Reykjavik, Iceland. —EK4ZZZ, Danzig (Free State).
40.20	7,400	YR, Lyons, France. Daily except Sun., 11:30 a. m. to 12:30 p. m.
41.00	7,310	Paris, France ("Radio Vitus") Tests.
41.50	7,220	Zurich, Switzerland. Sat. 3 to 5 p. m.
41.70	7,190	GAG, Perth, West Australia. Between 6:30 and 11 a. m.
42.12	7,280	OZ7RL, Copenhagen, Denmark. Irregular. Around 7 p. m.
43.00	6,870	EAR 110, Madrid, Spain. Tues. and Sat., 5:30 to 7 p. m.
43.50	6,900	IMA, Rome, Italy, Sun., noon to 2:30 p. m.
43.68	6,860	VRY, Georgetown, British Guiana. Wed. and Sun., 7:15 to 10:15.
44.00	6,820	XC 51, San Lazaro, Mexico. 3 a. m. and 3 p. m.
45.00	6,600	Berlin, Germany.
45.20	6,630	WSBN, SS. "Levathan."
46.05	6,515	WOO, Deal, N. J.
47.00	6,380	CT3AG, Funchal, Madeira Island. Sat. after 10 p. m.
48.80	6,140	KZRM, Manila, P. I.
49.02	6,120	W2XE, New York City. Relays WABC. Atlantic Broadcoasting Co.
49.31	6,080	W2XCX, Newark, N. J. Relays WOR.
49.40	6,070	UOR2, Vienna, Austria. Testing Tues. and Thurs., 8:10 to 9:10 a. m. Wed. and Sat. after 6 p. m.
49.50	6,060	W2XAL, Cincinnati, Ohio. Relays WJW.
		—W9XU, Council Bluffs, Iowa. Relays KOIL.
49.70	6,030	W2XAL, New York, N. Y.
49.80	6,020	W9XF, Chicago, Ill.
50.00	6,000	EAJ25, Barcelona, Spain. Sat. 3 to 4 p. m. —RFN, Moscow, Russia. Tues., Thurs., Sat. 8 to 9 a. m. —SAJ, Karlsborg, Sweden. —Eiffel Tower, Paris, France. Testing 6:30 to 6:45 a. m., 1:15 to 1:30, 5:15 to 5:45 p. m., around this wave.
52.00	5,770	AFL, Beresdorf, Germany.
56.70	5,300	AGJ, Nauen, Germany. Occasionally after 7 p. m.
58.00	5,172	Prague, Czechoslovakia.
60.90	4,920	LL, Paris, France.
62.50	4,800	W8XK, Pittsburgh, Pa. Relays KDKA after 6 p. m. Works with 5SW 5 to 7 p. m. Tues. and Thurs. Westinghouse Electric Co.
61.22	62.50	meters—4,800 to 4,900 kc. Television. —W8XK, Pittsburgh, Pa.—WIXAY, Lexington, Mass.; W2XBU, Beacon, N. Y.; —WENR, Chicago, Ill.
65.22	66.67	meters—4,500 to 4,600 kc. Television. —W6XC, Los Angeles, Calif.
67.65	4,430	DOA, Doberitz, Germany. 6 to 7 p. m. 2 to 3 p. m. Mon., Wed., Fri.
70.00	4,280	OHK2, Vienna, Austria. Sun., first 15 minutes of hour from 1 to 7 p. m.
70.20	4,270	RA-19, Khabarovsk, Siberia. Daily except Wed. from 3 a. m.
72.87	4,116	WOO, Deal, N. J.
80.00	3,750	F8KR, Constantine, Tunis, Africa. Mon. and Fri.
84.21	3,560	OZ7RL, Copenhagen, Denmark. Tuesday and Fri. after 6 p. m.
91.76	3,166	WCK, Detroit, Mich. (Police Dept.)
96.03	3,124	WOO, Deal, N. J.
98.00	3,000	Motala, Sweden.
101.7	2,850	meters—2,850 to 2,950 kc. Television. —W3XK, Silver Springs, Md., 8 to 9 p. m. except Sunday. WPY, Allwood, N. J.
101.4	2,870	Perth, Australia.
103.3	2,750	meters—2,750 to 2,850 kc. Television. —W2XBA, Newark, N. J. Tues. and Fri. 12 to 1 a. m.—W2XCL, Brooklyn, N. Y.; —W8XAU, Pittsburgh, Pa.—WIXB, Somerville, Mass.;—W2XAO, Portland, Ore.
109.1	2,750	meters—2,750 to 2,750 kc. Television—
		—W9XR, Chicago, Ill.
136.4	2,100	meters—2,100 to 2,200 kc. Television. —W2XCR, Jersey City, N. J. 3 to 5 p. m. 8 to 10 p. m. except Sat. and Sun.; W8XAU, Pittsburgh, Pa.;—WIXB, Somerville, Mass.;—W2XCW, Schenectady, N. Y.
142.9	2,000	meters—2,000 to 2,100 kc. Television. —W2XCL, Brooklyn, N. Y. Mon., Wed., Fri., 9 to 10 p. m.—W9XAA, Chicago, Ill.;—W2XBS, New York, N. Y. frame 60 lines deep, 72 wide, 1,200 R.M.P.; WIXAE, Springfield, Mass.—W8XAU, Pittsburgh, Pa.;—W6XAM, Los Angeles;—W2XBU, Beacon, N. Y.;—W2XBW, Bound Brook, N. J.;—W3XK, Washington, D. C. Daily except Sun., 8 to 9 p. m.;—WPY, Allwood, N. J.
175.2	1,712	WKDU, Cincinnati, Ohio. (Police Dept.)
178.1	1,684	WKDX, New York, N. Y. (Police Dept.)
187.0	1,596	WQDT, Detroit, Mich. (Fire Dept.)

(Standard Television scanning, 48 lines, 900 R.P.M.)

# A Novel Scanning Disc for Television

*A new design of this fundamental unit which facilitates the work of synchronism for the experimenter and makes "framing" easier*

By PAUL L. CLARK

**T**HIS die-stamped aluminum disc not only accurately scans the picture through its spiral of holes (which are cut square and with sharp edges, in order to obtain maximum illumination and also to secure sharply delineated television images) but it also has a speed-indicator, built into one spoke of the disc and held in place by the hub (which bolts directly to the shaft of the small driving motor, as illustrated in the photographs reproduced here).

The technique of receiving television images resolves itself into but a few factors; the most successful results being obtained by using a simple form of equipment made up of a minimum number of standard parts. The necessary elements are: (1) a short-wave receiver with two stages of transformer-, or three of resistance-coupled, amplification producing an output voltage above 180, at 10 to 50 milliamperes; (2) a neon glow-lamp; (3) a small variable-speed motor; (4) a speed-control rheostat for motor; (5) a scanning disc and speed-indicator.

The motor should be of the universal, or of the D.C. type (such as are used in household appliances) if the scanning disc is to be bolted directly to the motor; but if an induction or a synchronous motor is to be used, some sort of friction drive must be provided, in order that the speed ratios of the motor and the disc may be varied at will by the operator.

### Why Is Synchronization Necessary?

Provided the experimenter's equipment is complete, as outlined in the above paragraphs, synchronization—speed control—remains undoubtedly the only single factor affecting television reception. And it was

with the idea of simplifying the speed problem of the television engineer, that this disc has been developed during the last year.

The standard scanning speed of stations

framed with the local and distant scanning systems running in perfect consonance, it is evident that, if this keyed-in consonance be lost by even the slightest disturbance

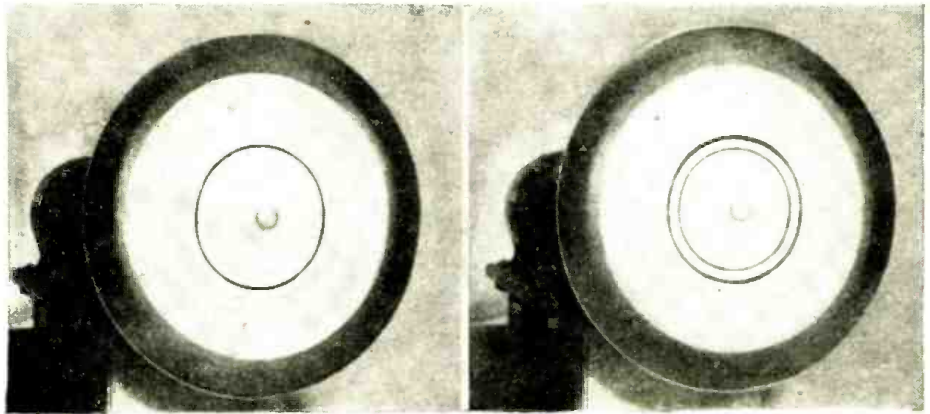

Fig. A

Fig. B

*At the left, the disc is rotating at 900 r.p.m., showing the appearance of the indicator under proper adjustment. At the right, the disc is off speed, and the speed-indicator ring fails to coincide with the permanent ring scribed on the disc.*

now broadcasting television is 900 r.p.m.; and (by referring to Figs. A and B) it will be seen that the disc has built into it a speed-indicating element which shows when this speed is attained; 900 revolutions being the theoretical speed at which the picture should register upon the scanning disc. Slight adjustments on the speed-control rheostat, however, one way or the other, must be made by the experimenter, to get his speed in agreement with that of the similar disc at the television broadcast station. Considering the picture as accurately

occurring at either the sender or the receiver, the picture will "travel" across the field of view, causing a "mis-frame," and in the twinkling of an eye it will disappear unless speed correction be effected by adjusting the rheostat.

### Framing the Image

The method in use by many progressive experimenters is to start up the small motor and slowly bring its speed to 900 r.p.m. by watching the indicator circle; at this speed the image should appear at the picture  
*(Continued on page 314)*

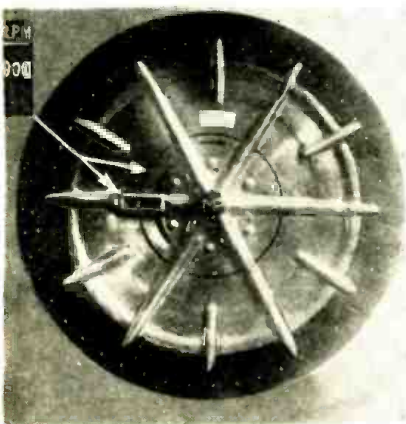

Fig. C

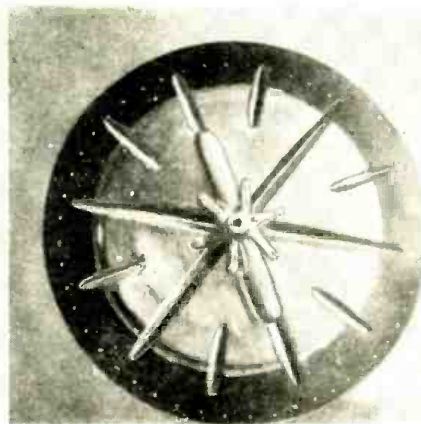

Fig. D

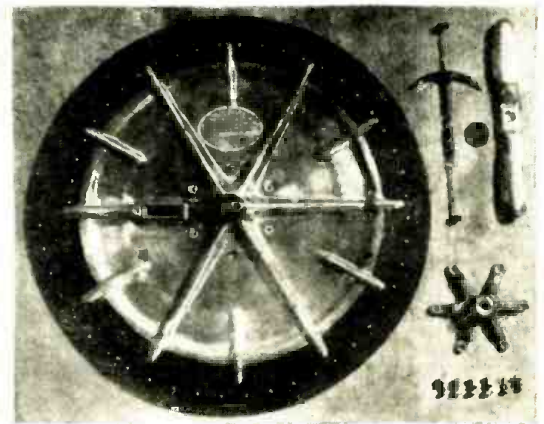

Fig. E

*At the left, the front of the disc described by Mr. Clark, showing the spring-controlled indicator, which is here turned horizontally, and the ring on the disc to which it is to be adjusted. In the central picture, we see the back of the disc, with the sheath under which the indicator slides; and the right photograph shows the parts of the simple assembly.*

# New Radio Devices for Shop and Home

*In this department are reviewed commercial products of most recent interest. Manufacturers are requested to submit descriptions of forthcoming developments.*

## HUBBELL TOGGLE SWITCH OF NEW CONSTRUCTION

**S**WITCH contacts are the important parts of a toggle switch. They should have prime consideration in selecting a switch whether the purpose is to control lamps or power equipment. The most frequent cause of switch failure has been burning of contacts at the "make." No switch contact spring could receive the enormous inrush of current at the instant of "make" without burning.

A radically new form of contact spring has been scientifically designed so that two different rates of vibration are set-up in the spring; one tending to counteract the other.

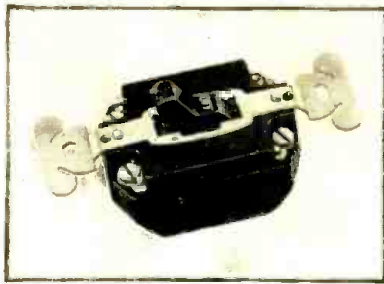

*Outside appearance of a new snap switch, which is designed to eliminate burning of contact points and should find ready acceptance by set builders.*

Thus recoil in the ends of the contact spring when the solid metal contact blade strikes between them is practically eliminated. As a result, burning and pitting of the spring is prevented.

An automatic "kick-off" prevents sticking of blades in contact. The commutator support is perfectly insulated, and the commutator blades are rigidly riveted to the carrier, insuring positive alignment.

The spring arm is pivoted on a round shaft, seated in a symmetrical bearing facilitating faster, smoother action without wear.

The operating mechanism is separate from the bridge and perfectly insulated. A solid bridge with ears lies in a recess across the bakelite cover—entirely insulated, perfect alignment and rigidity insured.

Each wiring terminal is held by two screws. A bakelite case completely encloses mechanism.

The catalog number, rating and price of each size follows: 9801, Single-pole, 5 amps. 250 volts; 10 amps. 125 volts, \$.55; 9802, double-pole, 10 amps. 250 volts, \$.90; 9803, 3-way, 5 amps. 250 volts; 10 amps. 125 volts, \$.70; 9804, 4-way, 2 amps. 250 volts; 5 amps. 125 volts, \$2.20; 9805, single-pole, 20 amps. 250 volts, \$.90; 9806, double-pole, 20 amps. 250 volts, \$1.00. These are made by Harvey Hubbell, Inc., Bridgeport, Conn.

## WESTON "MODEL 547 A.C.—D.C." TESTER

**T**HIS latest addition to the Weston line of testing instruments comprises a special six-range "Model 301" D.C. voltmeter, a double-range "Model 301" D.C. milliammeter, and a five-range "Model 476" A.C. voltmeter; also, a three-way selector switch and two bi-polar, 9-point switches. A battery, the tester plug, test prods, and converter receptacles fit into a compartment.

The over-all size is 12 $\frac{3}{4}$  x 9 x 3 $\frac{3}{4}$  inches; and the weight, 10 pounds.

With this tester, simultaneous readings can be made of the heater voltage on the A.C. voltmeter and the plate current on the milliammeter, while plate, bias or cathode voltages are being measured on the D.C. voltmeter.

Other tests which may be made include: D.C. filament voltage (range plus or minus 10 volts); A.C. heater voltage (4, 8 or 16 volts); D.C. plate volts (250 or 750 volts); D.C. biasing voltage (plus or minus 100 volts; or plus or minus 50 volts); D.C. biasing voltage on D.C. sets with reversed filament connection (50 volts); D.C. cathode voltage (plus or minus 50 volts); D.C. control-grid voltage (minus 5 volts or plus 100 volts); D.C. plate current (20 or 100



*Arrangement of the commutator parts and spring-arm of the new Hubbell snap switch described at the left.*

ma.); "grid test" on A.C. or D.C. screen-grid tubes and '27 used as detector.

The above tests may be made with the tester plug inserted in the radio set, while the following external tests employ the binding posts and flexible cables: Measurement from center tap of power transformer, 750 volts A.C.; line-voltage measurements, 150 volts A.C.; plate current at various "B" supply taps (on 20 or 100 ma. scale); "B" supply at power pack, 250 or 750 volts D. C.; "A," "B," or "C" potentials within the limits of the 5-10-15 scale D.C. voltmeter; plate current from left-hand plate of full-wave rectifier; continuity tests, using the self-contained 4.5 volt battery with either a 500-ohm or a 5,000-ohm resistor in voltmeter circuit; resistance measurements; measurement of trickle chargers and other devices, (the milliammeter's range may be read as 2 or 10 amperes by use of shunts which are available separately).

To dealers, the net price of this instrument, made by the Weston Electrical Instrument Corp., Newark, N. J., is \$93.75.

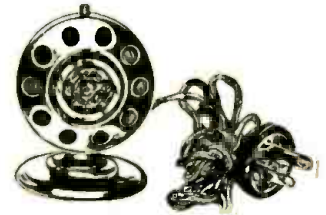

*The "Mike-Lite," a desk novelty with a utilitarian slant which will be appreciated by those who smoke. It is a most acceptable gift.*

## ENTER—THE "MIKE-LITE"

**F**EW and far between are the desks of technical men which do not sport upon their tops some device that indicates to the knowing observer just what branch of science is of particular interest to the technician.

Combining utility with a novelty which will appeal to radio men, the new "Mike-Lite" placed on the market by A. M. Flechtheim & Co., Inc., New York City, is worthy of special mention.

The "mike" is in reality a cigar lighter. It is available in a one-dollar style (a faithful reproduction of a modern broadcast studio microphone); and in a two-dollar model, which has also an ash-tray.

Both are designed for operation from the light socket, on 110 volts, either A.C. or D.C. There is a choice of finish, the colors being in baked enamel. A silk cord and attachment plug are furnished.

As Christmas gifts for technical men who smoke, these lighters are finding tremendous demand.

Since the "Mike-Lite" is ruggedly built, there is little danger of breakage, should it be knocked over in the discharge of its duties as, perhaps, a paper-weight. Of the two models, that with the ash-tray attachment is most often selected.

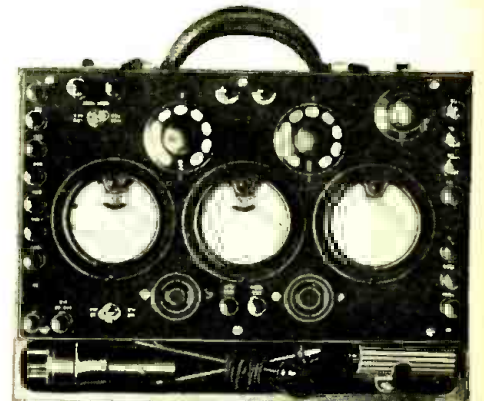

*The Weston "Model 547 A.C.-D.C." tester as it appears when the cover is removed. It tests both A.C. and D.C. screen-grid tubes.*

# Television Images in Natural Colors

*A description of the use of sodium photoelectric cells and argon-neon lamps for the demonstration of three-color television over wires in the Bell Telephone Laboratories*

By DR. HERBERT E. IVES

*Research Department, Bell Telephone Laboratories*

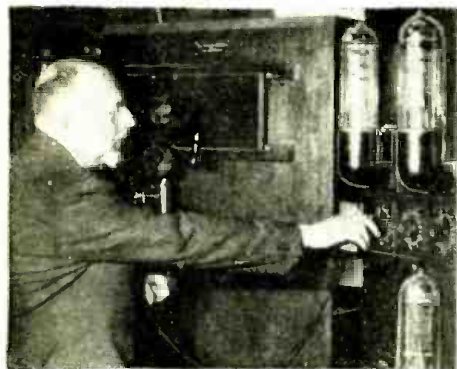

Fig. E

*Dr. Ives adjusting the "volume and quality" of the visual output of the receiver. The largest amplifier tubes are at the right.*

**T**HERE are two methods of television transmission in general use; one by radio and the other by wire. The laboratory usually develops its equipment "on wire" and transfers it to a radio circuit after the initial difficulties have been ironed out. This was the plan followed in the development of natural-color television, the demonstrations to the representatives of the press being given over a wire.

Reproduction in the monochrome of the orange-red neon lamp is an old accomplishment. The new feature, combined blue, green and red response, is obtained by the use of the old machine (driving motors, scanning discs, synchronizing systems, and

the same amplification circuits) plus a special design and arrangement of photoelectric cells and "noble gas" (neon and argon) lamps.

### The Olpin-Stilwell Cell

Through the work of A. R. Olpin and G. R. Stilwell there has been developed a new kind of photoelectric cell (Fig. B) which uses sodium in place of potassium. Its active surface is sensitized by a complicated process using sulphur vapor and oxygen, instead of by a glow discharge of hydrogen as with the former type of cell.

The response of the new cell to color, instead of stopping in the blue-green region, continues all the way to the deep red. Because the former potassium cells were responsive only to the blue end of the spectrum, objects of a yellowish color appeared darker than they should, and the tone of the reproduced scene was not quite correct. (This disadvantage applied particularly to persons of dark or tanned complexion.) When the new cells are used in the original



Fig. B

*Light-sensitive cell with filter drawn partly out. Banks of these are used. (See Fig. C.)*



Fig. F

*"Symphony in Blue"—green, red, and all the other colors of the rainbow.*

television apparatus but with yellow filters—similar to those used in photographing landscapes in order to make the blue sky appear properly dark—this defect is corrected and the images assume their correct values of light and shade, no matter what the color of the object or the complexion of the sitter.

The development of color television has been greatly simplified by the fact that, so far as the eye is concerned, any color may be represented by the proper mixture of just three fundamental colors—red, green, and blue (this fact was utilized in the development of color photography).

The method of "beam scanning" used in regular television has been employed.

### Color Filters

To apply this method to color television, three sets of photoelectric cells, C1, C2 and C3, in Fig. A, are used in place of the one set used before. Each of these sets is provided with color filters ("A," "B," and "C") made up of sheets of colored gelatine. One set has filters of an orange-red color which make the cells "see" things as the hypothetical red-sensitive nerves of the retina see them; another has yellow-green filters to give the green signal; while the third has greenish-blue filters which perform a corresponding function for the blue constituent of vision.

The photoelectric-cell container, or "cage," has been built into a new form. (Fig. C.)

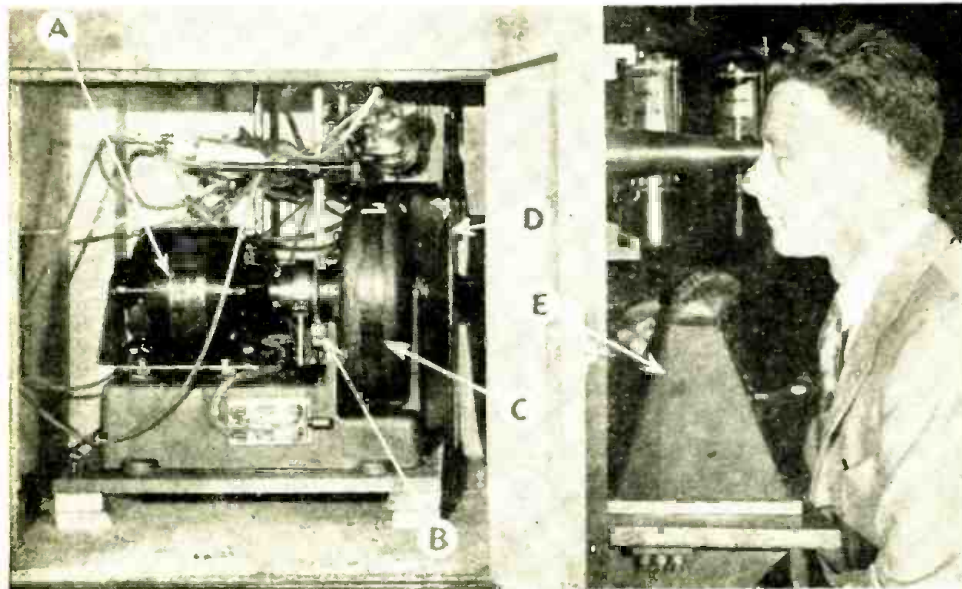

Fig. H

*View of the receiver equipment; A, driving motor; B, gears for framing the image; C, synchronizing motor-generator (which connects to a similar part in the transmitter, variation in the speed of either causing a reaction which tends to equalize the speed); D, 50-hole, 1080-r.p.m. disc; E, light shade. The lamps and special (encased) mirrors are at upper right.*



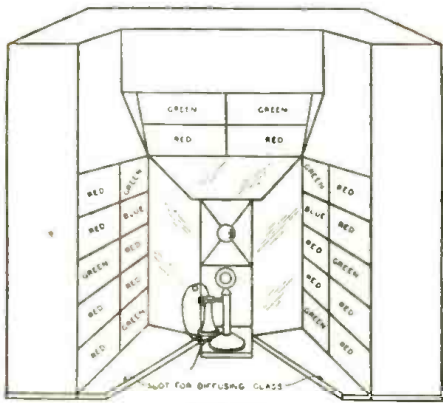

Fig. C

The grouping of the color filters, in front of the color-sensitive photoelectric cells, is shown in this perspective sketch of the television transmitter.

**Balancing the Color Pick-up**

In the new photo-cell cage twenty-four cells are employed; two with "blue" filters, eight with "green" filters, and fourteen with "red" filters. These numbers are so chosen, with respect to the relative sensitiveness of the cells to different colors, that the photoelectric signals are of about equal value for the three colors. The cells are placed in three banks; one bank in front of and above the position of the scanned object, one bank diagonally to the right, and another diagonally to the left; so that the cells receive light from both sides of the object and above. In placing the cells they

are so distributed by color as to give no predominance in any direction to any color. In addition, sheets of rough pressed glass are set up at some distance, in front of the cell containers; so that the light reflected from the object to the cells is well diffused. (Fig. F.)

The television signals produced in the color-sensitive photoelectric cells through the color filters are not different electrically from those used in monochromatic television. Three sets of amplifiers are required, one for each color, and three transmission channels in place of one; but the transmission channels are exactly similar to those which were used with the same scanning disc before. (Fig. D.)

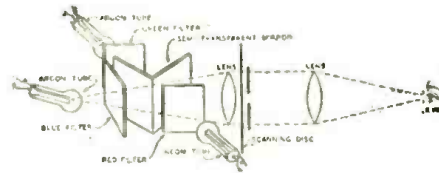

Fig. G

The lens picks up at once red light from the neon tube, reflected from one mirror; green from one argon tube, also reflected; and blue, from the other argon tube, which shines through both mirrors.

**Comparison Between Scanning Methods**

It may be well to point out that there are two fundamental systems in use for the process of picture "pick-up;" one is just the reverse of the other. In one method,

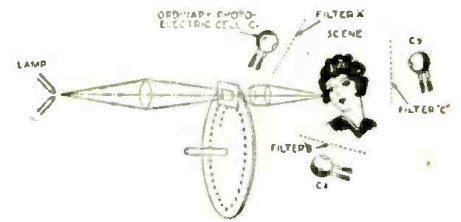

Fig. A

In this is seen the ordinary potassium light-sensitive cell, C1, to which has been added filter "A." Special sodium photoelectric cells C2 and C3, in conjunction with filters "B" and "C," are required to obtain additional color selection.

the scanning disc breaks into lines, the light reflected from the subject; in the other (Fig. A) the disc projects, as lines, the illumination from the light source. In the former method the subject is exposed to a continuous light of high intensity which results in what is equivalent to a sunburn. In the latter method, the subject is rapidly scanned by a pencil of light and "sunburn" does not result. This is the scheme adopted by the Bell Laboratories, as most satisfactory.

It will be noted that the location and relation of the photoelectric cell and the light source are reversed in the two methods; the photoelectric cell is back of the scanning disk in the former, and the light source replaces it in the latter.

As each "color" (frequency) has its own amplifier, the "color gain" may be controlled and the colors "mixed" in much the

(Continued on page 345)

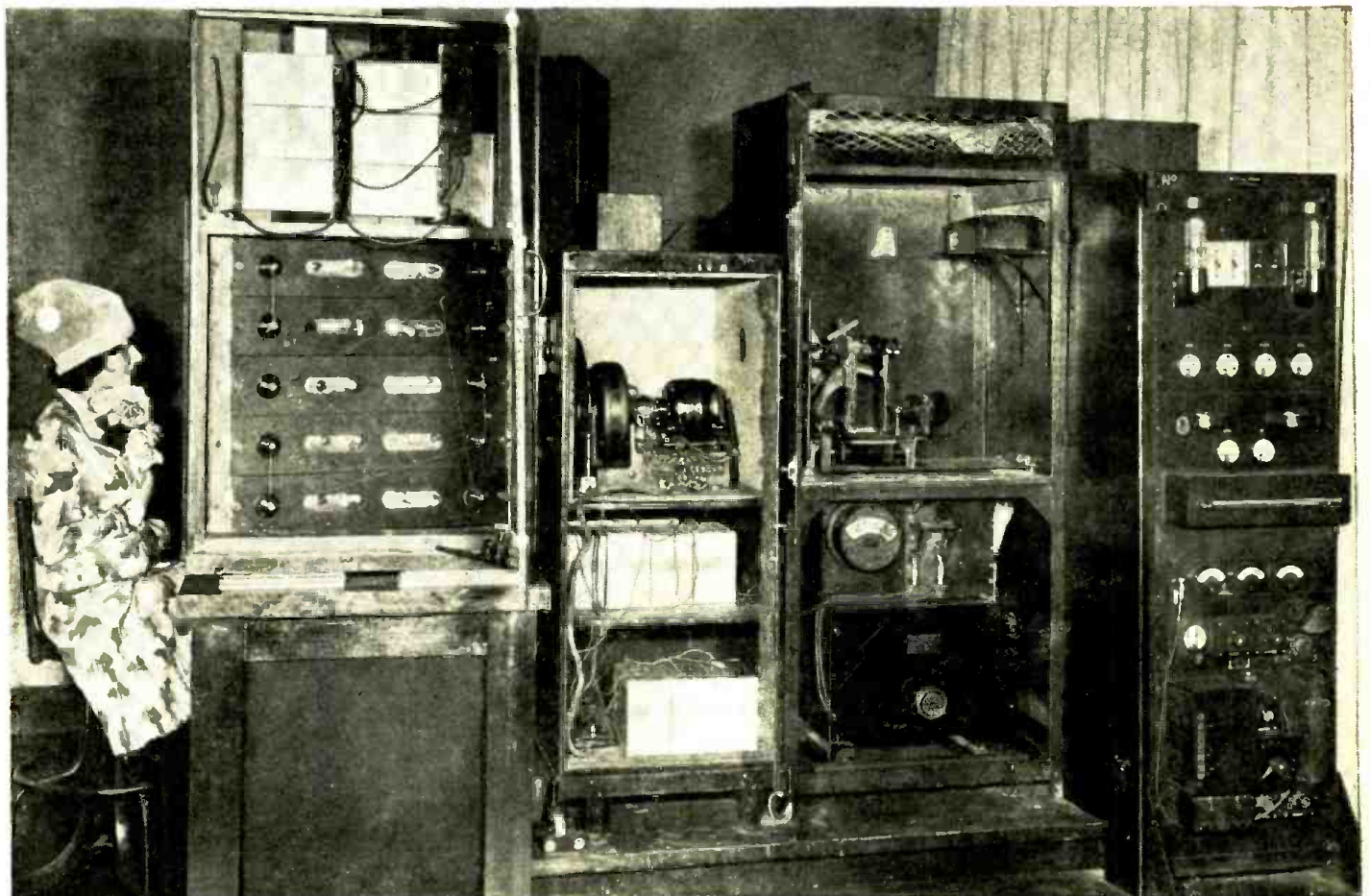

Fig. D

Side view of transmitting scanning disc, its motor, synchronizing motor-generator, power amplifiers, motor and amplifier controls, direct-current supplies, lenses, translucent glass, filters, and photoelectric cells with doors of cabinets opened. All but the cells and the box containing the diffusing glass and filters are the same as in the transmitting units used in the original demonstration of monochromatic television. The girl subject wears apparel of gay colors.

# The Development of the Modern Sound Reproducer

*In this continuation of his article on the development of the electrostatic principle, Mr. Roos describes the simple, yet ingenious and effective, improvement made by Colin Kyle and embodied in the latest American reproducers*

By OSCAR C. ROOS

**I**N the first part of this article, which appeared in the November issue of *RADIO-CRAFT*, the successive steps in the development of electrostatic and multiple-unit reproducers, and some of the acoustic problems arising from the nature of sound-waves in air, have been discussed. We now come to the latest revolutionary invention, which combines the two principles effectively.

The development of the "mesh-unit" reproducer seems to have been logically necessitated by the use of smaller and smaller pistons to escape the alternative of enormously high radial stresses in sectionalized diaphragms, such as that shown in Fig. 9.

It must be remembered that, with a polarized diaphragm, the fidelity of the response to an audio-frequency signal must depend on the mechanical elasticity of the diaphragm. If the audio-frequency voltage were created and reversed instantaneously, the diaphragm could fly back to its polarized position only in accordance with its own natural characteristics. All we can

do is to increase its elasticity by applying high radial stresses—provide a satisfactory response at 15,000 cycles, and let it go at that. The more tense the diaphragm, the greater the fidelity. In some instruments the radial strain is 2,200 pounds on each inch of the diaphragm's width; but, no doubt, under long periods of heavy service, the metal will develop molecular instability ("crystallize"), and require periodical replacements.

Eugen Reisz was at the cross-roads of two new lines of development. In his "granule-piston" reproducer, previously described and illustrated in Fig. 10, he made his "piston units" out of single solid granules; but it has since been shown that there is a lack of strictly parallel operation in the myriads of these granules.

On the other hand, his "air-vent piston" reproducer (shown in Fig. 11) was one of the earliest of successful modern designs; its flexible rubber membrane M, covered with a conducting substance G, "fans," so to speak, the air waves through the circular holes H

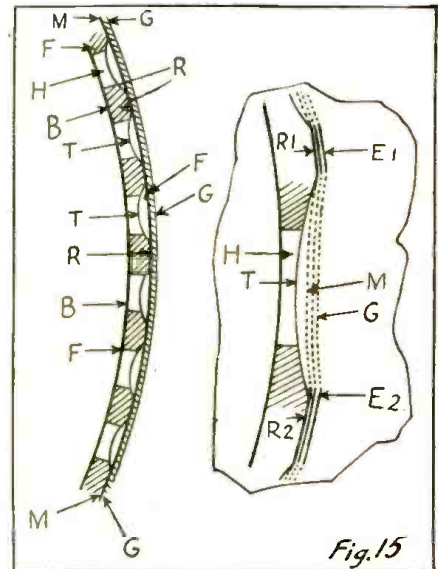

*The curvature of the fixed-frame electrode F keeps in place the stretched dielectric M; which is nevertheless allowed a flat conformation by the groove T.*

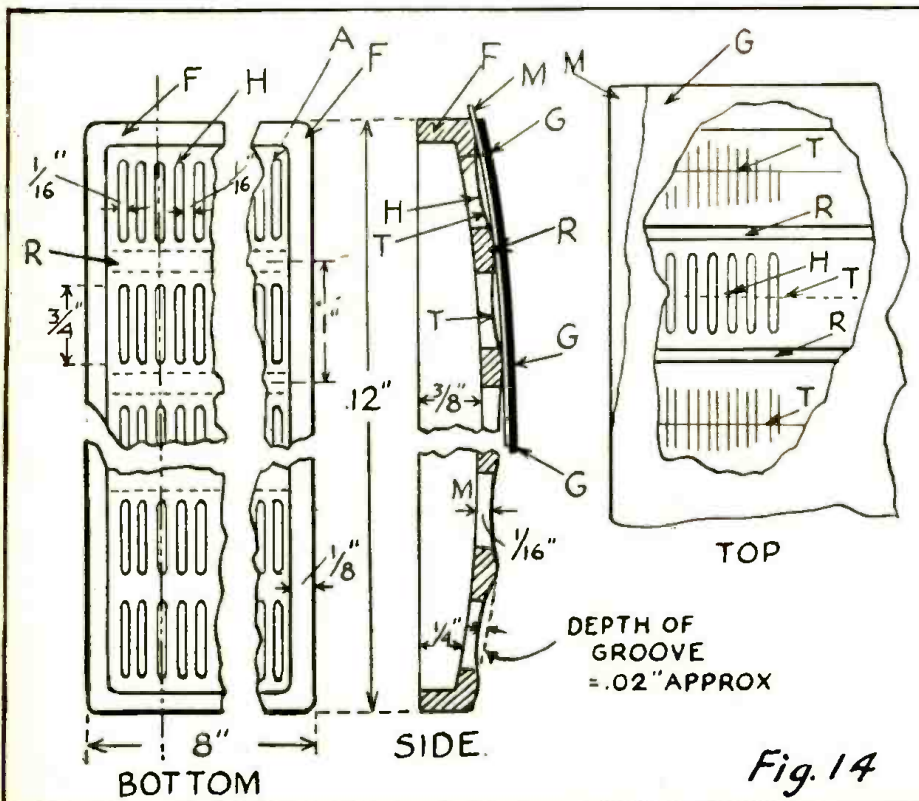

*The complete mesh unit, the arrangement of which is indicated above, has a frame 8 x 12 inches with fifteen rows, each of 45 "goat-eye" perforations, 1/16 x 3/4-inch, acting as air-pistons. This makes a total of 675 piston-vents, through which air is pumped; they are separated 1/16 inch at each side, and 1 inch between rows. More detail is shown in Fig. 13.*

which pierce the thin, curved tin plate F. Thus G and F are the armatures; the holes in the latter have curved convex sides (the depth of which is exaggerated in the drawing to make the arrangement plain). When M is drawn into the holes H, the air in these acts like so many practically weightless pistons. The attraction of their curved edges for the conductor G (gold-foil, graphite, etc.) makes the central section of the membrane, over the hole, take an almost flat shape, with resulting greater efficiency and fidelity. The molecular damping in the membrane M also contributes to increased fidelity by preventing undesired vibrations.

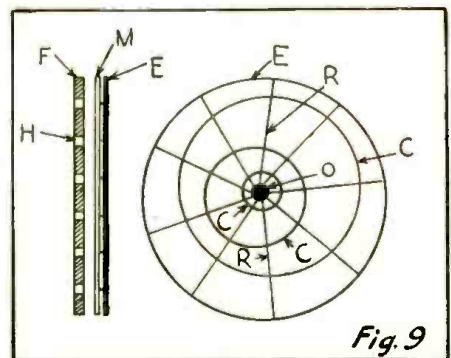

*Above, one of the European designs of an electrostatic reproducer: the membrane E is stretched tightly over the eccentric circles C, so that it cannot vibrate in radial segments.*

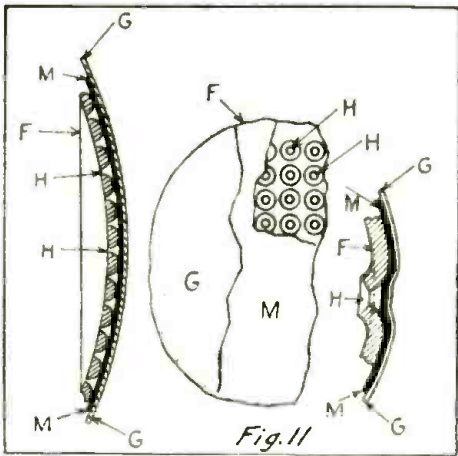

In the Reisz unilaterally-driven reproducer, above, the "piston-vents" are circular holes punched through a convex, saucer-like disc of metal, whose thickness is exaggerated here.

**The Kyle Reproducer**

It does not appear that Reisz fully appreciated his opportunity here; and it remained for an American school teacher, Colin Kyle, to approach perfection in acoustic fidelity, most remarkably, by the use of the "goat-eye" type of mesh-unit reproducers. From a study of Figs. 12 to 15, it will be seen why practically-ideal piston action is obtained over the range of audible frequencies.

In Fig. 12, a schematic section of a crude, undeveloped form of the Kyle reproducer, we find a convex, rectangular frame instead of the round ones previously used; on this frame F there are parallel ridges R, about 3/8-inch apart. The flexible armature G is tightly connected to the dielectric membrane M, and both are supported by the ridges R so that they do not come in contact with the floor H of the grooves.

If we compare this with the similarly-lettered section of the Reisz speaker shown in Fig. 11, we shall see that the membrane M in the latter is at all times in close contact with the piston holes H, and therefore the amplitude of the sound is cut down because of the confinement of the air. But in the Kyle unit (Fig. 12) the whole rectangular strip of the membrane M between any two ridges R is kept entirely away from about 92% of the piston-hole edges for most of the time. These holes are shaped like "goat-eyes," 3/4 x 1/16-inch; and the membrane M never touches the bottom of the groove at its middle, or trough, except under the very strongest signal impulses. This means that there is less compression

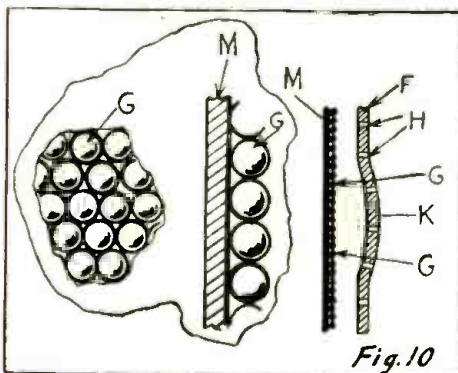

The Reisz elastic-diaphragm speaker, in which one plate is formed by conductive granules imbedded in an insulator, yet free to move otherwise.

resistance and more available amplitude than in the Reisz system. Further advantage is gained by the fact that every groove has two air vents in the frame F, one at each end.

The mesh-unit F of Fig. 12A is, in practice, a frame 8x12 inches, with 15 grooves having 15 "goat-eyes" each—a total of 675. Four of these units are usually sufficient for home use; but as many as 95 such units, making a reproducer *twelve feet square*, have been satisfactorily assembled, giving 61,800 small pistons acting in strict phase over a plane front. Thus we see vindicated Fessenden's theory of multiple units (See Fig. 3, part 1).

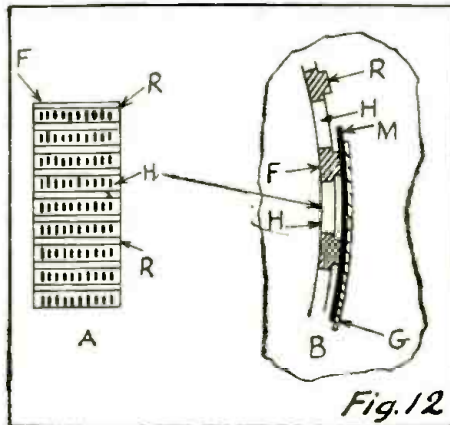

While the mesh-unit principle is illustrated here, the ridges between the "piston-vents" illustrated here are not of the best shape. It is an early model.

**Curving the Frame**

If we examine Figs. 14 and 15, we shall find a further slight advantage in using a partly cylindrical frame F, rather than one which is flat, as in Fig. 13, or part of a sphere, as in Fig. 11. The membrane M is concave when the armature plates F and G are unexcited; when the polarizing potential of 300 to 800 volts is put on, there is more stretching in the flexible members toward the "goat-eyes" of the cylindrical frame than in either the flat or the spheroidal models.

There is an advantage to be derived by using for M a material having a dielectric constant of 2 to 3; this gives a greater pull than using air as a dielectric, between F and G.

The trick of bringing F and G together by bevels near the edge, and drawing the electrified membrane into a plane surface near its middle, was used by Massolle in a circular diaphragm; but abandoned in later European designs.

One manufacturer who heard a mesh-unit speaker was so incredulous, because of the simplicity of the construction, that he insisted on being shown the "concealed motor"; a real tribute to the extraordinary simplicity of the electrostatic reproducer.

If these instruments can be sold for \$20 to \$75, they will severely affect conditions in the competitive market of 1930. We must not forget, however, that a swarm of improvements in electrostatic reproducers may follow, more rapidly than they did in the magnetic type, because of the simplicity and cheapness of the former.

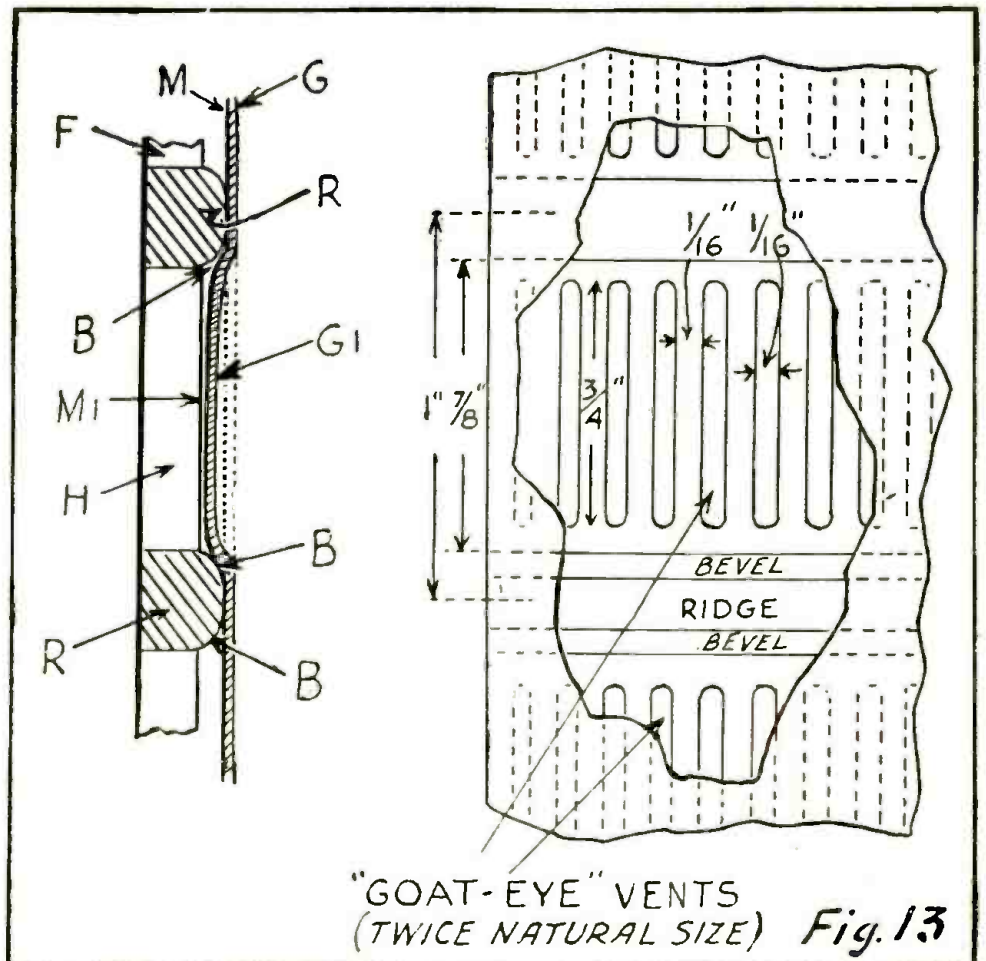

"GOAT-EYE" VENTS (TWICE NATURAL SIZE) Fig. 13

The construction of a mesh-unit reproducer shown above, with a flat fixed electrode F, is very easy; but the result will be imperfect and buzzing reproduction. The reason is that the plate voltage pulls the diaphragm into a concave shape, instead of permitting it to remain flat. The principal attraction is toward the shoulders B-B.

# Uses of D.C. and A.C. Screen-Grid Tubes

*A summary of the factors entering into the design of amplifier circuits for the efficient utilization of four-element tubes*

By J. A. DOWIE, Member I.R.E.  
 Chief Instructor, National Radio Institute

**T**HE screen-grid vacuum tube, first offered to the American public late in 1927, and one of the major contributions which science has made to the radio industry, is a distinct departure from the conventional type of three-element vacuum tube. The unusual characteristics and performance obtained from this tube are made possible by the introduction of a fourth element, or second grid, of novel design. This extends between the first grid (which is of the usual type) and the plate, and it is also carried over outside the plate. Thus, the plate is completely shielded or screened from the control-grid by the screen-grid.

If the plate is left disconnected and the screen-grid is used as the "anode" (plate) electrode, the '22 type (D.C. screen-grid) tube operates in a manner exactly similar to the ordinary three-element vacuum tube. It has then an amplification factor of 6.5 and a plate resistance of 15,000 ohms.

### The D.C. Tube

When the '22 is used as a four-element tube, a voltage of approximately 45 is applied to the screen-grid, and a higher voltage, 90 to 135, to the plate. The filament in this tube is rated at 3.3 volts, 0.132-ampere; when it is used as a radio-frequency amplifier only, it may be operated from an A.C. source by means of a step-down transformer.

This tube may be used as a detector with a grid leak and grid condenser, or with a grid bias. Resistance coupling is then recommended, as this gives a very satisfactory

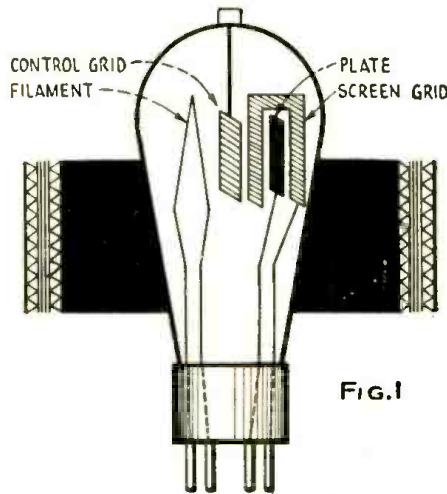

As screen-grid tubes acquire a silver-like interior surface during evacuation, it is difficult to visualize the interior construction. The relation of the four "elements" is shown in this figure.

frequency-characteristic because of the high internal resistance of the tube.

The '22 was especially designed as a radio-frequency amplifier. When it is so used, the most important advantage gained is elimination of all feed-back ordinarily caused by coupling between grid and plate due to the capacity between these elements. It is also possible to obtain higher voltage amplification per stage; 20 to 50 in the broadcast range, as compared with the usual range of 5 to 12 per stage with three-element tubes.

Although the internal shielding prevents feed-back through the tube's inter-electrode capacities, this is only one source of coupling between stages; so that it becomes necessary also to shield the input circuit from the output circuit. The amount of shielding necessary will depend upon the voltage amplification per stage and the circuit arrangement. A typical D.C. screen-grid receiving circuit is shown in Fig. 2. A metallic shield enclosing each tuned stage is usually sufficient but, if further shielding is found necessary when the voltage amplification is high, then a metal cap over the tube, extending to the base, and connected to the ground, should be used. Clearance for the grid connections must be provided at the top.

The tube may also be used as an audio-frequency amplifier with resistance coupling, the connections being the same as when it is used for radio-frequency amplification.

### How the Tube Functions

In a three-element vacuum tube, with the grid at zero potential, only a limited number of electrons reach the plate under the influence of the positive charge on the latter. The limiting factor is a cloud of electrons surrounding the filament and forming what is known as the *space charge*; these are *negative* in polarity and tend to drive other electrons back into the filament.

When the grid is charged negatively, it repels some of the electrons approaching it and thus reduces the total number reaching the plate and, thus, the plate current. As the grid is considerably closer to the filament, it exerts a greater influence on the electron flow, and also on the space-charge density, than does the plate.

When the grid is charged *positively*, it increases the total electron flow far more than the plate would do if the positive charge on the latter were increased the same amount; because the grid is closer to the filament and its positive charge breaks up the negative space charge more effectively than the comparatively distant plate can.

The sensitivity of the control exerted by the grid (and hence the amplifying value of the tube) is definitely limited by the electrons surrounding the filament. If an extra grid is interposed between the filament and the regular control-grid, and charged positively, it will (by virtue of its proximity to the filament) break up the space-charge and increase the controlling influence of the regular grid.

The extra grid may also be located between the control-grid and the plate. Here it will require a higher positive charge than before, but it now also serves another pur-

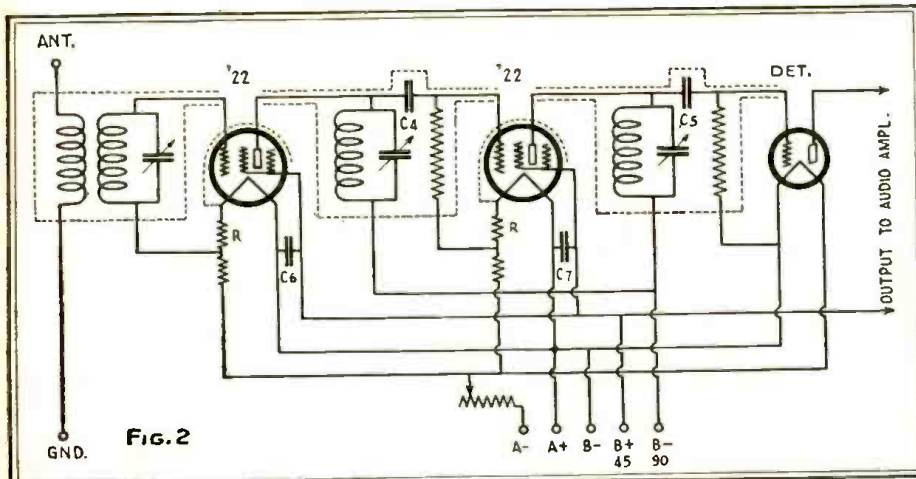

FIG. 2

In this diagram the use of screen-grid tubes in a D.C. circuit is shown; two stages of "tuned impedance" R.F. amplification develop very high gain. The "control-grid" bias is obtained from resistor R. The usual '01A tube is used for detection. Dotted lines indicate recommended circuit and tube shielding.

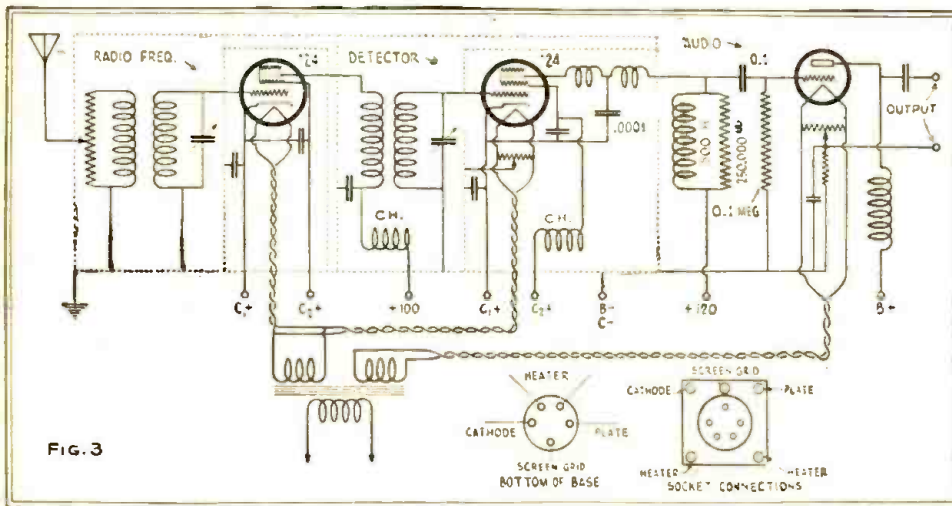

FIG. 3  
This circuit illustrates two applications of A.C. screen-grid tubes: transformer coupling has replaced the tuned impedance in the R.F. coupler. Note the type '24 detector. (Primary of second R.F.T. has about one-third the number of secondary turns.) For satisfactory operation it is necessary to use extremely high plate-circuit impedance: in the audio input, a 500-henry choke (A.F. transformer secondary) is recommended by the author.

pose; namely, to reduce the troublesome capacity effect between the grid and plate. It acts as a grounded center plate, splitting the fixed condenser formed by the grid and plate into two smaller condensers in series.

In commercial models of the four-element

tube ('22 type), the extra grid, known as the screen-grid, encircles the plate completely; the inner section acts both as a space-charge disrupter and as a capacity reducer, while the outer section (which has nothing to do with the screened electrons because they stop at the plate) serves merely

to reduce the capacity between the outside of the plate and the connecting lead. Therefore, it can be seen that the advantage of the screen-grid tube is that it reduces both the space charge and the internal grid-to-plate capacity. This greatly improves the action of a vacuum tube, and makes it possible to obtain much higher amplification.

The A.C. Model

Recently a new A.C. screen-grid tube has been placed on the market, and is known as type '24. This tube is designed primarily as a radio-frequency amplifier and high-output bias detector. The design is similar to that of the type '22, in that it has a second grid of novel design which extends between the usual grid and plate, and also carries over the outside of the plate to give extremely good shielding between the control grid and the plate. The grid-to-plate capacity has been reduced to .01-mmf. (maximum) allowing high amplification per stage without neutralization. (In three element tubes this capacity is about 9 mmf.)

This new tube has a unipotential cathode (as in the '27 type) which is raised to the temperature of emission by means of a heater filament operated on 2½ volts, A.C., and requiring a current of 1.75 amperes. This tube has been designed to operate at plate voltages between 135 and the maximum of 180; the screen-grid voltage should  
(Continued on page 346)

## The Seven-Grid Vacuum Tube !

SINCE the advent of the screen-grid tube which, is, really, a double-grid tube, engineers and constructors all over the world have been wondering why tube constructing should stop here. Why not a triple-grid tube, quadruple-grid tube, or even a septuple-grid tube?

There is, indeed, no reason for not having seven grids; any more than there would be for having a single dimension when we can really have two, three—perhaps four and five dimensions. And, even though we do not know what the fourth dimension is, there is no scientific reason why we can not build a seven-grid tube. Indeed, such a tube has now been built by a German radio engineer; the constructor being no less than the distinguished Baron Manfred von Ardenne, who directs a well-known Berlin experimental radio laboratory.

The tube is shown in the double illustration at the lower right. Some technical data may not be amiss: for it is certain that this tube will prove so revolutionary that by next spring it will have superseded every other design on the market.

The simple reason for this statement, revolutionary in itself, is that with this tube no others are required.

The amplification, as may be guessed, is of such titanic ratio, that not even an audio transformer is required to make the signals audible.

As our readers, no doubt, wish to have some technical information upon this new giant, the following may not be amiss.

The tube is of the usual construction and contains a single thoriated filament. In order to make it work at an exceedingly low filament-voltage, the inventor has incorporated within the filament, a number of radium electrons which make for extra high emission. Indeed, by this means, the filament voltage becomes entirely negligible; it becomes, under certain circumstances, what is known as "negative filament voltage." This may be explained by the exceedingly high "mu" (amplification factor) of the tube. Indeed, in this present tube, due to this negative filament voltage, an entirely new formula had to be built up, which may be expressed as follows:

$$\frac{7\mu^7 \cdot -\delta E_g^{14} \sqrt{-\mu}}{\pm r_1/r_7 \sqrt{\pm \mu \mu \mu \mu \mu \mu \mu}}$$

Mathematicians will readily understand this formula, and will realize that it does not come into conflict with Newton's conservation of the law of energy.

Characteristics of the Tube

Since we have seven grids, seven different grid biases are needed. These are furnished by the amplification factor of the complete resistance, making the ratios of the change of the plate voltage a double "mu" factor.

The plate resistance may be calculated by the ascertained values of the grid biases minus the filament voltage, which, in this case, is of the negative variety. The amplification factor of the tube must ipso facto be multiplied by seven; the result then multiplied by the minus figure.

This, as will be readily appreciated, gives a very high electron efficiency per square centimeter under normal atmospheric pressure; and the result is a flow of between  
(Continued on page 346)

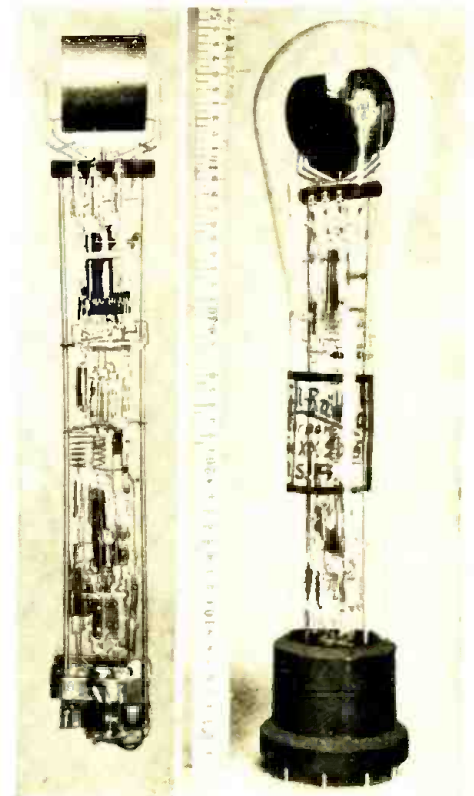

Baron von Ardenne's new tube, at the right; a view of its elements at the left. The 50-cm. (20-inch) mark on the rule shows its enormous length.

**IMPORTANT!**  
BEFORE writing us to ask where the new Von Ardenne tube may be purchased, our readers should consult the last paragraph of this article.

# Vacuum Tubes for Radio Reception

*Mr. Palmer describes, in his fourth article, the methods employed to assure the quality of modern tubes by automatic inspection, and gives the design of a useful home tester*

By C. W. PALMER

ONE of the most interesting studies in the manufacture of radio tubes is that of handling and testing the great number which are shipped daily. In the first article of this series the fact was mentioned, that the tubes which are returned to the factory for replacement are subject to certain tests, and that many of the tubes which are replaced are found to have been injured by misuse.

The methods by which the engineers in charge determine how the tube became inoperative should be of interest to most of our readers. The manufacturer is naturally concerned with the returned tubes; as he wishes to locate the sources of the most frequent faults. A number of special instruments have been developed to facilitate this work. First, the tube is examined to discover which unit of the plant made it; almost all makers put code numbers on tubes.

Next, the tube is subjected to a number of tests, similar to those described in preceding articles, in order to obtain its actual characteristic curves. These tests measure the mutual conductance, plate current, filament emission, hum, gas content, leakage current, etc.; in this way, the tube's deviation from the standard is determined; and then the tube is taken apart in order to locate the exact cause of its failure.

In case the filament circuit is found open, for example, it is possible to tell whether the tube was short-circuited, or whether it was subjected to unduly high voltages. The filament is placed under a microscope and its condition is noted; if it is burnt-out, the end is found to be tapered at the point of frac-

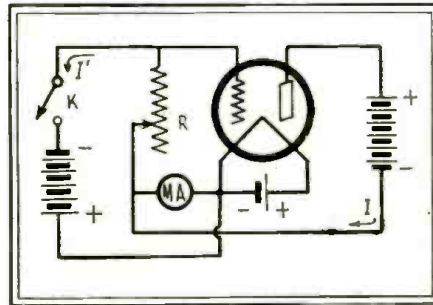

Fig. 1

*This circuit makes it possible to test quickly individual tubes to determine their mutual conductance, the best index to their quality.*

ture. If a short-circuit occurred, between the filament and the grid, a small darkened or broken spot on the grid tells the story. Many tubes are injured or made inoperative by mis-handling; if the tube is dropped or jarred badly, the elements are often knocked out of place. This causes a change in the characteristics; even though the filament is not broken or the "envelope" (bulb, etc.) cracked. The tests of the characteristics of the tube soon reveal this defect. A record of the cause of breakdown is kept and, if a number of the tubes made by the same machine unit are returned, the cause of the trouble is looked into at that stage of the process; and if possible, the weakness is overcome.

Manufacturers are doing their part to produce perfect tubes through rigid inspection, careful testing of material and finished products, and ample packing. Every piece of material which enters the tubes is first subjected to exhaustive tests to determine its quality and purity. Each tube is tested before it leaves the factory; in some cases, the tubes are given several complete tests, at different steps of manufacture, or samples are taken from each lot; and if one defective tube is found the entire lot is re-tested. More and more attention is being paid to the packing; "drop tests" with cases of tubes are made to be sure that the cushioning is adequate.

### A Simple Tube Tester

It may be said that the one measure of a tube's characteristics, which is better than any other single indication, is its mutual conductance. In the November issue, the writer gave a simple method for measuring the leakage current and the gas contents of a tube; this test is very good and is of service in checking a great number of tubes, for it is very simple.

The mutual-conductance test, however, gives a direct measure of the values of the

tube. It is to be understood, of course, that as between different types of tubes, one with a lower conductance may be better suited to certain purposes. (See Fig. 2, showing the average mutual conductance of the various tube types, under the customary combinations of plate and grid voltages.) The "high-mu" and the screen-grid tubes, with their very high amplification factor and their low plate current, have, consequently, a very low mutual conductance. They are, however, satisfactory in the special circuits designed for them. On the other hand, the general-purpose tubes, and especially the '01A and the '27, may be used in any position where a large output current is not demanded; and it will be noted that the A. C. '24 ranks much higher than the '22.

The power tubes have the highest mutual conductance, because their plate resistance is very low; they may be used efficiently (speaking from an engineering standpoint only) in other positions than the last audio stage. Where cost is an object, however, they do not commend themselves to the set designer. It is interesting to note that in other countries, where electric set operation is comparatively rare, and battery consumption an important matter, tubes are designed for specially low current consumption—in other words, high mutual conductance. We find, for instance, the British H1.210 with a filament current of 0.1 ampere at 2 volts, and a plate current of 3.2 milliamperes at 150 volts with 1½-volt grid bias. This tube, with amplification factor of 20 and plate resistance of 23,000 ohms, has a mutual conductance of 870; which may be compared with the 200 of the American '40 type, or the 800 of the '01A type with its lower amplification. In comparison, the dry-cell tubes first used in American commercial sets are strikingly low in mutual conductance.

However, as between tubes of the same type, the mutual conductance increases with the plate current; and, therefore, a high "Gm" reading of a tube indicates that its filament emission is very good. The mutual conductance of a tube, it will be remembered, is the ratio of the amplification-factor to the plate resistance. (The amplification factor is conveniently first multiplied by one million, to obtain the rating in micromhos instead of mhos.) If either of these two values is abnormal, the mutual-conductance reading will show that something is wrong. Any misplacement of the tube, a high leakage-current, will all be shown in a mutual-conductance test.

It remains only to locate a simple method for measuring this value, in order to have an ideal tube tester. One such device, which

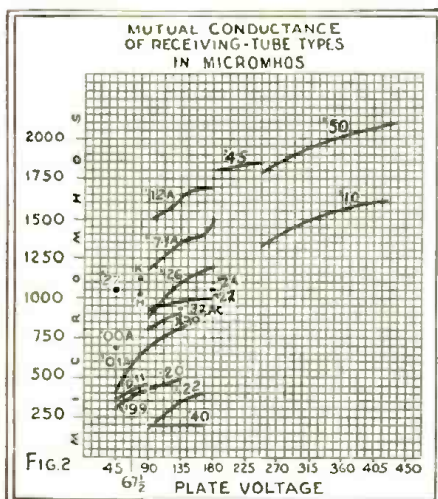

FIG. 2

*In rating a tube's value by its mutual conductance, its type must be considered. Here are average values for standard tubes at normal operating voltages.*

was developed by E. V. Appleton and has been published several times in different books, is described here. Fig. 1 shows the arrangement. When the key K is closed, the potential difference applied between the filament and grid equals  $I'R$ , where  $I'$  is the current in  $R$ . This change of grid potential causes a change of plate current equal to

$$\frac{I}{I'R} \text{ (approximately.)}$$

The currents  $I$  and  $I'$  flow through the galvanometer MA in opposite directions and, if  $R$  is adjusted until the galvanometer reading shows no change, then

$$I = I'R$$

or, in other words,

$$\frac{I}{E_g} = \frac{I}{R}$$

The plate circuit does not contain any external resistance except that of the galvanometer, which is small and can be neglected; the tube's internal plate resistance

is  $R_p$ . When the grid potential is small, it may be stated that

$$\frac{I}{E_g} = \frac{\text{"Mu"}}{R_p}$$

and, since,

$$\frac{I}{E_g} = \frac{I}{R}$$

then

$$\frac{\text{"Mu"}}{R_p} = \frac{1}{R}$$

The value  $\text{"Mu"}/R_p$  is the mutual conductance. Then, if we have a calibrated resistor for  $R$ , it is a simple matter to obtain the correct value of the mutual conductance.

The galvanometer may be a low-reading milliammeter with a full-scale deflection of about 0.10. The grid battery should be about 4½ volts, and the plate and filament batteries should be proper for the tube under test. For  $R$ , the experimenter may either calibrate a resistor or obtain one calibrated by a precision-instrument company.

If only an approximate value is desired,

a variable resistor of good make should be obtained, and a scale made to suit the position of the pointer. (By this we mean that the full resistance may be assumed to be that of the instrument's rating; then one half of the resistance winding will give half the resistance; one quarter of the winding, a quarter of the resistance, etc.) By measuring a number of tubes in this way, the correct point on the scale for a good tube will soon be found; and we will then have a direct-reading tube tester and mutual-conductance bridge.

### Manual Testing

In quantity production of receiving tubes, it is necessary to use some fast but sure method of rejecting those tubes which are defective and passing the good tubes on to the packing department. (We will later discuss the method of making tubes more thoroughly.) Four or five years ago, when quantity production of vacuum tubes was just commencing on a large scale, the general procedure was to check each tube manually, at the maximum rate of 225 per hour,

(Continued on page 346)

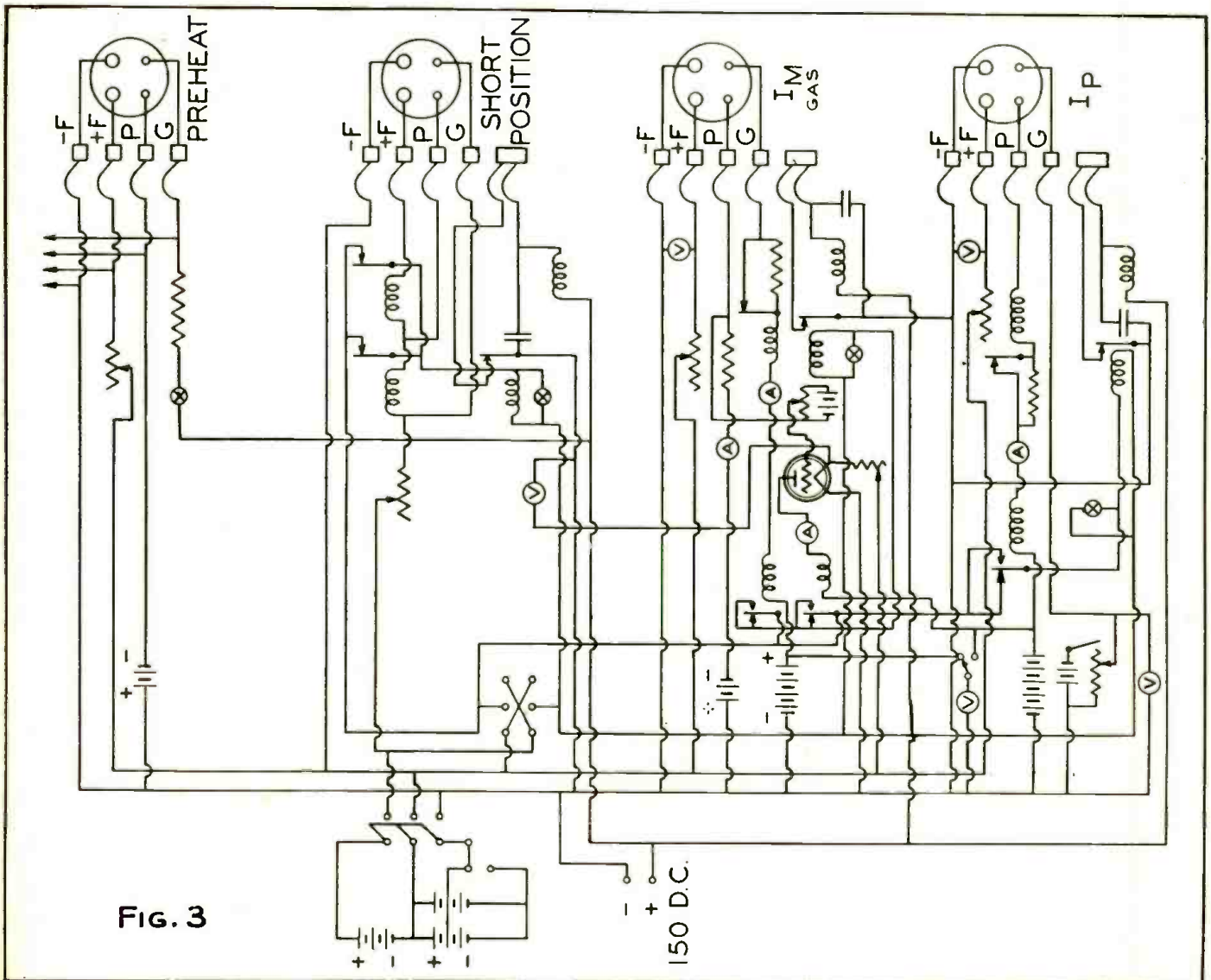
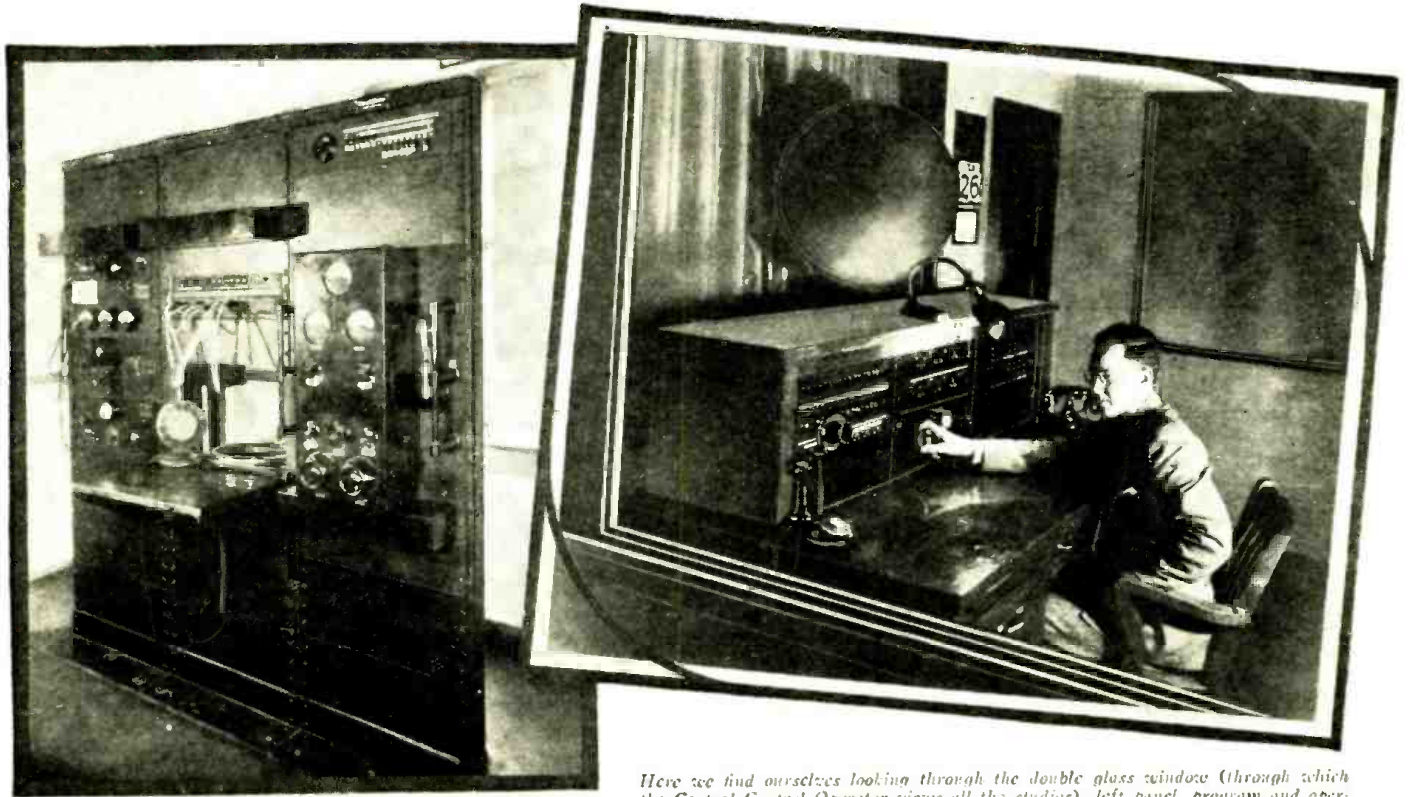

FIG. 3

Not only does the circuit above look complicated, but it is! It is that of a large testing machine which tube makers use to sort out defective tubes on completion of the processes of manufacture. A great many mechanical features are incorporated in the design, but cannot be shown here; the relays (here shown as meters) close other circuits which work the ejectors that throw out all tubes whose test readings depart from the standard too much, either above or below the limits of tolerance.



Speech input equipment in the Operator's Control Room of (Radio) "Station KNX, Hollywood, California;" note paratropie affair enabling operator to announce and change records at the same time.

Here we find ourselves looking through the double glass window (through which the Central Control Operator views all the studios), left panel, program and operators' remote-control circuits; center, mixing panel; right, local switching—in duplicate with announcer's control in adjacent room. The reproducer is "monitoring" KNX, via a superheterodyne.

## From Microphone to Modulator

Being an account of the equipment used and the technical routine followed in a typical, modern broadcast station

By C. STERLING GLEASON

**M**ANY reams are written on various phases of radio broadcasting, particularly on subjects pertaining to personal traits of microphone favorites and the exact shade of a popular announcer's hair; yet comparatively little is said regarding the work of the technicians who, being generally of a retiring disposition and only too glad to carry on their work behind doors marked *No Admittance*, nevertheless are primarily responsible for the clock-like smoothness which characterizes the better radio program of today. Many columns of copy are prepared in explanation of what the wild wireless waves are saying; yet far more interesting, at least to those of the technical persuasion, is the story of the experiences of these waves from the time they are struck into life at the microphone to the time they are impressed upon the carrier at the transmitter.

### Radio KNX

The technical excellence of modern broadcasting methods is impressive, and we too were duly impressed when we recently visited the control rooms of KNX, where a new Western Electric control panel of the 50,000-watt type has been installed. The station

itself is located nine miles away (in the San Fernando Valley, safely away from city congestion, with its accompanying attenuation of signal) and is linked by private telephone line with the studio on the Paramount Pictures' lot at Hollywood.

We find no one in the announcer's room, but a small desk lamp burns hospitably on the table at which the announcer customarily sits. There is little impressively technical equipment in sight, and the room seems much like a study; save that upon the table stands a single small cabinet, whose sloping panel is studded with a dozen or so *key switches* and a double row of black push-buttons paired with red *pilot lights*.

We are puzzled by the absence of the ubiquitous *microphone*, but the mystery soon solves itself when the missing instrument is discovered in the shape of what we had taken for a small mantel clock. A chronometer gleams in nautical brasswork with its mahogany case. Above the desk is suspended a large cone loud speaker—silent, of course, when the announcer's "mike" is cut in—and at the right, the trusty phonograph with its tone-arm *pickup* stands ready to fill up unforeseen gaps in program routine. A desk telephone of the monophone

type, universally recognized by motion picture fans as being as indigenous to Hollywood as Kliegts and private swimming pools, lends a last Ritzy air of distinction.

### Inter-Studio Networks

From his swivel chair, the announcer commands a view of all six studios, which are grouped about the two control rooms and are plainly visible through double plate-glass windows. Since the program comes to him through his loud speaker, and since he has virtually a public-address system at his hand, he can communicate with the artists just as effectively as if he were in the same room—a decided convenience when orchestral numbers from the largest studio are to be alternated with numbers from other rooms.

In the upper left hand corner of the control cabinet is a small green pilot lamp which, we gather, burns when the announcer is on the air. At present, however, it is dark, and we assume that announcements are being made elsewhere, since Mr. Naylor Rogers, manager of KNX and our genial guide, has already told us that the station is on the air daily from 6:45 A.M. to 1:00 A.M. the following morning.



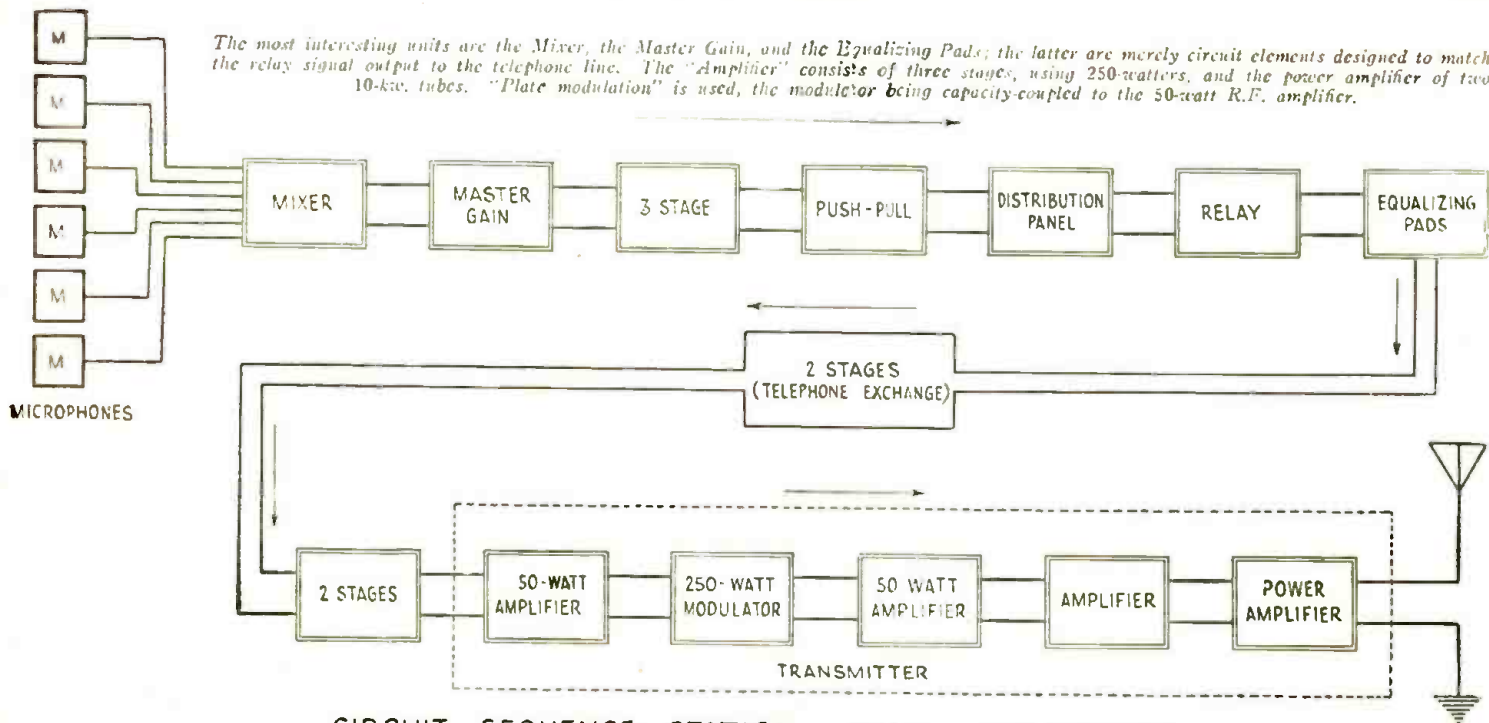

CIRCUIT SEQUENCE, STATION KNX, HOLLYWOOD

We pass through the door into the adjacent room and come upon what is plainly the center of technical activity. It is the operator's control room, where are found the speech amplifiers and the switchboards providing means of supervision over every foot of wire in the whole installation. From here radiate the extension lines over which are brought outside programs and field events, and here originate the private-program circuits linking studio and station by remote control.

Talking loops for communication between technicians parallel all program lines, and all these circuits converge upon the single massive desk where presides the single control operator. He, too, has a view of the

six studios which accommodate various types of program, and thus is constantly in touch with what is going on everywhere in the studio.

**A Change-Over**

At the present instant a bright red pilot light gleams from the upper left-hand corner of the control panel, signifying that a program is coming in over an outside extension line. Beside it, its green twin indicates that the parallel talking loop of the operators is in working order.

The sound of an orchestra is heard from the loud speaker on the wall. The largest studio used for orchestra numbers, is deserted. In reply to our unspoken question,

the operator answers: "It's coming from the Spillmore Ballroom."

He throws the black key switch which is companion to the green pilot, and lifts the receiver of the telephone to his ear. "How many more?" he asks of the "field operator," and back over the talking loop comes the information that this is the last uptown number.

"Wait a minute and you'll see this studio go on the air."

At this juncture an announcer enters, exchanges a few words with our operator, and vanishes into the next room. The music ends. "This," says the loud speaker, "concludes the musical hour broadcast from

*(Continued on page 347)*

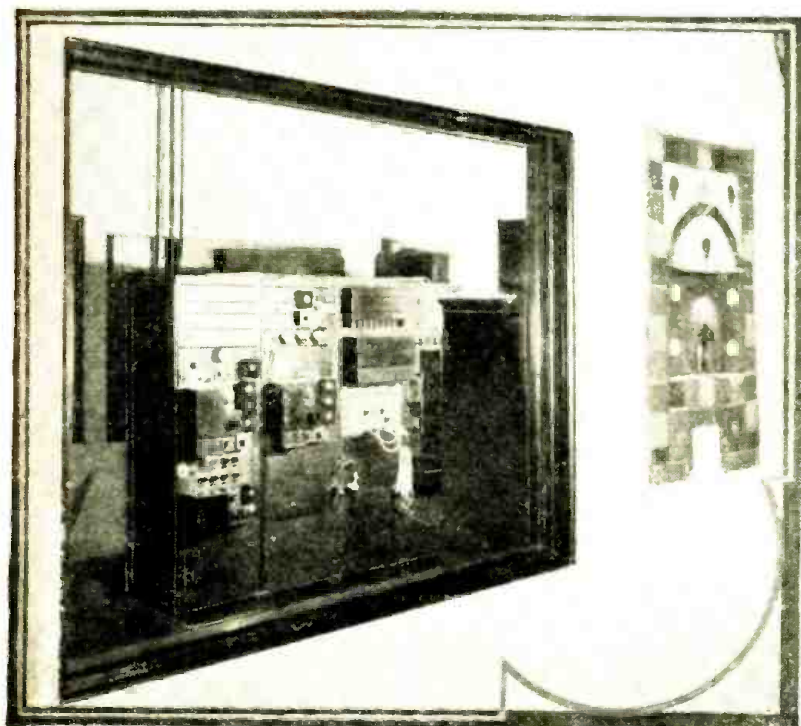

Through the window above, we see the control room; left to right, station-to-line amplifier (the transmitter is nine miles away); power supply; switchboard for quick testing of transmission circuits; and jack board, where remote-control lines terminate.

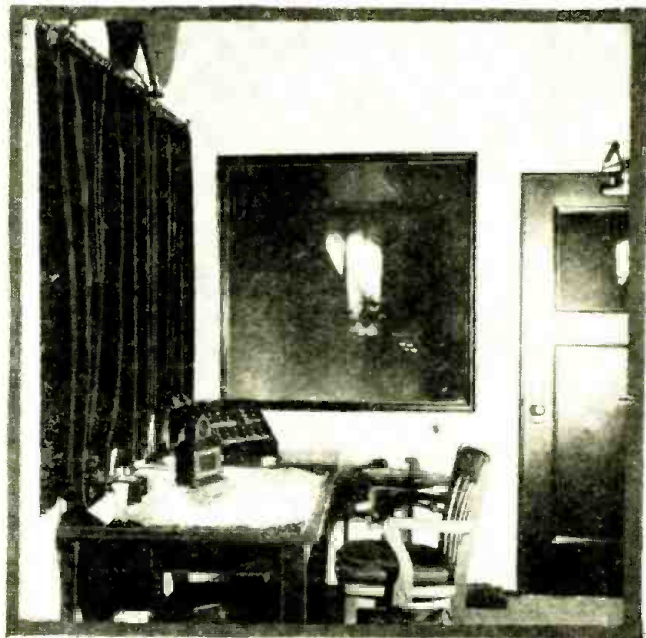

Here we have the microphone relay board in the announcer's booth; here the microphone control may be switched to studios or remote controls by pressing buttons; another button cuts the station off the air, in emergencies. Through the windows the announcer views the studios and the operator's control room illustrated on the opposite page. The clock-like device is a new type of microphone.

# Making Low-Loss Coils on a Celluloid Base

*The Constructor who "Winds His Own" will find the method described here worth the trouble of preparing the simple winding machine described. Efficient and attractive windings result from its use.*

By C. W. TECK

**T**HE solenoid is the best possible coil—how often have we heard that pronouncement? It took quite a long time for this fact to become recognized; but as the latest practice shows, it is generally admitted, though only after manufacturers and amateurs have run the entire gamut of fantastic coil forms and designs. But, when this conclusion was definitely reached, designers rushed to another extreme, and the craze for extremely small coils has prevailed quite as aggressively. Some manufacturers have special reasons for using coils of this type, but beyond this there is no very compelling cause for their general adoption.

Necessarily, such coils must be wound with wire that will allow the greatest number of turns to the inch that is compatible with good insulation. Enamelled wire has this qualification; but, for a radio-frequency conductor, it has the drawback that it is surrounded by a dielectric; so thin that, when no other spacing is used, the coil has an excessive self-capacity and consequently a short tuning range. Sometimes, a thread is cut in the tube used as a coil form, and the wire placed in this; but as a rule, other means are employed, such as under-cutting the tubes and winding the wire in the hollows. This method left the winding free to slip and, after repeated heating and cooling (from the normal temperature variations of the coil in a receiving set) had loosened the turns, the tuning of the set was affected. As another expedient, a heavy coating of

varnish was used to keep closely-wound coils in condition.

These coils, because of the shortcomings cited, have the disadvantages of high radio-frequency resistance and large electrical losses; but they served the purpose of those who were carried away by the craze for compactness and make-shift stabilization.

## The Ideal Coil

Like a great many other things in real life, the ideal coil is unattainable; but there is almost always a practicable compromise available to us. We know what the ideal coil would be—one of silver wire, with no insulating material whatever around it, but yet, untarnishable; held rigidly in a coil, yet without a form. That should be a perfect coil.

There is a way of approaching this desired construction as nearly as possible, with rigid spacing, yet extreme lightness of the form, with a minimum of harmful insulations. This article is intended to show the right way of doing this; because there is another method not so good. Care must be used; but the experimenter will have a valuable asset in his laboratory equipment, always ready and serviceable when a new wrinkle comes along to arouse his activity.

The coils we describe here are mounted on celluloid, because this material is a light one, not affected by moisture, and it can be made easily to keep the individual turns spaced accurately. If they are so wound that they are not buried in the celluloid, and not "doped up," they will have the lowest

losses and the lowest self-capacity possible; and be rigid (*an absolutely necessary condition for successful "gang" tuning*).

## Winding Machinery

No makeshift equipment can be used in the production of suitable coils. For instance, if we wind the coils on a solid form with layers of paper under the celluloid (a method often used with the idea that the complete coil may be slid off intact) we shall be rewarded with disappointment. The handling of the coil will spoil all our efforts. We must proceed in the right way.

To assure the successful working out of our plans, we must get a split metal tube, two inches in diameter and about a foot long (Fig. 1). This is the form or mandrel upon which the coil is to be wound. The diameter given will be found the most convenient for a radio-frequency coil. Besides, it may be convenient to obtain a piece of metal of this size from an old metal bedstead; such tubing is often seen lying about the streets, or in a junk shop, where it is stripped of a light brass sheathing. If such a tube cannot be obtained in this manner a steel tube (having a No. 32 wall) should be purchased and carefully split down its entire length with a hacksaw; carefully squeezed in a vise and bound with iron wire to close up the widened cut (because the steel has a spring that will open up the tube too much); and subjected to a low red heat.

Inside this tube, when cooled, there is then forced a hardwood stick (Fig. 2) of suitable size (or better, such a stick covered with a metal tube), whose purpose is to expand the softened tube not more than  $1/32$  inch. Beyond this, the pressure needed would be too great to permit the spreading stick to be removed readily. In this way, however, the split tube can be compressed sufficiently, after the removal of the spreader, to take off the coil without injury.

It is assumed the reader has now a definite idea of how the winding form should look (Fig. 3) and is ready to tackle the spacing mechanism. This is simpler than it may appear, for it is nothing like the completed devices used by commercial winders; yet if it is made and operated correctly, the spacing of turns will be found in every way equal to that found in commercial coils.

This device is nothing more complicated than a thin steel wire to which a light weight is attached, and which is allowed to hang over the winding form (Fig. 4); so that it touches the magnet wire at the point where the latter is being wound on the form, and separates it from the previous turn. As

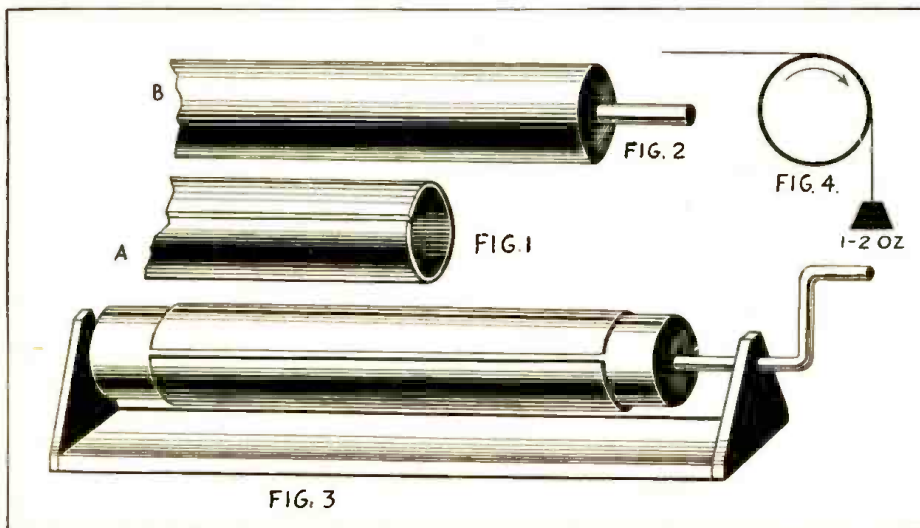

The tube form required for celluloid-base coils is arranged as shown. Fig. 1 is a split metal tube, over which the celluloid is tightened; Fig. 2 the "spreading stick," taken out to permit removal of the coils, and used alone to wind primaries of slightly smaller diameter. Fig. 3 is the complete assembly; and Fig. 4 the simple spacing arrangement which produces low-loss coils.

January, 1930

and the  
and the  
side the  
electric  
is free to  
stands  
but keep  
while the  
5A gives a  
spacer and  
of magnet

the coil turns increase the st  
weight move at the  
only caution to be  
magnet wire  
power is

**Feed**

regulating the  
that an even  
the coil must be  
done some por-  
ze the form less  
ill be loose. Care  
sheet will do more

tightly-wound coils than any other  
single factor.

But the arrangement for retarding the magnet wire is an essential part of the mechanism, and must be constructed before we proceed further with the winding. A study of Fig. 5 will show what this is like. A grooved wheel *A* is forced over a metal tube *B* so that they turn on a rod *C*. A cord holding a weight *D* is set in the groove of the wheel and firmly anchored somewhere. The spool of magnet wire, *E*, is slipped over the tube, and a wedge inserted to make it turn only with the wheel and tube. It is obvious that increasing the weight *D* has a braking or retarding effect on the spool, while the wire is being wound on the coil form. This constitutes the braking device, and is essential to any type of coil winding.

It will be seen that the spacer wire and weight are attached to the tube *B* at *F*. The latter is a ring, loose so that the tube may turn in it. This method of attaching the spacing wire near the spool is to keep the two wires as nearly parallel as possible, which helps to hold the spacer in the right course. It will be noticed also that the retarding device is free to move along the rod; so that the spool may move as the coil grows in length.

**Making a Coil**

Let us suppose we have the winding machine completed, and desire to make a set of coils for a receiver using .00035-mf. condensers. We require on each coil 74 turns of No. 24 silk-covered wire, spaced with a No. 38 steel wire. All three coils are to be wound as one long coil, and later cut into lengths with the requisite number of turns in each.

The first step is to procure a sheet of celluloid nearly as long as the form or mandrel *M*, and overlapping by less than half an inch when wrapped around the form. Celluloid .015-inch thick can be obtained at auto supply houses; but .010 thickness is preferable. A sheet of wrapping paper about the size of the celluloid is wrapped about the mandrel, and over this the celluloid is put. Rubber bands are used to hold both tightly. After they are placed on the mandrel, along with the rubber bands, the mandrel should be rotated, while the hand retards it by gripping the celluloid at places along its length. This causes the paper and celluloid to grip the form tightly; and when this can be done no longer without

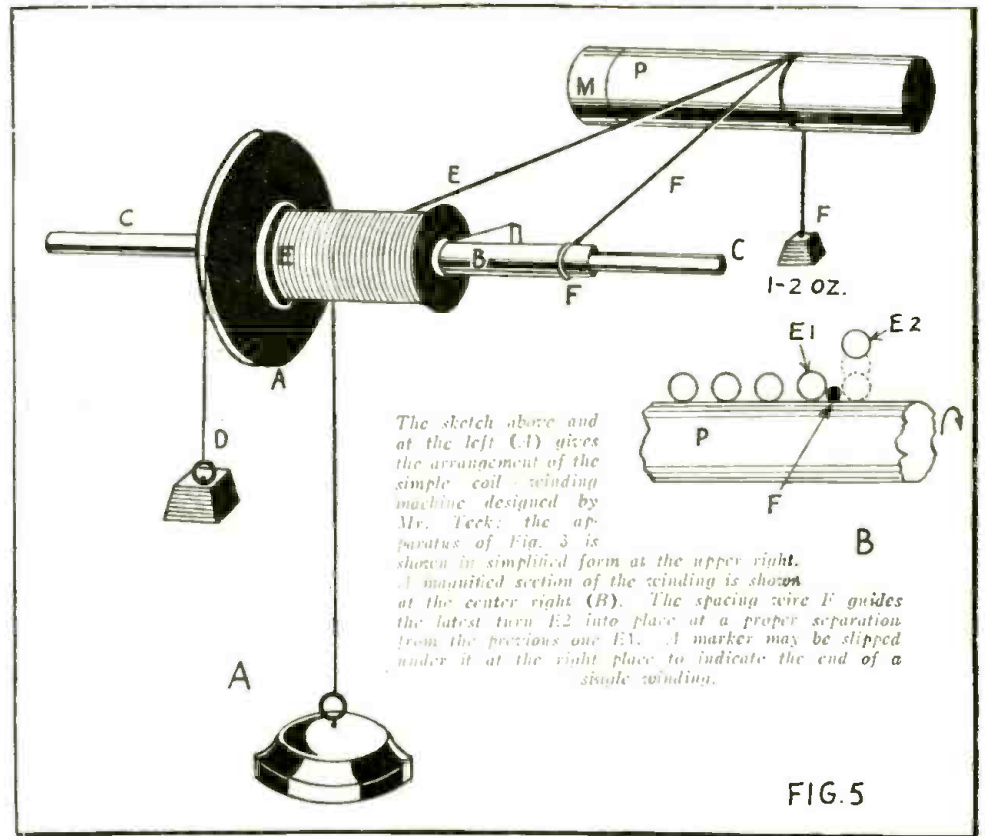

FIG. 5

stopping the mandrel, the fit may be regarded as tight.

To begin winding, anchor the magnet wire in some way to the mandrel, and then take up a position in front of the machine, wind on a few turns, and with the free hand take a piece of thin wire or thread and place it under the wire at the point where it is about to touch the celluloid. (See Fig. 5B). This is the starting point for coil No. 1. Endeavor to keep the lead from the spool parallel with the turns on the form, and continue till 76 turns are wound on in this manner. Then insert a loop of wire or thread; and so on at every 76th turn. Now, without releasing this form, end the spool by winding on a turn or two more as the case may be. This makes one long coil of wire, with loops showing where the individual coils are separated and later to be cut.

**Treating the Coils**

The next step is to apply the solvent ("ethyl acetate") with a fine hair brush—not too large, or it will waste the solvent, nor too small, as the work will then take too long. Apply the brush along the length of the coil; then turn it to a dry portion, and so on. Repeat this operation, taking care that no dry spots are left untouched; but do not drench the coil, as this will soften the celluloid too much and allow the turns to sink into it, producing uneven spacing and an effect akin to doping. Altogether, the coil should be kept moistened about one minute. This is sufficient to make the silk fibres adhere; but should any difficulty be experienced in making the wires stick, a few scraps of celluloid may be dissolved in the ethyl acetate. Another precaution is, do not handle the celluloid or wire with oily or greasy hands. When the solvent is pure, the covering of the wire is not darkened and, even when a small amount of celluloid is dissolved in it, the discoloration will not be noticeable.

The coil should be allowed to dry for about an hour, to give the celluloid time to harden. When this is done, the spreading stick is pushed out of the mandrel, allowing the latter to contract so that it may be pushed out of the coils. The paper is then removed and the operation of cutting the coil begins. A knife having a thin blade and a sharp point is used to dig under the wire where the loop indicates the end of a winding. The wire is lifted clear of the celluloid and cut, and half a turn is peeled off; first with one cut end and then with the other. The two half-turns removed leave a mark, around which the point of the knife is passed, by rolling the coil on the table. When the severed portion is trimmed by paring off the fringe caused by the cutting, the other half turn is peeled off, and so on both ends; thus forming the secondary leads for a coil with 74 secondary turns. All this should be done immediately after the coil has been removed from the mandrel, after the time required for drying.

**Making Primaries**

The primary is wound upon the spreading stick, or inner tube, over a layer of paper, in somewhat the same manner. Larger spacing wire is used, and the pressure on the supply spool is reduced; so that the coil can be easily removed. Since the amount of primary winding is small, this is not difficult. All counting of the turns is done when cutting.

To mount the primary inside the secondary, strips of celluloid are built up to the proper thickness to give an even spacing all around the coil between the primary and secondary. To do this, a cement is made by dissolving celluloid scraps in the ethyl acetate until it assumes a syrupy consistency; it is then applied to the celluloid.

January, 1930



# RADIO CRAFT KINKS

The two readers of RADIO-CRAFT who send in the greatest number of ingenious Kinks each month will be awarded, a copy of "The Radio Amateur's Handbook," a work well known for its value; in addition to the space rates paid all articles printed.

## D.C. FROM YOUR AUTO

By Joseph Riley

**A** RECENT news item stated that a young man interested in radio had married a young woman also interested in radio. They made a special five-tube set, for use during their honeymoon, to be operated by the storage "A" battery in the automobile they owned.

Anyone can operate their receiver this way by following the idea illustrated in Fig. 1. Any burnt-out "bayonet-base" lamp may be used. The glass part is broken out and two leads are soldered to the contact points. There are two types of base: single-contact and double-contact; use one which properly fits the particular outlet you want to take the six-volt supply from. *Caution:* Examine one of the auto lamps and make certain that the D.C. supply is not 12 volts.

A wooden handle is fastened to the lamp shell; this makes it easy to remove the current tap and replace the lamp. It is usually most convenient to tap the current at the instrument board.

The amount of current consumed by the average five-tube set in an hour is about one and one-half amperes; the automobile lamps probably consume three to ten amperes. So, the comparison indicates, there is no objection on the score of undue battery drain. In fact, the starting motor will probably draw as high as 300 amperes (instantaneous value) for the few seconds it is on during starting.

If a two-color cord is used for connecting, it will be easy to distinguish "A" positive from "A" negative, by using a red lead

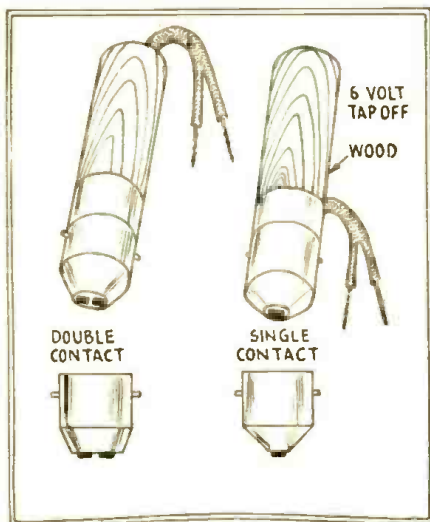

Fig. 1

A simple tap to the automobile storage battery will operate a receiver efficiently.

for the former and a black wire for the latter.

Of course, it is necessary to have the right connection when the plug is made up; but, as the sockets will probably all be connected the same way, the "A" polarities to the set will not be reversed if another socket should be tapped at another time. Usually, the shell of the single-contact base will be negative and the contact positive; a simple test for the double-contact base is to connect the plug "A" leads to the set. If it works, the connections are correct; if it doesn't, the "A" connections are reversed.

A clever arrangement would be to install a set of "B" batteries in the car and wire them to an outlet on the instrument board, to be tapped with another plug. Be sure these "B" voltages are by-passed inside the set.

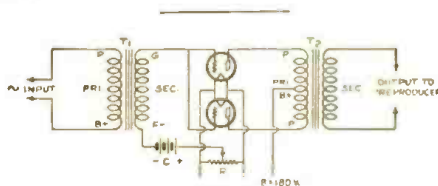

Fig. 2

This parallel input and push-pull output is economical, and worked well for its constructor.

## A SEMI-PUSH-PULL A.F. STAGE

By R. Wm. Tanner

**R**ECENTLY a stage of 71-A push-pull audio amplification was needed for one of the writer's experimental receivers. A look through the "junk box" proved that no center tapped input transformer was available, only a regular transformer, T1, and an output push-pull transformer, T2. Paralleling the tubes would not do; this had previously been tried, with very poor results, under the existing conditions.

A little constructive thinking on the subject resulted in the "hybrid" circuit of Fig. 2. The plates are connected in the conventional push-pull manner, but the grids are in parallel.

This circuit seems to give practically the same results as the regular push-pull stage when considered from the standpoint of undistorted output and minimum A.C. hum; it has the added advantage that a lower input voltage from the preceding stage is required.

## A NOVEL COUPLING IDEA

By Alan Hamilton

**T**HE problem of adding an antenna winding to a single-winding short-wave coil of the "tube-base" type has been "solved" by most amateurs, who do without this coil;

with consequent loss of the qualities obtained by this arrangement.

Another solution of the problem is treated in Fig. 3; a coil, larger than the "tube-base" coil, is mounted slidably on vertical rods, which may be bus bars. The two clips are of the "Palmestock" type and may be loosened from the rods by pressing; the coil thus being easily adjusted to any position. As the experimenter may desire to use this newly-applied coil as a regenerative (tickler) winding instead of an antenna coil, the desirability of easy adjustment is apparent.

The coil when used as a tickler is wired into circuit with an external control of circuit oscillation.

## MEASURING SMALL RESISTORS

By J. A. Umberger

**F**REQUENTLY the experimenter wishes to know the value of a certain resistance. From outward appearance, one cannot distinguish a 50-ohm resistor from a 500-ohm; but here is a simple way to find the approximate value of a resistance. The hookup shown is an improvised bridge circuit composed of parts every experimenter has, namely: a potentiometer, headphones, a battery, and a resistor whose value is known. One should choose a known resistance which he guesses to be as near the unknown value as possible; this will give greater accuracy. For the same reason, choose by guess a potentiometer whose resistance is near the value of the sum of the known and unknown. (By near, is meant something not over three or four times as large; which is close enough for most purposes.)

The procedure is to tap the connection in—  
(Continued on page 350)

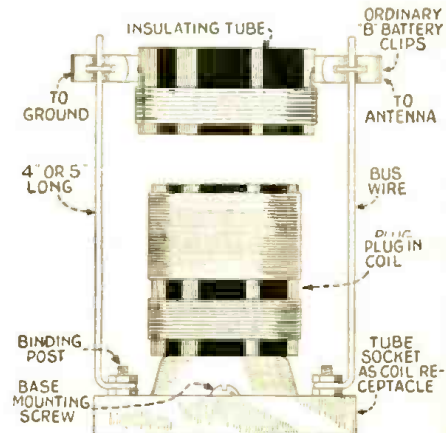

Fig. 3

A tube-base plug-in coil is easily equipped with an adjustable winding in this way.

# How to Make a Wave-Resonance Tuner

*Unknown to the general public, the U. S. Signal Corps Laboratories under the able direction of Major William E. Blair have been developing applications of the principle of Wave-Resonance Tuning. The results are chronicled in this article.*

By S. R. WINTERS

Washington, D. C. Correspondent of RADIO-CRAFT

**A** TUBE-LIKE coil of wire, mounted over a plate of aluminum, is the simple instrument used in the application of the "wave-resonance" method of tuning radio transmitting and receiving sets. Not only has Dr. Louis Cohen, an eminent consulting engineer, developed a mathematical formula but the

which is movable, up and down; and thereby signals from different broadcast stations are tuned in. This metal plate serves the same function as our widely-used variable condensers: but, instead of rotating around an axis, it has a vertical movement.

The coil of wire and metal plate are mounted between two upright insulating supports: the latter have a foot, or base support, in the form of another piece which is short and narrow. One of the upright supports contains the terminals connecting the wave-conductor to the antenna and receiving set; whereas the other upright has a slight extension through which is passed a long screw, with a dial or knob on top. This screw is employed to vary the distance between the coil of wire and the aluminum plate; and, thus, to select signals.

### Principle of the Resonance Coil

The simplest explanation of the theory of circuit tuning by "wave resonance" is that of capturing a "stationary radio wave" on a wire and then picking out the resonant points. However, a more elaborate and strictly scientific definition of "wave resonance" is advanced. "It is," to quote Dr. Cohen, who formulated the mathematical theory, "the condition that obtains when a conductor of distributed inductance and capacity is subjected to electrical oscillations, and either the length of the conductor, or the inductance and capacity per unit length of conductor, is properly adjusted in relation to the frequency of the oscillations. If an electric impulse is impressed on a conductor of distributed inductance and capacity, which is open at the far end, the impulse travels along the conductor and, on reaching the open end, it is reflected there, returning at the same velocity. If, at the time of its reaching the starting point, an impulse of opposite direction is sent into the conductor, the second impulse adds to the first.

"If, therefore, alternate impulses are impressed on a conductor and so timed that the interval between them is the time required for the impulse to travel to and fro on the conductor, a high voltage or current

(Continued on page 348)

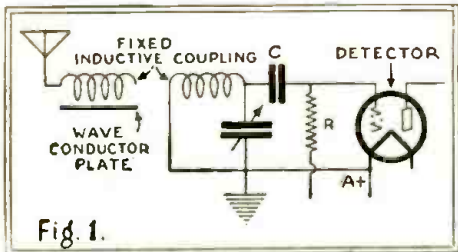

Fig. 1.

With a strong signal, the wave-resonance tuner, indicated by the special symbol at the left, may be coupled inductively to the grid circuit of a detector effectively. This circuit is selective.

system has been adapted to various practical uses by the Signal Corps Laboratories of the War Department. Commercial receivers for broadcast reception have been utilized in connection with this method and Major William E. Blair, in charge of the research and engineering division, has applied it to the operation from one antenna of three transmitting sets on different frequencies.

While the mathematical formula of wave-resonance tuning encompasses the requirements for short-wave transmission and reception, the Signal Corps Laboratories worked on the design and construction of coils covering the wave spectrum assigned to broadcasting. An independent investigator has made a tuner with a 4.5-to-1 tuning range.

### Design of a Wave-Resonance Tuner

For example, one of the wave-conductors—covering a wavelength range of 300 to 550 meters—includes a coil 8 inches long and 2 inches in diameter, containing 400 turns of very fine cotton-covered wire. The completed coil takes the form and characteristics of a solenoid, and may be wound readily by any experimenter. (The coil pictured in Fig. A, at the right, was designed for a band partly below the broadcast spectrum, and consists of only 225 turns of wire. By following the directions in the text, however, operation in the broadcast band will be obtained.) Immediately underneath this coil of wire is adjusted a thin plate of aluminum—8 inches long and 4 inches wide—

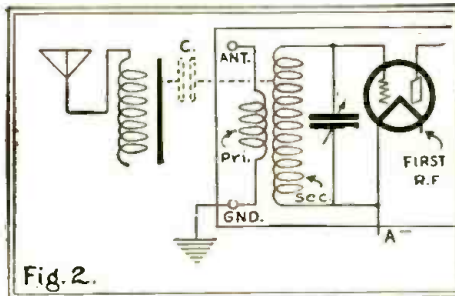
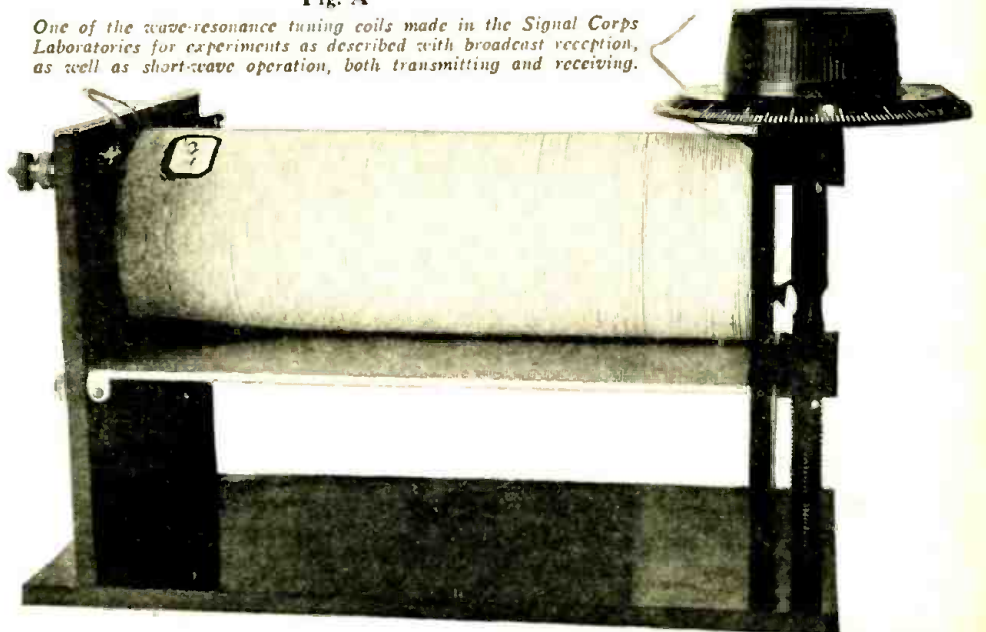

Fig. 2.

Capacitive coupling of the wave-resonance tuner, in place of the usual antenna lead, to the first radio-frequency stage.

Fig. A

One of the wave-resonance tuning coils made in the Signal Corps Laboratories for experiments as described with broadcast reception, as well as short-wave operation, both transmitting and receiving.



# The Electrostatic "Radiophon"

*A new device in which the listener forms a part of the reproducing mechanism, invented for the use of the deaf, applies an old principle in a novel way*

By DR. GUSTAV EICHHORN  
*Radio Technical Institute, Zurich, Switzerland*

**E**XPERIMENTS in enabling the deaf to hear radio, as well as certain theoretical studies, led the writer to design the instrument which he has patented and made known as the "Radiophon." (Unfortunately, because of the widespread use of this word to describe other apparatus, it is not suitably distinctive.)

Its operation depends upon connecting the person of the listener into the output circuit of an audio amplifier, where the phones or reproducer would ordinarily be located. One terminal of the circuit is attached to an electrode taken in the hand, or some other electrical connection to the body is made. The other is connected to a metallized layer which has been coated upon a dielectric (preferably a so-called semiconductor, such as parchment, very thin leather, parchment paper, etc.); and the non-metallized side of this diaphragm is held, by the aid of an insulating handle, against the ear. No special polarity is required; though in practice, at times, better results may be had by reversing connections.

### Construction of the "Radiophon"

The instrument, illustrated in Fig. A, is shown in cross-section in Fig. 1; while a front view of the handle is given in Fig. 2.

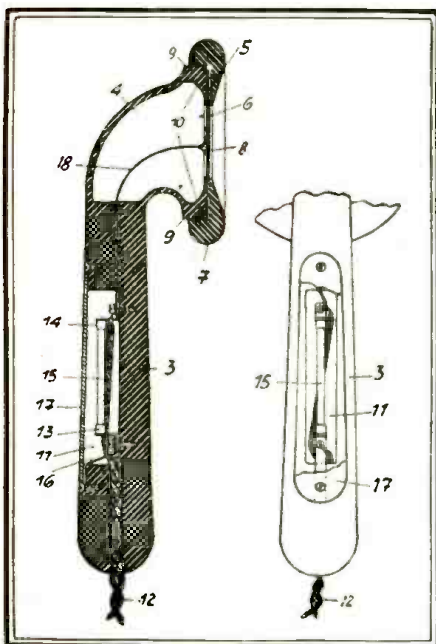

Fig. 1 (left) Fig. 2 (right)  
Side and front cross-sections of the "Radiophon." The principal parts are named in the text.

The handle (3) encloses a hollow space (4) like that of the earpiece of an European telephone, but this is not essential. Over this recess is placed the "dielectric membrane," its metallized side (5) on the inside.

The double wire (12) is led into an opening in the handle, where the high-resistor (15) is connected across it. One output lead is connected also to the metal strip (17), which covers these connections and makes contact with the hand of the listener, who is holding the device. The wire (18) connects the other output lead to the metallized side of the dielectric diaphragm (5-6).

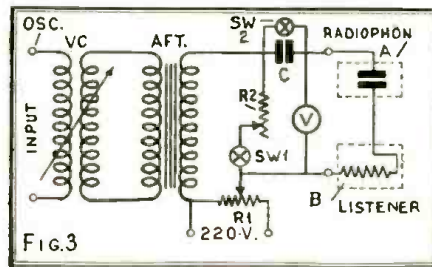

FIG. 3  
An experimental circuit, with controls designed to test the characteristics of the "Radiophon." To be exact, the listener is one plate of the condenser, as well as a resistor.

The resistor (of say 100,000 ohms) eliminates unsteadiness or breaking of speech and music, otherwise occasionally noted. The plate voltage to be employed for best results depends on the tube; but at least 70 to 100 volts should be used.

### Principle of Indirect Hearing

The "Radiophon" is held with the unmetallized side of the dielectric in contact with the ear; the dryer the diaphragm, the better (as a matter of fact, the dielectric might be dispensed with, and the metallic membrane applied directly to the ear; but the sensation would not be particularly pleasant). For this reason, the diaphragm, if absorbent, should be varnished to protect it from moisture.

Audibility is strongest when the instrument is held very close to the ear; but the sound is not lost when the instrument is held in contact with other parts of the head, such as the cheek, temples, forehead, or even on top of the head. This indicates a physiological effect communicated directly through the head to the sensitive interior organs of hearing. Thus, even deaf persons whose eardrums no longer function properly, but whose nerve centers are intact, can hear radio.

It is a well-known fact that many such persons use the telephone very well; in this



Fig. A  
One model of the "Radiophon," showing the reproducing surface above the handle.

case the sound vibrations seek a path other than the usual one. So, also, if such a deaf person holds the handle of a tuning fork between his teeth, he hears the sound clearly. The American editor and inventor, Hugo Gernsback, used this principle in his "Oso-phon"; which is an electromagnetic telephone receiver transmitting its powerful vibrations to a projection which the listener holds between his teeth. This, however, is not very comfortable, so that the device has not proven popular.

(The principle embodied in the "Radiophon" was also described by the Editor of RADIO-CRAFT, some four years ago, as an experiment to be performed with a sheet of paper; but was not applied to the production of a perfected instrument, like Dr. Eichhorn's.—Editor.)

### Operating Characteristics

An experimental hook-up of the "Radiophon" is shown in Fig. 3, wherein the A. F. modulated current is fed into the primary of the variocoupler VC, and thence to the primary of the transformer AFT; upon the secondary of which is impressed a direct voltage regulated by the potentiometer R1. Switches permit the throwing of the blocking capacity C or the high resistance R2 into the circuit; and the voltage across the output A-B (and, consequently, the "Radiophon" and its operator) is measured by the electrostatic voltmeter V.

With very weak A.C. voltages, such as operate an ordinary receiving set, the audible effect commences when the D.C. ("polarizing") voltage reaches about 70, and continues to increase to about 150. From thence upwards there is no important increase in volume.

(Continued on page 350)

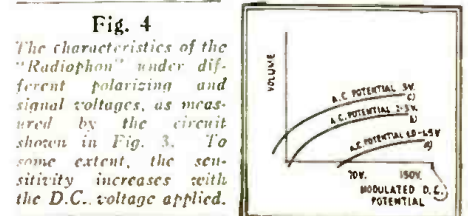

Fig. 4  
The characteristics of the "Radiophon" under different polarizing and signal voltages, as measured by the circuit shown in Fig. 3. To some extent, the sensitivity increases with the D.C. voltage applied.

# The Radio Craftsman's Own Page

*In these columns will be found letters of RADIO-CRAFT readers from every quarter of the globe. Here old friends will renew acquaintances of long standing.*

## SHORT-WAVE "SKEDS"

Editor, RADIO-CRAFT:

I can give some of the information asked for in your last issue. The Mexican station is XDA at Chapultepec on about 15.85 meters. VPD at Suva works on 20.795 and 31.3, and is owned by Amalgamated Wireless of Australasia.

The Siamese do not seem to be working on the schedule given by Mr. Asanachitta and the A. R. R. L.; they are heard here most any day from 1 p. m. on. They work DGW, Nauen, mostly; very little English is used, though they have been heard greeting the United States.

VK2ME on 15.5 meters is working GBX, England, on 18.56 and 24.5; VK3ME has been temporarily discontinued.

The Swedish chain programs are being heard near 50 meters at 11 p. m. The German station working XDA is D111; the same transmitter as DGW, but on 15.02. The Zeesen station is coming in fine on 31.38 and I am informed that this is the station which will be used for the exchange of programs with the N. B. C. Their schedule is now 8-9 a. m. and 2-4:30 p. m.

HKCF at Manizales, Colombia, is on 35 meters. K1NR at Manila, P. I., on 24.5 meters has come through here twice and gives promises of reaching the eastern U. S. fairly well this winter.

Perhaps the most consistent station, at the beginning of November, is VRY, Georgetown, British Guiana, on 43.86, Wednesdays and Sundays. They generally sign off at 9 or 9:15 p. m., not 10:15 as your letter states.

Saigon, Indo-China, will be operating on 18.75 in December; the address is Boite Postale 238, Saigon. G2NM, Caterham, England, is expecting a permit to work on 20 meters soon. NR11, Heredia, Costa Rica, will have 150 watts instead of his former 7½.

K10, Kahulu, Hawaii, sends a verification; they are on 25.68 meters with 1 kw. power; they work telephony with KES 28.80 and KQJ 16.61, Bolinas, Calif.

It may interest some of your readers that there is a Short-Wave Club of short-wave fans in the United States. For information, they may write me.

ARTHUR J. GREEN,  
700 Alpha Street,  
Klondyke, Ohio.

## SUCCESS IS COMPARATIVE

Editor, RADIO-CRAFT:

In your November issue you ask for experiences with short-wave adapters. I have not been successful, but will give you my experiences. I purchased one of the short-wave adapters and gave it a trial, but had poor success. I then took it down, practically, went over all contacts and thoroughly cleaned and tightened them. Then it worked reasonably well.

I am using an RCA "41" with an inside 42-foot aerial of No. 18 rubber-covered wire just stapled to the rafters in the attic, and the usual ground.

I have received on the loud speaker, in the last two weeks, the following:

WND, Deal, N. J. (and Houlton, Maine), working GBS, Rugby, England. Transatlantic phone on several wavelengths; WOO, Deal, N. J., testing with WSCU; W2NK, W2XAD, W2XAF, W2NO, Schenectady; W8NK, W8XAV, Pittsburgh; W2NE, Richmond Hill, N. Y.; W9NF, Downers Grove, Ill.; W9XAA, W9NR, Chicago; W9XAF, Minneapolis; WCK, Detroit Police Department; Radio-Vitus, Paris, calling New York.

I don't know whether this is new or not; but I use over my '27 detector tube a small shield, grounded to the frame of the chassis. I first throw the tube into full oscillation, and then tune in all stations and pass such as show code, or other than phone or broadcasting. I then drop back below oscillation and pick up those stations that are other than code. I like to read about others' achievements.

C. M. McPATRIDGE,  
Moravia, Iowa.

(Some of our readers would like to swap their success for Mr. McPatridge's lack of success.—Editor.)

## HAM DOPE WANTED

Editor, RADIO-CRAFT:

I have built the "Sun" short-wave tuner described in your September issue, and have had very fine results with it. On Sept. 2 I received W2XAF very loud, and on September 3, KPO on 19 meters. I have always received distant "hams."

I think of RADIO-CRAFT as the best magazine that can be had; but I do think it would be much better if you published more short-wave receivers and transmitting dope and diagrams for the hams.

A "near"-in-the-future ham,

JOHN F. SMITH,  
2705 So. Avers Avenue,  
Chicago, Illinois.

(With its enlarged size, RADIO-CRAFT trusts to be able to give every subscriber more of the material that interests him most, personally. We shall welcome all readers' letters—even though it will be impossible to find room for most of them, unless they give information valuable to others—because expressions of preference are what the editor relies upon as a guide when allotting the amount of space to be devoted to each department.—Editor.)

**T**HE letters of encouragement and praise which our readers have been showering on us have been very welcome to the Editors of RADIO-CRAFT, and they take this opportunity of acknowledging the great number to which it has been impossible to reply personally, much as they would have liked to do so. This is YOUR magazine, and it will welcome every letter which expresses a definite wish for a certain line of editorial information.

We trust to make this Craftsman's page the stamping ground of those who like to follow out their own ideas and do something a little different. What have you found out for yourself that will help along other experimenters? Write to the Editor of RADIO-CRAFT and tell your story in your own words.

## A SOURCE OF THRILLS

Editor, RADIO-CRAFT:

Speaking of thrills in short-wave reception, I received one the evening of October 8 that I won't forget very soon.

I am using an improved B-T short-wave receiver, which I constructed myself, and have been getting very good results from it. On this particular evening, mentioned above, I was tuning around on the 25-to-50-meter band, and picked up some phone station calling WOO. These signals came in quite loud and clear and I presently heard the voice say: "This is WBSX calling WOO." I then looked up these call letters and found, to my great surprise, them to be those of the S.S. Leviathan. It was 11:18 p. m. when I picked the ship up, and I was able to understand everything; despite the fact that weather conditions were not good and there was quite a good deal of static. This came in on about 42 meters.

I have been unable, however, to find out where station WOO is located, although I have listened to that station a number of times. Signals from station WOO come in very good, I being able to receive them on loud speaker at any time.

Would appreciate it very much if you would give me this information and oblige.

HOWARD S. HENMAN,  
461 N. 6th St.,  
Chillicothe, Illinois.

(The broadcast station WOO, Philadelphia, was given up more than a year ago, and the call has been assigned to a station erected by the A. T. & T. Co. at Deal, N. J. It is a 20-kw. transmitter operating on 3,124, 4,116, 6,515 and 8,630-ke., 20-kw.—Editor.)

## INFORMATION TO EXCHANGE

Editor, RADIO-CRAFT:

I am a short-wave fan with three years' experience. I would like to communicate with other S-W enthusiasts, and especially with those who have built the "Space-Charge Autodyne." I should like to hear of their results, as I contemplate building one of those receivers. With my present set, which is an improvement on the "Junk-Box," I have heard G5SW, FW3, PCK, PHH, PCL, W6XX, CJRX, DHC, NR11, PCJ and PLF.

CHARLES ZELAITES,  
P. O. Box 165,  
Lincoln, N. H.

Editor, RADIO-CRAFT:

I am a double subscriber (i.e., two copies for scrap-book filing) to RADIO-CRAFT; it fills a need for the unattached, sideline builders and experimenters not found in other publications. We spend a lot of money for parts, and we are sorely in need of such a magazine. Mr. Gernsback, we salute you.

I am building Mr. Fitch's band selector and, since Acme transformers are hard to obtain here, I tried rolling my own. Results were unsatisfactory. I want to get in touch with someone who has tried the choke-and-leak or "T. A. T." system; perhaps we may benefit by exchange of ideas. Mr. Fitch's "1930" electric, battery-operated, should make an excellent car set. I invite experimenters to write or phone me.

RAYMOND CORDER,  
"Skyline 9978,"  
362½ Eleventh Ave.,  
San Francisco, Calif.

## HOME-WOUND COILS

Editor, RADIO-CRAFT:

Your magazine is apparently making itself felt in the radio profession. Each month's issue seems better than ever. Congratulations!

I was interested in Mr. Sutton's article on three-circuit tuners, in the August issue; his last sentence gives much room for thought. Why is it that much of the high-priced and widely-advertised apparatus fails miserably on actual test, compared with crudely-designed and home-made contraptions?

Being in need of a good all-round three-circuit tuner, for use in small sets for battery operation in a rural district, I tried several well-known makes. In each case the results were disappointing. In disgust, I decided to wind my own coils, using any old cardboard tube, having no regard for low-loss construction, and (I must confess) being none too fussy as to general appearance. The results, however, were most encouraging and far ahead of any of the commercial tuners for which so much is claimed by the manufacturers.

My chief trouble with the latter had been lack of sensitivity, which I think I overcame in my own coils by increasing the amount of wire in primary and ticklers.

I have always had the greatest respect for the output of the laboratory, being by no means an advocate of rule-of-thumb methods against scientific research; but my confidence has been rudely shaken by these comparisons. Are the advantages claimed for low-loss construction, space-winding, air dielectrics, etc., grossly overrated after all?

SYDNEY E. THORNE,  
Thorne & Clinton, Radioticians,  
Springfield, N. B., Canada.

(The commercial coil, like the commercial receiver, has been designed with the paramount idea of meeting conditions in cities and towns, where there is radio congestion and sensitivity is a curse, unless accompanied by the highest selectivity. Mr. Thorne's home-built coils would probably be of doubtful utility in Chicago or New York, though far superior for use in his own community.—Editor.)

# INFORMATION BUREAU

**SPECIAL NOTICE TO CORRESPONDENTS:** Ask as many questions as you like, but please observe these rules:

Furnish sufficient information, and draw a careful diagram when needed, to explain your meaning; use only one side of the paper. List each question.  
 Inquiries can be answered by mail only when accompanied by 25 cents (stamps) for each separate question. We cannot furnish blueprints or give comparisons of the merit of commercial products.  
 The reader asking the greatest number of interesting questions, though they may not be all answered in the same issue, will find his name at the head of this department.  
 Highest for the current month: CHAS. F. LANOUILLE with seven interesting questions.

**"LIVE" GROUND LEAD—THE ROYAL SET**

(36) Mr. O. Ingmar Oleson, Ambrose, No. Dakota.

(Q.) What is most likely to be the trouble in an A.C. set, when the 110-volt current passes through the ground wire of the set? Set cannot be used with ground lead. Would a condenser in the ground lead help, and what capacity should it be?

(A.) This unusual phenomenon is probably due to a "ground" between the windings of the power transformer. If this transformer is carefully tested, it will be found that the insulation between windings has broken down. A fixed condenser of 0.25-mf. capacity may be connected in the ground lead; but it is best to have the transformer repaired. Otherwise, the insulation may break down still more, and eventually arc; setting fire to inflammables in the cabinet.

(Q.) What is the schematic circuit of the receiver used in Windsor Castle by King George V? It does not require an aerial.

(A.) The receiver mentioned has been superseded by a later model; the schematic circuit, however, appears in these columns. An aerial is required, so is a ground; but both are incorporated in the cabinet in the form of a copper sheet in the cabinet top for an aerial, and a similar sheet in the bottom of the cabinet as ground. (Each plate is approximately 18 by 40 inches). This arrangement sacrifices distance to dispense with an outside aerial.

The electrical values for American tubes would be as follows: V1, '01A; V2 and V3, '40s; V4, '01A; V5 and V6, '40s; V7, '71A. R1, R2, 14-meg.; R3, 1/2-meg.; R4 and R5, 1/4-meg.; R6, 1 meg.; R7 2 meg.; R8, R9 1/2 to 1 meg.; R10, 1, 10-meg.; C1, .001-mf.; C2, .00025-mf.; C3, C4, C5, .01-mf.; C6, .0005-mf.; L1, 250-turn honeycomb coil; L2, 50-turn honeycomb coil; L3, 75-turn honeycomb coil. Note the grid and plate connections of tubes V1 and V2.

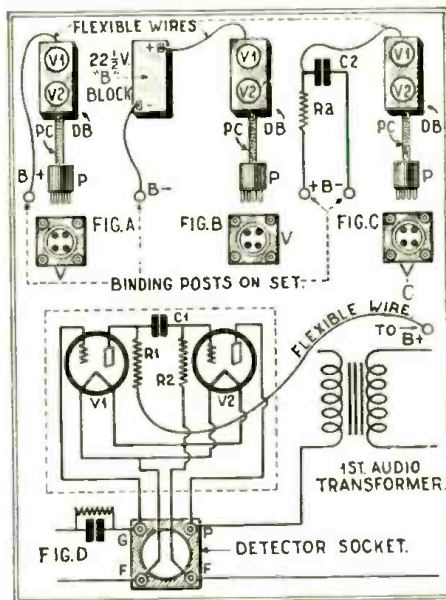

(Q. 37) The layout of parts and the alternative hook-ups of the "Detector Booster" are indicated in the above picture layouts (A, B, C) and schematic diagram (D).

**DEAD-END LOSSES—DETECTOR BOOSTER**

(37) Mr. J. N. Kiernan, Sioux City, Iowa.

(Q.) Please give your opinion of this "scheme" to simplify short-wave reception; instead of changing coils, a switch is used to select any portion of the grid and plate inductances.

(A.) The circuit referred to is reproduced in these columns. The purpose of changing coils in a receiver is to eliminate "lead end" effects. When using only the 20-meter section in the method suggested, there is considerable wire unused but remaining in the field of the active portion, to which it is also conductively coupled. This causes a great increase in the "high-frequency resistance;" the result is loss of signal strength.

The values of L1, L2, C1, and C4 must be determined by experiment and may be any convenient size. C2 is .00025-mf.; C3, .00015-mf.; C5, .000125-mf.; R1, 10 meg.; R2, 30 ohms; V, an '01A.

(Q.) Is the schematic circuit of the Detector Booster recently described in RADIO-CRAFT, obtainable now?

(A.) This circuit has recently been released and appears in these columns. The usual values for resistance-capacity-coupled audio amplifiers of this nature are: R1, 100,000 ohms; R2, 1 meg.; C1, .006-mf. Fig. A illustrates the usual connection to a radio set; in Fig. B a better arrangement is shown, which eliminates the instability that appears in certain critical circuits. Fig. C shows an alternative arrangement.

The schematic circuit is Fig. D. An extra resistor R3 of 50,000 ohms, and a condenser C2 of 1 mf. capacity, are shown in Fig. C, for preventing "motorboating" (the resistor R3 is known also as a "de-coupling" resistor). P is the booster plug; it plugs into the detector socket of a radio set, the tube being placed in socket V1 and an additional '01A tube inserted in socket V2. PC is the 4-wire cable shown in the schematic circuit.

**POLARIZED CHOKE—POWER DETECTOR—COIL DESIGN—SIDEBANDS**

(38) Mr. Herbert H. Jewell, Cumberland, Md.

(Q.) What size and kind of wire and number of turns should be used in winding an 85-milli-henry choke coil of small dimensions, for use in radio-frequency circuits?

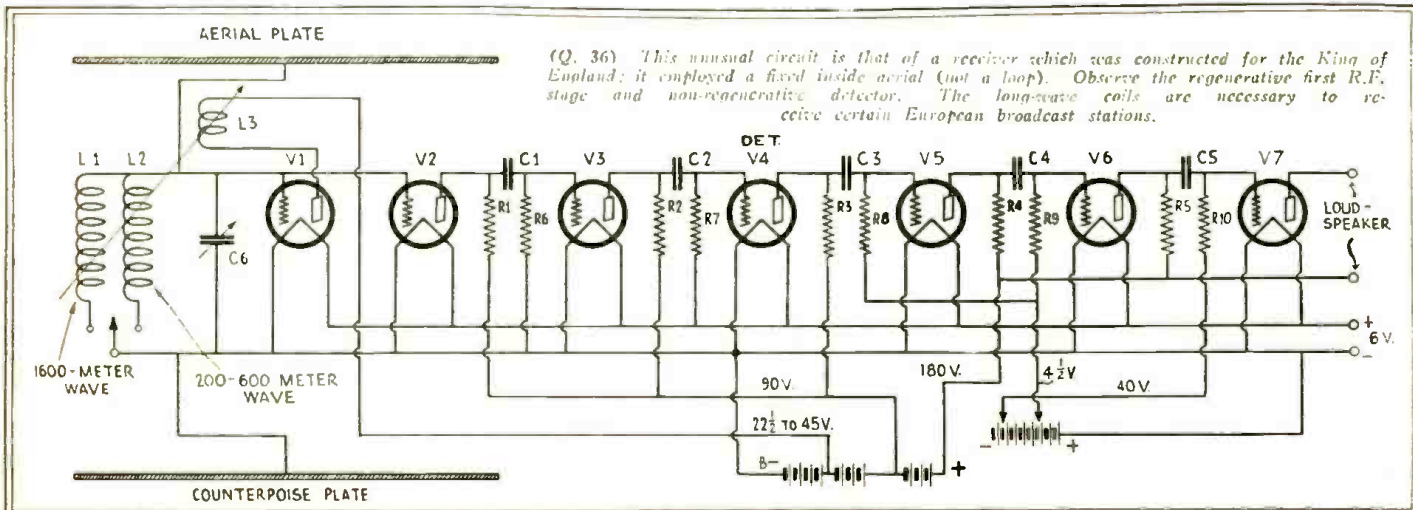

(Q. 36) This unusual circuit is that of a receiver which was constructed for the King of England; it employed a fixed inside aerial (not a loop). Observe the regenerative first R.F. stage and non-regenerative detector. The long-wave coils are necessary to receive certain European broadcast stations.



# LET RCA INSTITUTES START YOU ON THE ROAD TO . . . SUCCESS IN RADIO

Radio needs you . . . That's why the entire Radio industry is calling for trained men . . . That's why thousands of men who answered these advertisements are now earning from \$2,000 and up a year. Radio is thrilling work . . . easy hours, too, vacations with pay and a chance to see the world. Manufacturers and broadcasting stations are now eagerly seeking trained RCA men . . . Aviation and radio in the movies also provide innumerable opportunities . . . Millions of sets need servicing . . . thousands of ships require experienced operators . . . Never before was there an opportunity like this.



Radio Mechanic and Inspector \$1800 to \$4000 a Year.

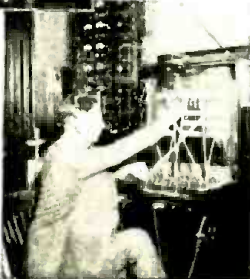

Broadcast Station Mechanic \$1800 to \$3600 a Year.



Land Station Operator \$1800 to \$4000 a Year.



Broadcast Operators \$1800 to \$4800 a Year.

### Graduates of RCA Institutes Find It Easier to Get Good Jobs

They are closest to the source of Radio's greatest achievements because the progress of Radio is measured by the accomplishments of the great engineers in the huge research laboratories of the Radio Corporation of America.

Students of RCA Institutes get first-hand knowledge, get it quickly and get it complete. Success in Radio depends upon training and that's the training you get with RCA Institutes. That's why every graduate who desired a position has been able to get one . . . That's why graduates are always in big demand.

### Study Radio at the Oldest and Largest Commercial Training Organization in the World

Send for our Free Book . . . or step in at one of our resident schools and see how thousands of men are already on the road to success in Radio. Remember that you, too, can be successful . . . can speed up your earning capacity . . . can earn more money in Radio than you ever earned before. The man who trains today will hold down the big-money Radio job of the future. Come in and get our free book or send for it by mail. Everything you want to know about Radio. 40 fascinating pages, packed with pictures and descriptions of the brilliant opportunities in this gigantic, world-wide money-making profession.

See for yourself why graduates of RCA Institutes now occupy thousands of well-paid positions. These positions are usually available in from 3 to 10 days after graduation for men who can qualify. RCA Institutes will back you up to the limit. Our catalogue is yours free . . . SEND FOR IT TODAY!

### This is the Only Course Sponsored by Radio Corporation of America

RCA sets the standards for the entire Radio industry . . . The RCA Institutes' Home Laboratory Training Course enables you to quickly learn all the secrets of Radio . . . In your spare time, in only an hour or so a day, you can obtain a thorough, practical education in Radio . . . You get the inside information, too, because you study right at the source of all the latest, up-to-the-minute developments. RCA, the world's largest Radio organization sponsors every single detail in this course.

You learn Radio by actual experience with the remarkable outlay of apparatus given to every student. You learn the "How" as well as the "Why" of every Radio problem, such as repairing, installing and servicing fine sets. That's why every graduate of RCA Institutes has the experience, the ability and the confidence to hold a big-money Radio job.

For the added convenience of students who prefer a Resident Study Course, RCA Institutes, Inc., has established Resident Schools in the following cities:

- New York . . . . . 326 Broadway
- Boston, Mass. . . . . 899 Boylston St.
- Philadelphia, Pa. . . . . 1211 Chestnut St.
- Baltimore, Md. . . . . 1215 North Charles St.
- Newark, N. J. . . . . 560 Broad St.

Graduates of both the Home Laboratory Training Course and the Resident Schools receive exactly the same training and enjoy the same privileges so far as jobs and salaries are concerned. And every Home Study graduate may also attend any one of our resident schools for post-graduate instruction at no extra charge.

## Clip this Coupon NOW!

**RCA INSTITUTES, INC.**

Formerly Radio Institute of America

SPONSORED BY



RCA INSTITUTES, Inc.  
Dept. RC-1, 326 Broadway, N. Y.

Gentlemen: Please send me your FREE 40-page book which illustrates the brilliant opportunities in Radio and describes your laboratory-method of instruction at home!

Name .....

Address .....

(A.) An R.F. choke of this rating may be made by winding three "pies" of number 34 S.C.C. wire on a form 1/4-in. in diameter; each section should be 3/16-in. wide. (A wooden rod with three grooves turned in it will be a convenient method of obtaining this form). In one end section, wind 750 turns; next, 700; and last, 800. The end of the 800-turn section should be connected to the plate (or high-potential) side of the circuit for best results; as this construction results in a "polarized" unit having greater choking action in one direction than in the other.

(Q.) What is meant by "linear power detection?"

(A.) The older methods of detector connection resulted in distortion on high power, due to the fact that the signal input exceeded the grid-bias potential. By raising the grid bias to a value not exceeded by the signal, operation on the "straight (linear) portion" of the tube's "characteristic" curve resulted; this point is covered by Mr. Palmer in his articles, "Vacuum Tubes for Radio Reception."

(Q.) Where is it possible to obtain specifications for winding short-wave coils, using various sizes of wire, for condenser capacities?

(A.) It is impossible to obtain such systematized information: for the simple reason that there would be no end to the data. It would consume the space of many large volumes: for the reason that tubes, aerials, condensers, coil placement, associated apparatus, shielding, winding forms, methods of winding and other factors vary critically at high frequencies. The only reliable method is that of winding a set of coils to suit the conditions in a receiver, following a general idea of the values; and varying the coils until exactly the desired tuning band is obtained.

This general idea of values may be obtained from published data: including the detailed specifications which have appeared in past issues of RADIO-CRAFT magazine, for coils covering the entire short-wave range.

(Q.) What is meant by "sideband elimination?"

(A.) The most complete and easily-understood explanations regarding this phase of radio of which we know appear in the article, "Building a 1930 Electric Receiver," in the November issue of RADIO-CRAFT, and in the "Cooperative Laboratory" last month.

**NEUTRALIZING—HUM BALANCER—CRACKLING**

(39) Mr. Chas. F. Lanouette, St. Albans, Vt.

(Q.) With the proper tubes in all sockets, what causes a Neurodyne to hiss on high wavelengths? I have an Apex set which is out of balance and oscillates on the low wavelengths. By adjusting the neutralizing condenser I stop oscillation on the low waves, but start a pronounced hiss at high wavelengths.

(A.) The hiss mentioned is due to too much circuit regeneration. The only remedy is to neutralize at the high wavelengths as well as the low. Detailed information on neutralizing a radio set appears in the Radio Service Data Sheet No. 8. (See page No. 251, December, 1929, issue of RADIO-CRAFT magazine.)

If the radio-frequency coils have changed their positions, this would explain the lack of balance on the higher wavelengths. Also, any change in the wiring might account for this. A loud-speaker cord brought too close to the tuning inductances of a set will often cause the effects described.

It may be necessary to install an "over-all" neutralizing capacity, to overcome the tendency to long-wave instability. Such a condenser arrangement is shown in the Radio Service Data Sheet No. 5, in the November, 1929 issue of RADIO-

CRAFT Magazine (page 208). Condensers NC3 and C20 are the two referred to.

(Q.) In balancing a neurodyne circuit by use of a tube with a shortened filament prong, as described in the November issue of RADIO-CRAFT (page 239), what is wrong when no reception results when this tube is used? The tube is OK, for the set works when the tube is pushed all the way in; but, as soon as the filament circuit is broken by partial removal of the tube, the set goes dead and no amount of "trimming" will bring reception through. This applies to all stages in the set. In fact, I have tried several times to apply this idea in both D.C. and A.C. neurodynes, but have never yet succeeded in getting reception from any set as soon as the filament circuit is opened via the shortened prong.

(A.) We are inclined to believe that total lack of reception, when using the shortened tube partly removed from the tube socket, is due to insufficient signal strength. If the circuit is partly neutralized, and this tube is partly removed from the socket, the signal strength is insufficient to actuate the following stage through the capacity coupling afforded by the tube. To apply this method, it is necessary to tune in a very loud station. For this reason, it is common practice to use a special audio-modulated R.F. oscillator for this purpose. Such an oscillator usually has only three wavelength adjustments: one, at the lower end of the tuning scale; one at about the middle; and a third adjust-

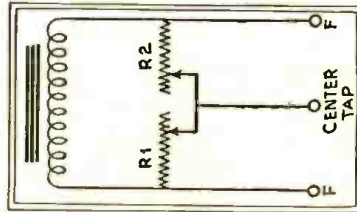

(Q. 39) As this illustration shows, two ordinary rheostats, R1 and R2, may be used as an emergency substitute for a hum-balancing potentiometer. This should be attempted only by experienced technicians.

ment near the upper limit of the tuning scale. (An oscillator of the continuously-adjustable type was described on page 152 of the October, 1929 issue of RADIO-CRAFT Magazine.)

(Q.) On electric sets not equipped with a hum adjuster, where can I attach a 20- or 30-ohm rheostat to balance out the hum? How could I use two of them on the same set?

(A.) For balancing out the hum due to an off-center filament connection, a potentiometer and not a rheostat is required. The position of a hum balancer is clearly shown in many schematic circuits which have appeared in past issues of RADIO-CRAFT Magazine; additional information on the center-tap problem appears in "The Cooperative Radio Laboratory" for the month of December.

Merely as an experimental alternative, the use of two rheostats in place of a single potentiometer is illustrated in these columns. R1 and R2 may be 10-, 20- or 30-ohm rheostats. It will be necessary to use care and judgment in handling these resistors, else they will "blow" when the resistance value between the arm and the connected end of the rheostat becomes too low.

(Q.) The battery cable on an Atwater Kent "30" produces a loud crackling sound when the cable is moved in a certain position, near the input to the set. I have tested this cable for open or short circuit, but find it OK in every respect; in fact it

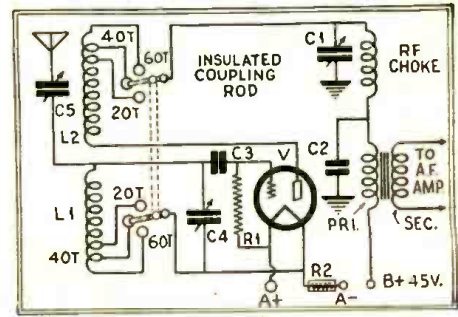

(Q. 37) The circuit shown above is suggested by several readers, as a good one for changing wavebands; however, it has disadvantages.

is a new one. Is there any form of inductive coupling, through some defective part in the set or accessories, which would cause this effect on the cable? Sometimes merely touching the cable with the finger causes the noise.

(A.) This crackling sound on the A.K. "30," or any other receiver having a cable connection, is caused by loose connections (perhaps corroded contacts), partial breaks, or partial shorts.

The reason the cable tested perfect is that the tests were not carried sufficiently far; or else the trouble does not rest in the cable.

It is possible that the trouble is due to poor connection at binding posts; perhaps a wire underneath a post is making intermittent contact. Corroded "A" battery clips will cause the same effect. A voltmeter placed across the filament connections of a tube will quickly indicate whether the "A" supply is fluctuating. If this reading is steady, check the "B" supply with a voltmeter or milliammeter.

A broken strand of cable conductor will occasionally cause this effect, when the strand sticks through the insulation and intermittently touches another lead.

There is no inductive action in the A.K. "30" circuit to cause this trouble.

**FEDERAL ORTHO-SONIC RECEIVER**

(40) Mr. L. K. Brandon, Shreveport, La.

(Q.) If available, please print the schematic circuit of the Federal "Ortho-Sonic" receiver, indicating values of the parts used. What type of circuit is used in this set?

(A.) The schematic circuit of this receiver has been reproduced in this department. All available information as to constants appears below.

Condenser C1, 100 mmf.; C3, .0005 mf.; C2, 42 mmf.; C6, 1.0 mf.; C4, 200 mmf.; C5, .001 mf.; The grid-plate capacity of about 9 mmf. has been represented in dotted lines; C7, .05 mf.; R1, 1 meg.; L1, 165 mh.

**PROTECTING AN INVENTION**

(41) Mr. Harry Stoops, Chattanooga, Tenn.

(Q.) There is a particular idea which I would like to protect, with a view to patenting it at the earliest convenience. Please suggest a procedure.

(A.) An expedient often resorted to, as a temporary record of the inception of an invention, is to write a complete description of the invention and of the experiments which have been made in reducing it to practice, and have it signed by a notary. Then, seal the paper in an envelope addressed to yourself, which is then sent through the registered mail. The envelope should be left sealed and, in case of a priority claim, certain proof is available.

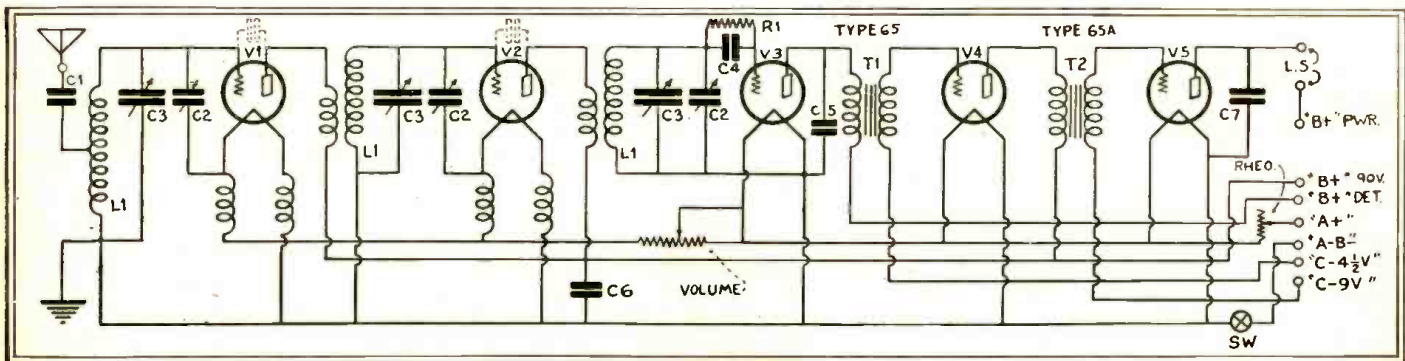

(Q. 40) Schematic circuit of the Federal "Ortho-Sonic" receiver. All available constants are given in the text.

# GREAT NEWS IN RADIO!



## A.C. SHORT-WAVE RADIO PILOT SUPER-WASP

With this short-wave outfit you pick up programs 10,000 miles away! You listen to the biggest thrills in radio—entertainment broadcast from foreign countries—new, different, exciting airventures! Available in easy-to-assemble kit form, in A.C. or battery types. Designed by 3 famous short-wave engineers—David Grimes, John Geloso and Robt. S. Kruse.



Kit K-115 (A.C. Operated)

**\$34<sup>50</sup>**

POWER PACK EXTRA  
(Pilot K-111 recommended)

Kit K-110 **\$29<sup>50</sup>**  
(Battery operated)



### Pilot Power Packs

K-111 for 171-A Tubes

Thorough filtration makes hum inaudible. Very compact. Output 220 volts. Recommended for A.C. Super-Wasp. Complete. \$16<sup>50</sup>  
by assembled and wired

K-112 for 245 Tubes

Easily handles two 245's in push-pull plus five or six 227 and 224 types. Output 300 volts. Ultra-compact. Completely assembled and wired \$19<sup>50</sup>

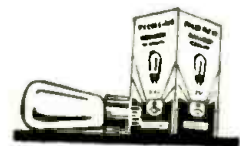

### PILOTRONS

Endorsed by  
Professionals

When radio engineers, professional set-builders, and advanced experimenters demanded a tube of vastly superior qualities, Pilot responded with Pilotrons. Their enthusiastic reception by radio's fustiest folks proves that here at last is a line of tubes made to professional standards. For example, Pilotron 227 was especially developed by Pilot engineers for both regular broadcast sets and for the A.C. Super-Wasp Short Wave receiver—and is the only A.C. Tube suitable for short-wave detection.

### DO YOU BELONG?

The Radio International Guild invites you to join its international organization of radio enthusiasts. Return the coupon now with 50c and receive membership pin, certificate and current issue "Radio Design." You will also receive 3 additional quarterly issues of "Radio Design"—the Guild's Official Organ.

RADIO INTERNATIONAL GUILD, 103 Broadway, Brooklyn, N. Y.

Enclosed please find 50c for which kindly enroll me as a regular member Radio International Guild which includes four quarterly issues of Radio Design membership pin, certificate and identification card.

Name \_\_\_\_\_  
(Please write or print plainly)

Address \_\_\_\_\_

City \_\_\_\_\_ State \_\_\_\_\_

# PILOT RADIO & TUBE CORP.

WORLD'S LARGEST RADIO PARTS PLANT—ESTABLISHED 1908

323 BERRY STREET

Prices quoted  
are for Custom Set-Builders  
in U. S. A.



TRADE MARK

BROOKLYN, N.Y., U.S.A.

Get Latest Catalog from nearest  
Authorized Dealer or Direct  
from Factory.

### Portable Test Set

(Continued from page 306)

indicates full scale reading, namely, 3 volts. The voltage is applied through the switch 6 set at the 3 volt position. Then remove the shorting wire across the condenser terminals and read capacity on the 115-volt scale. Compare meter reading with condenser table, Fig. 8—capacity value will be evident.

#### 110 A.C. for Continuity Test

I have made an adapter as shown in Fig. 7 that is compact and handy for circuit tests. It is equipped with binding posts so that special connecting wire is unnecessary; the regular adapter cable wire being suitable for use. Two wires are used on supply lines from socket to adapter, and the other two wires are the ohm-meter testing prods. A lamp bulb can always be borrowed from the set owner visited, hence it is unnecessary to carry a lamp. Any size (voltage capacity) can be used in this tester.

Another valuable aid to the service man is the socket arrangement booklet published by the E. T. Cunningham Co. giving the socket arrangement of several hundred different makes and models of radio sets. These sheets may be used for reference purposes after the respective grid, plate and filament voltages have been marked thereon. Also the watts consumed by the receiver in order to provide a basis for the solution of the correct voltage reducing resistances. Further, comment if the receiver is tested with the volume control "full" or "mini-

Supersedes Page N 7 of 8/29/28

Manufacturer,	ZENITH RADIO CORP.	1928
Model No.	31 P, 35 AP	
	342, 37 A	
	342 P	
	35 P	
Type,	A.C.	Uses .95 Watts

Socket Number	Volts	Circuit	Type	Recommended	Plate	Grid	K
1. 2.	1st	R.F. 100	C-327	6.	3.	6.	
2. 2.	2nd	R.F. 100	C-327	6.	3.	6.	
3. 2.	3rd	R.F. 100	C-327	6.	3.	6.	
4. 2.	Det.	A2	C-327	0.	3.	5.2	
5. 2.	1st	A.F. 100	C-327	6.	3.	4.	
6. 7.2	2nd	A.F. 400	CX-310	32.	20.	22.	
7.	2.25	(Rectifiers)			45.	(Rectifiers)	

Remarks: Dynamic speaker supplied with these models.  
2 CX-381's used in separate power units.  
line voltage 115

Fig. 15

A leaf of the Cunningham tube-layout booklet (reduced in size) as filled in by the author.

num," as this adjustment makes a great deal of difference with respect to current and voltage values. (See Figs. 15 and 16.) (To be continued in February RADIO-CRAFT.)

### Reginald A. Fessenden

(Continued from page 309)

Replacing his radio-communication work by other activities, Dr. Fessenden has since devoted a considerable portion of his time and genius to the subjects of navigation and signalling at sea. How well he succeeded in this field may be shown by the fact that, less than a month ago, the medal for promotion of safety of life at sea, awarded to him by the American Museum of Safety, was bestowed upon Dr. Fessenden for more than a dozen nautical safety devices: including the fathometer, which permits taking soundings without the use of a line, by reflection of sound waves; direction finders; and many other electrical and sonic inventions. The medal was received at an official gathering in New York by his son, Major Reginald A. Fessenden, Jr., in the absence of the doctor, who is now in Bermuda, the scene of his earliest post-college activities.

It may be of interest to know that, in addition to many works on mathematics and other forms of pure science, as well as its applications, Dr. Fessenden has made contributions to archeology and to ancient history. The interests of his restless and inquiring mind, in fact, have been almost universal; but no other branch of human activity, after all, is so deeply indebted to him for practical contributions as the science and art of radio telephony.

EVERY  
SERVICE MAN  
SHOULD OWN  
THIS BOOK!

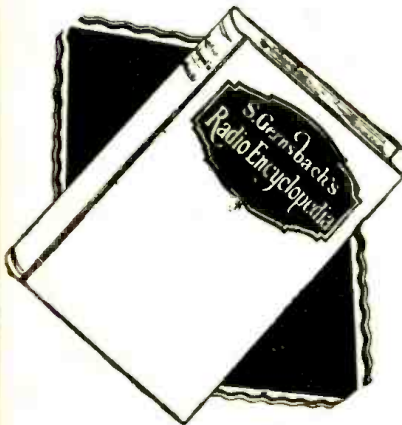

(1930 DEFINITIONS)  
**FULLY ILLUSTRATED**  
Size 9 x 12 in.  
Over One Inch Thick  
168 Pages  
Written in Plain English

## S. GERNSBACK'S RADIO ENCYCLOPEDIA

The First Real Radio Encyclopedia Ever Published

Regular Price \$2.00      Our Special Price \$1.49

EDITED by SIDNEY GERNSBACK, Author of "Wireless Course in Twenty Lessons" — "One Thousand and One Formulas" — "Practical Electricity Course" — "The Radio Educator," etc.

S. GERNSBACK'S RADIO ENCYCLOPEDIA is the only standard work ever published in America attempting to classify alphabetically the countless words used in the highly specialized science of RADIO. The ENCYCLOPEDIA is written in plain English so that everybody can understand the definitions and descriptions.

No expense has been spared, covering over two years in compilation, to make it worthy a place in your library.

It is published in one volume—168 pages—size 9 x 12 inches, over an inch thick and nicely accommodates the beautiful illustrations and the large, easy-to-read type.

The work contains 1,930 definitions, 549 photographs, drawings and diagrams.

REMEMBER THIS IS A REAL ENCYCLOPEDIA — NOT A DICTIONARY — and very few of the things described and illustrated in this volume can be found in any diction-

ary, or any other encyclopedia.

The book contains as a supplement a classified cross index designed to bring together radio references under one heading having relations in common.

All circuits new and old are described by word and picture and every part and apparatus used in Radio is explained and made understandable by means of photographs and drawings.

The volume is printed upon fine paper—bound in full black Keratol, marbled paper fly leaves and end sheets, with the title stamped in gold.

**SEND NO MONEY**

Just Pay Postman

(Canada or Foreign send Check or Money Order for \$1.75)

ISKOR PRESS, Inc., R-130  
286 Fifth Avenue,  
New York, N. Y.

Send me one copy of Sidney Gernsback's First Radio Encyclopedia in one volume as advertised. I will pay postman \$1.49 plus postage on delivery.

Name .....

Address .....

Town and State.....

# WHOLESALE PRICES

## For Dealers, Service Men, General Repairmen and Set Builders!

**F  
R  
E  
E  
C  
A  
T  
A  
L  
O  
G**



Our new, HUGE LARGER PAGE SIZE (8" x 10 1/2") WHOLESALE CATALOG No. 19, 2nd Edition, enjoys the enviable distinction of being universally accepted by the RADIO TRADE in the same manner that a school treasures the Dictionary and Encyclopedia Britannica—or the home, the Bible and Almanac!! Those "in the know" regard our catalog AS THE OFFICIAL ORGAN OF THE 1929 RADIO SEASON!!!

This FREE CATALOG is literally a most valuable ENCYCLOPEDIA—YOU cannot well afford to be without one—and you do not have to. Your request for one is all that is needed!

In these many years we have been in the Radio Mail Order Business, we have learned to GAIN AND RETAIN THE GOOD WILL OF OUR CUSTOMERS. In this, our DETERMINED GOAL, RADIO SPECIALTY COMPANY OFFERS TO SHIP PRACTICALLY ALL ORDERS IN FROM 6 to 24 HOURS — OFFERS YOU 100% MERCHANDISE ON A STRICT MONEY-BACK BASIS IF NOT SATISFIED — AND OFFERS YOU ALL MERCHANDISE AT ABSOLUTE ROCK-BOTTOM NET PRICES!

Our Catalog Lists More  
**Completely Assembled  
All-Electric A. C. Receivers**  
than any other Radio Catalog!

Available in chassis form, or mounted on table or console cabinets, with and without built-in loud speakers.

**OUR ROCK-BOTTOM NET PRICES FOR THESE SETS WILL ASTOUND YOU!**

In this new catalog there are also listed large assortments of CAMERAS, HOUSEHOLD ELECTRICAL APPLIANCES AND ELECTRICAL TOOLS OF EVERY DESCRIPTION.

### HERE ARE TWO OF OUR BIG BARGAINS

Order From This Page—Send Money Order—Check—or Postage Stamps

#### RASCOS REPLACEMENT AUDIO TRANSFORMERS

Can be mounted in either of three positions, that is, lying down, or standing up with the core parallel to the base on which it is resting, or standing up with core perpendicular to the base. Other replacement transformers can only be mounted two ways. There are six specially designed feet to provide the most convenient choice of mounting, and any of them can be removed at will, should you so desire. Thus, it is logical to conclude that our Replacement Transformers can be installed in ANY receiver, either custom or factory built, no matter how small a space there may be available, whether such mounting is to be above, or beneath, a subpanel, or baseboard. The coils themselves are of the first quality, and are only found on the most costly transformers. The core is the highest grade silicon steel, and of ample proportions. A happy combination of electrical values in both the core, and coil, assure

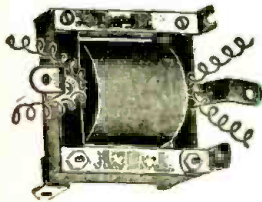

maximum amplification possibilities—more than sufficient volume, yet with no trace of distortion! The silicon steel stampings are very rigidly bolted together by a generous size bar which is attractively nickel plated. 2 1/4 in. long by 1 1/4 in. high by 2 1/4 in. wide.  
No. 7900. Your Net Cost..... **\$0.80**

#### TERMINAL STRIP MODEL

The primary and secondary leads are spaghetti covered, and unusually well soldered to generous size lugs. Strip is bakelite and properly lettered.  
No. 7950. Your Net Cost..... **\$1.01**

#### DUO-MAGNETIC CONE SPEAKER CHASSIS

No other magnetic speaker chassis is so strongly constructed! Note the heavily ribbed, sturdy "spider leg" white-lead casting! The entire frame work is one piece—a beautifully molded job! A Duo-Magnetic cone speaker unit is bolted to the rear mounting plate of the chassis, and the Burtex "ribbed" cloth cone is fastened between two heavy rings of cardboard—these rings are held in place by either screws and nuts, bolted to the frame of the chassis, or by being pressed up against a baffle mounting board. Although this speaker can be used as illustrated, it is strongly recommended that it be used in conjunction either with a baffle board or mounted within a box, a cabinet, or speaker compartment space in any console. The tone quality is comparable to any speaker selling for many times its retail cost. Will stand all the volume any radio set can "give it." Will work satisfactorily with a D.C. or an A.C. set—with 90 volts applied through it, or even as high as 500 volts! No blasting! No distortion! No rattling! You will be most impressed with its splendid performance! Overall dimensions: Diameter 9 in., width of mounting ring 1/2 in., depth rear of unit to mounting baffle board plate 6 1/4 in.; diameter of unit mounting plate 4 1/2 in.

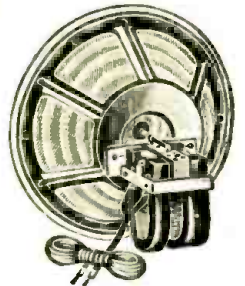

No. 6850. COMPLETELY ASSEMBLED, Including DUO-MAGNETIC UNIT and cord. (As illustrated.) Your Special Net Cost..... **\$6.75**  
No. 6852. MOUNTED IN A CABINET OF EXTRAVAGANT BEAUTY. Your Net Cost..... **\$9.44**

# RADIO SPECIALTY CO.

BUY FROM RADIO'S OLDEST MAIL ORDER HOUSE

**98C Park Place  
New York City**

# The NEW H-F-L Mastertone Laboratory Made Receiver

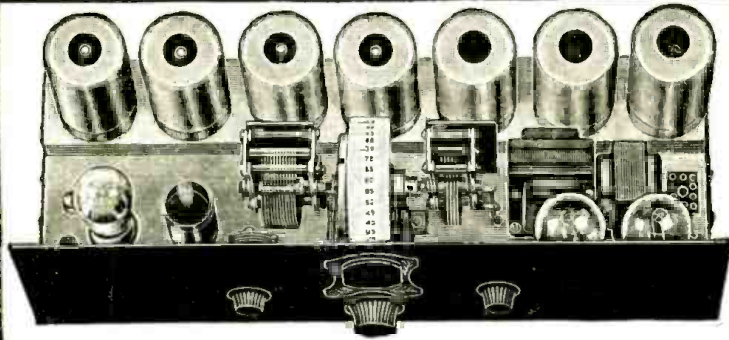

**Completely Built and Assembled by  
H-F-L Engineers—Shipped ready to Operate**

All metal completely shielded chassis: 7" x 21" x 7½". Fits nearly all consoles. 11 tubes operating at peak efficiency [5-224; 3-227; 2-245; 1-280.] Single dial positive one-spot tuning; Humless AC Operation; Uses 5 Screen-Grid tubes, 5 Tuned R. F. Circuits; High Power Screen-Grid detector, with 175 volts impressed on plate; Automatic line voltage control inbuilt holds voltage against fluctuating; 100-Volt DC Dynamic field supply incorporated; 3 stage Phonographic amplifier; Finest quality precision made parts.

#### Amazing Power

Startling realism! Unfailing accuracy! Its great power and sweet tone awe and thrill, setting new standards of performance achieved by H. F. L. engineers after two years of tireless research and tests under all conditions.

#### Keenest Sensitivity

Unlike any ever known! Gets distant stations clearly, sharply, distinctly with only wire screen or metal plate aerial built in cabinet.

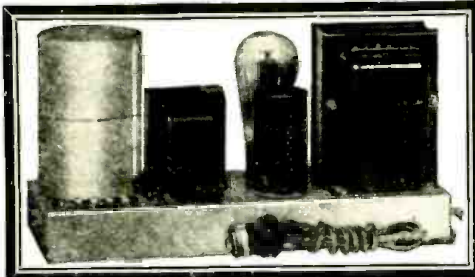

#### Highly Developed Circuit

Intermediate employs 4 screen-grid tubes with 5 tuned filter circuits, easily adjustable to peak of tuned frequency. Positive 10 Kilocycle selectivity. Most highly engineered receiver ever built.

#### The New Audio System

Uniform amplification over entire musical scale. Operates with dynamic, magnetic or horn speakers without a bit of hum.

#### The H-F-L Power Master

Not an ordinary power pack, but a specially developed unit of the Mastertone, built separately to simplify installation. Has oversized transformer, full wave type 280 rectifier tube.

#### Built by Hand—Yet Low in Price—

Quality—not quantity—the H-F-L Mastertone standard. One demonstration will convince you that its the master receiver of all times. Fully guaranteed.

Write today for complete description and price.

**HIGH FREQUENCY LABORATORIES**  
28 North Sheldon St. Dept. 72 Chicago, Ill.

THE OUTSTANDING LITERARY SUCCESS  
IN THE MAGAZINE WORLD

*The Twin Magazines of Science Fiction*

Science  
**WONDER**  
Stories

25c  
The  
Copy

**AIR**  
WONDER • STORIES

SPECIAL OFFER — 8 MONTHS OF EITHER \$1.00  
STELLAR PUB. CORP. 98R Park Place, New York City

## Service Men's Notebooks

(Continued from page 297)

and touch the test leads to the terminals of the arrestor. There should be no click; if one is heard, there is a ground or other fault and the arrestor should be replaced with a new one.

High-resistance joints in an aerial or ground lead encourage broad tuning and, in some cases, excessive regeneration. They may be found by using the voltmeter and battery in series, and applying the test prongs across the various joints. (Fig. 2) If the joint is perfect, the reading of the voltmeter should be the full value of the battery; if there is a perceptible difference, the drop is through the resistance of the joint.

Lack of volume in battery sets is often the result of low "B" battery voltage; in a good many cases, broad tuning can be traced to this cause. Batteries should be discarded when the voltage falls off more than one sixth (below 37½ volts for a 45-volt battery). They may operate longer; but as a rule, they become noisy and the fault mentioned above develops. In fact, much of our so-called "summer static" is the result of "B" battery trouble. Noise and lack of volume develop also if the plates of an "A" battery are allowed to become *sulphated*, or the battery-terminal connections to be corroded. The connector clips and battery terminals should be cleaned with a strong solution of soda and water, or even plain water, and then heavily coated with *vaseline* (make sure first that the clips have a good grip on a *clean* metallic surface). The battery should never be allowed to become completely discharged and left in that condition; better yet, never let the charge fall below a specific gravity of 1.200.

Lack of volume is caused also by condenser plates being out of alignment; any deviation of the rotor plates from the exact middle of the spaces between the stator plates will affect the tuning, and likewise the volume. If only a few plates are out of line, or improperly spaced, this may be corrected with a screw-driver. If the entire rotor is out of line, loosen the screws holding the entire assembly; move it just the proper distance to center the plates, and retighten. Great care must be used in this operation, that the plates do not turn either way; or the condenser will be thrown out of step.

#### Testing Ground Connections

Another cause of broad tuning and lack of volume is an ineffective "ground," resulting from bad soil conditions. Many installations do not have the ground rods driven deep enough. During the summer months, when there is drought, the ground dries out below the rod. Even though the soil does not become dry enough to act as an insulator, the resistance is greatly increased by lack of moisture. The same results of shallow grounding may be experienced during extremely cold winter weather, when the ground freezes below the ground rod. We then have broad tuning, loss of signal strength, and of course, decreased reception range.

If trouble in the ground system is suspected, this may be investigated by driving a test ground rod into the soil, making sure

that it is in moist soil, and applying the voltage test as shown (Fig. 3). If the voltage reading is very low, a high resistance through the ground is indicated. All connections on the ground rods should be soldered in this case.

The writer wishes to impress on installers and service men the importance of a good ground equal to that of a good aerial; if this were not true, the manufacturers would leave off the "Gnd." connections of their sets. *Radio reception is no better than your aerial and ground systems.*

Another cause of much annoyance, which is not always suspected, is the swaying of trees over the aerial; this produces many mysterious noises and periodic fading, due to the short to ground through the trees. Even if the aerial does not touch the tree, the effect is produced due to the capacity which exists.

### Service Men's Forum

(Continued from page 297)

*as more than his rebuke discourages us. We think that all readers appreciate that the method described by Mr. Freed on quick repairs is adapted best to old sets, for which the owner does not care to meet the cost of new parts, and which will soon be superseded; as well as for temporary repairs, the importance of which Mr. Alcorn has pointed out. There is no doubt that a new part is better than a mended one: and in a new set the cost is justified. There are also, as Mr. Kipling observes, cheap repairs for the cheap ones. If the customer prefers to pay for a good job, he should have it, by all means. We shall be glad to have from Mr. Matthews as many of the 1,001 bits of practical experiences as he cares to send in. As for Mr. Teslu, that distinguished scientist has been for some years in retirement.—Editor.)*

### Operating Notes

(Continued from page 303)

In the Crosley "Showbox" and "Show-Chest" (A.C. and D.C. models) if we find, after the set has been in operation for some time, that touching the tuning control results in crackling and generally noisy operation, it is caused by a bad contact between ground and the rotor of the gang condenser. Connect a wire from rotor to chassis to remedy this condition.

When a shorted "B" output is found in a Crosley A.C. receiver, look at the leads from the choke where they pass through holes in the chassis. The leads have sleeves made of live rubber; if it cracks and exposes the leads, vibration of the set may cause a short to the chassis.

#### Phonograph Adapters

With the vogue of power detection, it is well to bear in mind that it will be found difficult to use a phonograph pick-up with a set of considerable output. The output of the pick-up requires additional A.F. amplification, before it is led to the input of the power tube.

A high-pitched whistle in the Kolster "K20" and "K21," where the pack and audio amplifier is in the rear of the R.F. chassis, may be remedied by placing a grounded

# "N.Y. ELECTRICAL SCHOOL" Men

## Graduate into many fields...



AVIATION  
ELECTRICITY

AUTOMOBILE  
ELECTRICITY



NAUTICAL  
ELECTRICITY

ELECTRICAL  
ENGINEERING



A full knowledge of electricity, as taught in the New York Electrical School, makes you independent, gives you your choice of either a BIG PAY job with one of the world-famous electrical companies, or a business of your own. ELECTRICITY is also a stepping-stone to Aviation, Automobile Engineering and other highly paid professions.

Here at the New York Electrical School you learn, not by correspondence, but by ACTUAL PRACTICE on full-size standard equipment. NO BOOKS used. Individual instruction—you can start any day. This School owns and occupies two seven-story buildings in New York—the city of most opportunities. It is widely known as the country's oldest and foremost institution for trade training. That's why big companies eagerly demand our graduates.

### THE NEW YORK ELECTRICAL SCHOOL

21 West 17th Street, New York



**FREE**

This big 64-page booklet gives full information about the New York Electrical School courses and picture of the equipment available for your personal use. Send for it TODAY. It's free.

MAIL TODAY

The New York Electrical School  
21 West 17th Street, New York

Please send me FREE your 64-page booklet. It is understood that this request puts me under no obligation.

Name .....

Address .....

**Choice of 1200  
Newest  
RADIO  
VALUES**

SEND for our wholesale 1930 catalog. Filled with amazing values in screen grid radios, 245 push pull audio, radio consoles, kits, parts. Guaranteed merchandise at wholesale prices.

**FREE**

**WESTERN RADIO MFG. CO.**  
124 W. LAKE ST. CHICAGO ILL.

**Cuts Radio Tube Costs**

tubes \$2.50  
tubes \$1.95  
tubes \$3.50

AMPERITE automatically keeps voltages exactly right for tube efficiency. Lengthens tube life. For all tubes, \$1.10 with mounting (in U.S.A.) As all dealers.

**AMPERITE Corporation**  
661 BROADWAY, NEW YORK  
FREE—"Amperite Tube Chart." Write Dept. RC-1

**AMPERITE**  
REG. U.S. PAT. OFF.

The "SELF-ADJUSTING" Rheostat

# SKINDERVIKEN Transmitter Units 95c



Two for \$1.75

Have hundreds of uses. Every amateur should have two or three of these amplifiers in his laboratory.

### A FEW USES FOR THESE UNITS

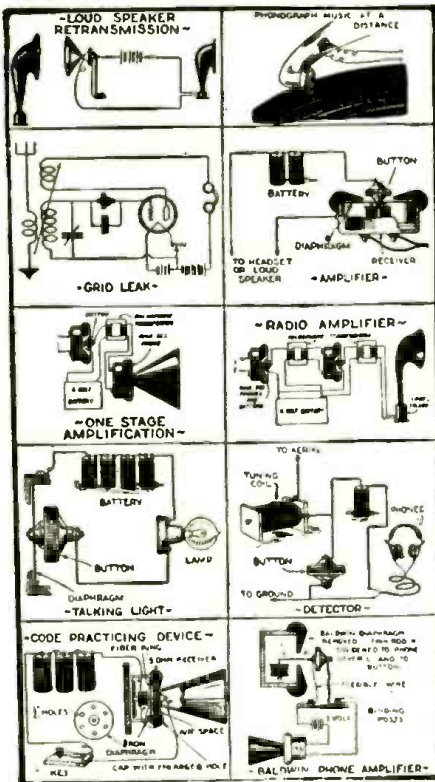

12-PAGE INSTRUCTION BOOKLET containing suggestions and diagrams for innumerable uses, furnished with each unit.

**WE PAY \$5.00 IN CASH** for every new use developed for this unit and accepted and published by us.

### P. G. Microphone Transformer



A Modulated Transformer specially designed for use with the Skinderviken Transmitter Unit. Has many other uses. Primary resistance, 1/2 ohm; secondary, 55 ohms.

2

**FOR SALE AT LEADING DEALERS**  
Or Order Direct, Using Coupon Below  
**SEND NO MONEY**

When the postman delivers your order you pay him for whatever you have ordered, plus a few cents postage.

PRESS GUILD, Inc., 16-18-R East 30th Street, New York, N. Y. R-1-30  
Please mail me at once as many of the following items as I have indicated.  
... Skinderviken Transmitter Units at 95c. for 1; \$1.75 for 2; \$2.50 for 3; \$3.20 for 4.  
... P. G. Microphone Transformers at \$2.  
When delivered I will pay the postman the cost of the items specified plus postage.

Name .....  
Address .....  
City ..... State .....

## The Evening World

THURSDAY, NOVEMBER 14, 1929.

### RADIO OPENS NEW, PROMISING FIELD FOR TRAINED MEN

#### Shortage of Operators Seen Coming by Department of Commerce Head

Rapid growth of radio communication is enlarging a comparatively new field of employment for young men with many opportunities, says the Radio Division of the Department of Commerce.

There is a shortage of trained radio operators which threatens to become acute within the next few years. J. H. Barron, in charge of commercial operators for the department, says. Of 7,000 licensed commercial operators in the United States, practically all are employed and the demand is increasing steadily.

The projected establishment of radio message systems in the United States competing with wire lines and development of television and other forms of visual broadcasting will open up new fields for operators and technicians. Use of additional frequencies such as those above the 23,000 kilocycle band will provide new opportunities for experienced radio men.

The radio division itself, as well as other governmental departments, has had considerable difficulty in obtaining qualified men as inspectors. There are sixty-three inspectorships in the country and half a dozen vacancies exist.

#### FAMILY AFFAIR

Just one more evidence of the increasing demand for thoroughly trained service men, nowadays.

metal cap over the power tube (not the detector tube).

The easiest method of replacing the condenser cord drive on the Majestic "71" and "72" is to remove the condenser gang and dial from the chassis. This is done as follows: first, remove the shield can over the gang; then unsolder all leads to the condensers, and also the pilot light. Finally, loosen the three screws holding the gang "bathtub" to the chassis, and lift both gang and dial from the chassis. After the cord has been replaced, the procedure outlined above is reversed.

Choked signals in the Radiola "8AC" are due to a defective condenser (in the pack) across the '10 bias resistor. Check this condenser.

The Radiola "18AC" uses only two 1-mf. condensers in the pack for filtering purposes, with heavy chokes and choke input.

Noisy Fada models "10" and "16" have been repaired by replacing the first audio transformer.

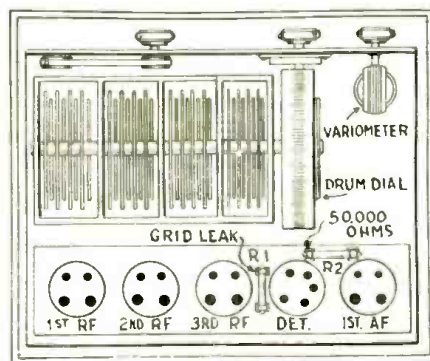
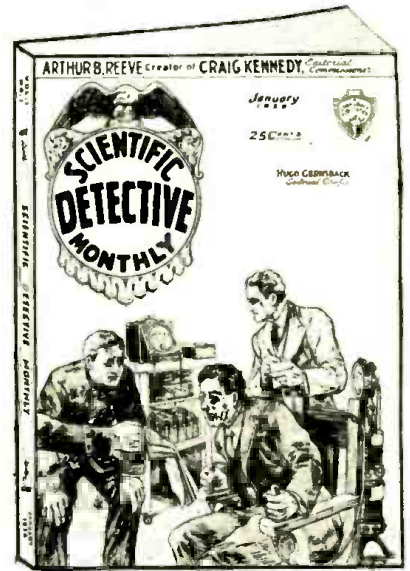

Fig. 4

Bosch "28" and "29" chassis.

and NOW we present



On All Newsstands

100 Pages 4-Color Cover

25c The Copy

**SCIENTIFIC DETECTIVE MONTHLY**, the first national detective monthly with a scientific background, will have as its Editorial Commissioner, Mr. Arthur B. Reeve, the foremost science fiction writer and author of the world-read "CRAIG-KENNEDY" SERIES.

In the first issue of SCIENTIFIC DETECTIVE MONTHLY you will read "The Bishop Murder Case" by S. S. Van Dine.

A brand new Craig Kennedy story, and many other scientific detective stories written by such famous authors as Dr. David H. Keller, Captain S. P. Meek, U. S. A., etc.

Begin with the initial issue of SCIENTIFIC DETECTIVE MONTHLY and read the world's finest scientific detective stories. Subscribe now and have each issue mailed to you regularly every month. To all charter subscribers we offer a special price of

**8 MONTHS \$1.00 FOR**

(Canada and foreign \$1.25)

TECHNI-CRAFT PUB. CORP., 98RC Park Place, New York, N. Y.

Enclosed find \$1.00 for which please send me SCIENTIFIC DETECTIVE STORIES for eight months. (Canada and foreign \$1.25.)

Name .....  
Address .....  
City ..... State .....



## Cause of Interference

(Continued from page 308)

controls to the interfering signal a second time, and readjust the trap's condenser until the undesired signal entirely disappears or is reduced to minimum intensity. The wavetrapped control is then left in this position as long as this particular frequency is to be eliminated. The receiver is operated in the usual way, to select the desired signals.

### Theory of the Wavetrapped

The wavetrapped functions as a resonant circuit to permit alternating current to flow at a certain frequency. By varying the capacity of the variable condenser the capacitive reactance (condenser opposition) is made equal to the inductive reactance (coil opposition); thus cancelling out these two forms of opposition which oppose current flow at a particular frequency. The circuit is then reduced to one possessing only ohmic resistance (that of the wire itself) thereby allowing the maximum current flow. The purpose of the "absorption" wavetrapped in Fig. 1 is to absorb the particular undesired frequency to which it is tuned, so that little or none of it will reach the receiver.

A view and schematic diagram of a "rejector" type wavetrapped is shown in Fig. 2. It is composed of a three-inch tube, on which are closely wound 50 to 55 turns of No. 22 D.C. wire, and a .0005-mf. variable condenser connected in parallel with the coil. The operation of this wavetrapped is identical with that of the type just described, and it has practically the same effect upon the tuning of the receiver.

The circuit consists of an inductance (coil) and capacity (condenser) connected in parallel; this combination, in turn, is connected in series with the antenna. By means of the variable condenser it is possible to adjust the trap circuit to resonance with the frequency of the interfering signal. When this condition is obtained the trap circuit offers the least impedance to the interfering signal frequency and "by-passes" it from the main antenna circuit, thereby allowing it to flow back and forth between the condenser and coil. In this manner the undesirable frequency is prevented from entering the receiving circuit. This arrangement is most successful when the antenna is exceptionally long, or the receiver is connected to a poor ground. This wavetrapped, therefore, can be advantageously used in conjunction with the more or less non-selective types of receivers which are located near broadcast stations.

### Oscillating Receivers

Regeneration is the process of feeding back energy from the plate to the grid of a vacuum-tube circuit. This is permissible and, in fact, an asset to a receiver. When carried beyond a certain point, however, regeneration (in the proper sense of the word) ceases; and the receiving circuit becomes an oscillating circuit. As such it is a generator of high-frequency oscillations; in this condition it is in reality a transmitter. (See Fig. 2A.)

The power of the radiated energy from an oscillating receiver is weak when compared to that of a broadcast transmitter; yet it radiates sufficient energy, occasionally, to destroy a broadcast program being received by a neighboring set, if the two sets are tuned

to the same program. Manufacturers of modern receivers employing a regenerative detector always design the circuit so that oscillations of this nature are prevented from reaching the antenna; but some of the earlier types of receivers were not designed to take care of such a condition.

If a shrill whistle is heard, at time breaking into the program with a violent chirp, and at other times gradually rising and falling in pitch when the controls of the receiver are not being manipulated, it is a fair indication that someone in the immediate neighborhood is operating a receiver in an oscillating condition. As the trouble is due to improper operation of the set, the only remedy is to locate the owner of the offending set and inform him of the interference he is creating.

(In forthcoming issues of RADIO-CRAFT Mr. Bristow will continue his articles with a study of natural and "man-made static," and a description of the methods used most successfully to locate and remedy the latter.—Editor.)

## "A. C. Super-Wasp"

(Continued from page 311)

the receiver, the actual "B" voltages delivered by the power pack are higher than the standard figures indicated. These figures are correct when the power pack is loaded with a six- or seven-tube set; but the higher values on light load are just right for the "Super-Wasp." For instance, the 90-volt tap actually delivers about 175, and the 45-volt tap about 65; this is a good combination for the screen-grid tube. The 135-volt post gives about 170, which is not too much for the detector because a 500,000-ohm plate resistor is used. The 180-volt post gives about 190, which is all right because part of this is taken up by the grid-biasing resistors for the audio tubes.

As far as results are concerned, the Super-Wasp is a real performer. Although preliminary tuning must be done with phones, the set gives loud-speaker signals in New York from stations G5SW, Chelmsford, England; PCJ, Eindhoven, Holland; CJRX, Winnipeg, Canada; W6XX, Oakland, California; NRH, Costa Rica, Central America; and, of course, the Pittsburgh and Schenectady groups. Such "DX" loud-speaker reception is not, of course, 100% reliable; but it is frequent enough to make the set a "loud speaker" outfit. The receiver stays sold; and that is the most important thing from the standpoint of the commercial constructor.

No detailed instructions as to assembly or point-to-point wiring are given here; for they are supplied with the kit, along with a full-size working blueprint.

## Six-Inch Radio Waves

(Continued from page 312)

parallel to the electric field, about a wavelength away. The rod was itself at the same time excited to its natural oscillations at the same frequency, and thus became a secondary radiator. In this way the intensity of reception could be noticeably increased. A similar experiment could be demonstrated at the receiving side.

To produce a directed radiation there was

## Read what engineers have to say about Rider's "Trouble Shooter's Manual"

RADIO CORPORATION OF PENNSYLVANIA  
331 Fourth Avenue  
Pittsburgh, Pa.

August 23, 1929.

Radio Treatise Co.,  
1440 Broadway, New York City.  
Gentlemen:

We have received John F. Rider's "Trouble Shooter's Manual" which our instructors, who are Westinghouse Electric and Manufacturing Company and Radio Corporation of America engineers, recommend highly and say that all of our radiotrician students should have a copy.

Very truly yours,  
Radio Corporation of Pennsylvania,  
(Signed) W. R. Jones,  
Business Manager.

Is a higher recommendation possible? You too, if you are interested in radio and radio service will find Rider's

### "TROUBLE SHOOTER'S MANUAL"

of infinite value. Wiring diagrams of more than 200 models of radio receivers . . . Trouble Shooting information . . . How to find the trouble . . . The possible troubles and symptoms in radio frequency amplifiers—detectors—audio frequency amplifiers—A eliminators—B eliminators—a wealth of vital money-making information . . . THE BOOK WILL BE WORTH HUNDREDS OF DOLLARS TO YOU . . . 22 chapters of vital information—the kind of dope you need in your service business . . .

### Wiring Diagrams of These Commercial Receivers

Radio Corp. of Amer.	Federal
Atwater-Kent	Crosley
Zenith	Majestic
Fada	Stromberg-Carlson
Stewart-Warner	Grebe
Philco	Freshman
Freed-Eisemann	Kolster
All-American	Day-Fan
Colonial	Workrite
Amrad	Spartan
DeForest	Ware
Garod	Kennedy
Operadio	Sleeper
Magnavox	Grimes

240 PAGES 8 1/2" x 11", BLACK STURDITE BINDING

RADIO TREATISE CO.  
1440 Broadway, New York City  
Send No Money

RADIO TREATISE CO.,  
1440 Broadway, New York City.

Send me John F. Rider's "Trouble Shooter's Manual" and I will pay postman \$3.50 plus a few cents for postage on delivery. It is understood that my money will be refunded if I am not entirely satisfied.

Name .....

Address .....

City..... State.....

## CLASSIFIED ADVERTISEMENTS

Advertisements in this section are inserted at the cost of ten cents per word for each insertion—name and address each count as one word. Cash should accompany all classified advertisements unless placed by a recognized advertising agency. No less than ten words are accepted. Advertising for the February 1930 issue, should be received not later than December 10th.

### AGENTS WANTED

**FREE BOOK.** Start little mail order business. Hadwil, 27A-74 Cortlandt Street, New York.

**GET OUR FREE SAMPLE CASE** — Toilet Articles, Flavorings, Soaps, Specialties. Wonderfully profitable. LaDerma Co., Dept. SC, St. Louis, Mo.

### AIRPLANE SUPPLIES

**MODEL AEROPLANE** Supplies. Write for free bundle of sample stock. Aero Shop, 3050 Huribut Ave., Detroit, Mich.

### BUSINESS OPPORTUNITY

**CAPITAL.**—An experienced dependable broker will aid in financing projects of merit. Amster Leonard, East Orange, N. J.

**SELL BY MAIL.** Books, Novelties, Bargains! Large profits. Particular FREE! D. Elfeo, 521 South Dearborn, Chicago.

### CHEMICALS

**BOOKLET OF EXPERIMENTS** and chemical catalog. 15c. General Chemical Company, Box 397, Reading, Penna.

### DETECTIVES

**DETECTIVES** Earn Big Money. Excellent opportunity. Experience unnecessary. Particulars Free. Write, George Wagner, 2190B Broadway, N. Y.

### INSTRUCTION

**I CATCH** from 45 to 50 foxes from 4 to 5 weeks' time. Can teach any reader of this magazine how to get them. Write for particulars. W. A. Hadley, Stanstead, Que.

**LEARN MARBLEIZING** Concrete products all kind. Wood, Metals, etc. Resembles polished marble or onyx. Wonderful for garden furniture, table tops, etc. Write, Cowell Institute, Grayling, Mich.

**BE THE LICENSED RADIO DOCTOR** of your community. Earn \$7.00-\$10.00 spare time evenings. Write now for free booklet. "Why the Radio Doctor?" Dept. C, 131 Essex Street, Salem, Massachusetts.

**LEARN TATTOOING.** Instruction catalog, dime. Miller, N431 Main, Norfolk, Virginia.

### MONEY

**FOR SALE** — UNITED STATES commemorative silver half dollars. Pilgrim, 90 cents. Monroe, Lexington, 1921 Pilgrim, Bennington, \$1 each. Oregon, Lincoln, Grant, \$.25 each. G. T. Davis, Box 1791, Huntington, West Virginia.

### NUMEROLOGY

**FOR 1930 NUMEROLOGICAL** forecast send 20c. and birthdate to Martha Sanchez, 824 Howard, Detroit, Michigan.

### OLD MONEY WANTED

**\$5 to \$500 EACH** paid for Old Coins. Keep ALL old money. Many VERY valuable. Get Posted. Send 10c. for illustrated Coin Value Book, 4x6. Guaranteed Prices. We buy and sell. COIN EXCHANGE, Room 10. Le Roy, N. Y.

### PATENT ATTORNEY

**PATENTS** — Time counts in applying for patents. Don't risk delay in protecting your ideas. Send sketch of model for instructions or write for free book, "How to Obtain a Patent" and "Record of Invention" form. No charge for information on how to proceed. Communications strictly confidential. Prompt, careful, efficient service. Clarence A. O'Brien, Registered Patent Attorney, 343-A Security Bank Building (directly across street from Patent Office), Washington, D. C.

### RADIO STAMPS

**15 RADIO STATION STAMPS**, no two alike \$1. Chas. A. Philidius, 510 E. 120th St., New York, N. Y.

### REAL ESTATE

**OZARKS.** 40 Acres Missouri. \$5 month. Own a home. Jarrell, Mt. Vernon, Ill.

### SONG POEM WRITERS

**POETRY AND SONG** writing taught in 12 lessons. For particulars enclose 10c. R. D. Higginbotham, 263 Bartlett St., San Francisco, Calif.

placed behind the tube a parabolic mirror about 50 centimeters (19.7 inches) across, the tube being located at the focus of the mirror. In this way it was possible to produce an almost parallel "pencil" of rays. If a metal screen was placed in this, in such a way that the pencil fell diagonally on the screen, the rays were reflected in accordance with the laws of optical reflection. Their course could be followed exactly at the same time with the detector. (See Fig. 3.)

The phenomena of diffraction, which are well-known in optics, could also be demonstrated with this radiation of waves. A round metal disc, 50 centimeters in diameter, was placed in the path of the rays. If the receiver was placed close behind this screen, no reception could be obtained; that

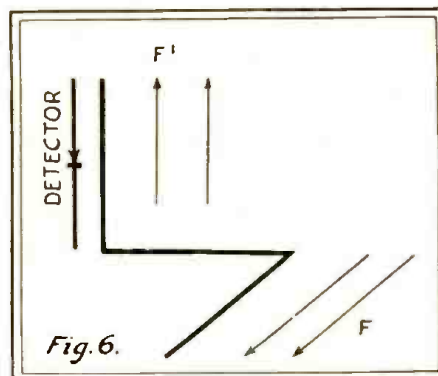

Fig. 6. The heavy line indicates the short coupling rod, which would pick up a signal in one of its sections; and, by the flow of current, transfer the signal to the detector.

is, the receiver was completely in the "electrical shadow" of the screen. At a distance of about a meter (39.37 inches) from the metal screen, however, the wave could be received again; that is to say, the waves curved around the edge of the screen. By moving the receiver still further away, it was possible to find in turn "maxima" and "minima"! This phenomenon corresponds to the well-known Arago experiment in optics; which shows the bending of visible light around the edge of a circular disc.

The refraction of the wave-radiation was demonstrated by letting the parallel pencil of rays from the transmitter fall on a glass lens about 30 centimeters (a foot) in diameter. By using the detector behind the lens, it was possible to demonstrate clearly the course of the radiation and in particular the place of greatest intensity, the focus of the lens.

### Absorption of Waves by a Conductor

With this arrangement, the absorption of the waves by various substances was very beautifully shown. If a sheet of cardboard, hard rubber, dry wood, or a glass vessel of paraffin oil, was placed between the lens and the detector, there was no weakening of the reception. But, if a glass vessel of distilled water was placed in the path of the rays, the radiation was almost completely absorbed.

Fig. 1 shows this experiment: the rays emitted by the tube are made parallel by the parabolic mirror. The parallel rays strike the glass lens and are concentrated by this into a focus; the detector is set up at this point. The glass vessel, between the lens and the detector, contains the liquid which is to be tested as to its absorption.

# HOTEL CENTURY

111 West 46th Street

Just East of Broadway

JUST COMPLETED

N. Y. City

350 ROOMS — 350 BATHS

*This New Hotel contains every modern appointment*

*Every Room has Private Bath*

**\$3 Per Day**

Situated in the heart of the city; near Railway Terminals. All Leading Shops and Theatres within a stone's throw.

J. H. PRICE, Resident Manager

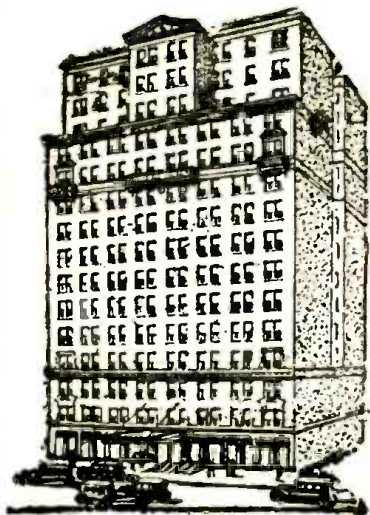

# OUT December 15<sup>th</sup>

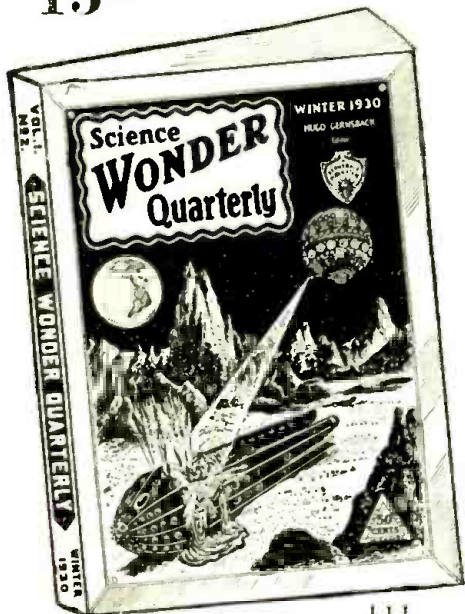

144 PAGES  
4-COLOR COVER

## THE MOON CONQUERORS By R. H. Romans

Mr. Romans is a modern Jules Verne and his story of two planets will undoubtedly rank with the "Shot Into Infinity" as one of the best interplanetary stories of recent years.

AMONG THE OTHER STORIES ARE:

## INTO THE 28<sup>TH</sup> CENTURY By Lilith Lorraine

## THE OSMOTIC THEOREM

By Capt. S. P. Meeks,  
U. S. A.

The subscription price of the QUARTERLY is \$1.75 per year, single copy 50c.

To charter subscribers, a special price of \$1.25 per year is now available. This offer will positively be withdrawn after January 1, 1930.

**50c** The  
Copy  
On All Newsstands



STELLAR PUBLISHING CORP.,  
Dept. RC-1, 98 Park Place, New York, N. Y.

Enclosed please find \$1.25 for which send me the next 4 issues of SCIENCE WONDER QUARTERLY. (Canada and foreign \$1.50.)

Name .....

Address .....

City..... State.....

One of the most interesting experiments is the production of vertical electric waves. For this purpose the parallel rays are reflected perpendicularly from the concave mirror upon a metal screen, as shown in Fig. 2. The parallel rays strike perpendicularly on the circular metal disk and are thereby reflected. The approaching wave and the reflected wave coincide, between the concave mirror and the metal disc, and cause a vertical wave. If the detector is at one of the places marked with white in the illustration, the maximum strength of reception is secured. Between these places one gets tone minima. These maxima and minima correspond to the crests and nodes of the vertical wave.

### Polarization Effects

The distinctive polarization of the waves was shown by means of the Hertz polarization grid. (See Fig. 4 and 4a.) This grid consists of a row of parallel copper wires, stretched 1 centimeter (0.4-inch) apart on a wooden frame 40 centimeters (16 inches) square. When this grid was placed in the path of radiation between the transmitter and the detector, with the grid wires perpendicular to the electric field, there was no influence on the reception. But when the frame was revolved 90 degrees, so that the wires lay parallel to the electric field, the radiation was almost entirely shut off.

A further interesting experiment was the rotation of the plane of polarization. For this there was used a wire shape made up of three copper rods at right angles to each other, each 7 centimeters long (that is, half the wavelength). If the axis of the receiver rod was placed perpendicular to the electric field *f* there was no longer any reception. But, if the wire shape was placed before the receiving rod in such a way that one of the end-wires was parallel to the rod, reception could be clearly heard. In this case, in fact, the first length of wire lay parallel to the movement of the electric field and thus, by coupling, conveyed the primary oscillations into a direction perpendicular to the primary field; so that there resulted a secondary electric field *f*<sub>1</sub> in this direction. (See Fig. 6.) This may be regarded as a model experiment for the rotation of the plane of polarization by the flow of electrons.

### A Tube Receives Its Own Waves

By two experiments, for the conclusion, there was shown the possibility of tube-reception. For this purpose, the radiation sent from the tube was reflected back upon the tube. In one case the metal screen above described was used to do this; in the second case a small linear resonator, 7 centimeters long, was sufficient. It was shown that, according to the position of the resonator (*i.e.*, the phase of the reflected radiation) the plate current of the tube can be modified. This experiment proves the possibility of reception of a wave by the very tube which sends it out and, at the same time, constitutes an actual, visible indicator of the operation of the tube.

Lately, Dr. Kohl and his co-workers have even succeeded in making directional telephone experiments over an experimental distance of about 1,500 meters. The tubes used for receiving and transmitting in these experiments were absolutely alike; so that

## For the Thrill of GREAT DISTANCE

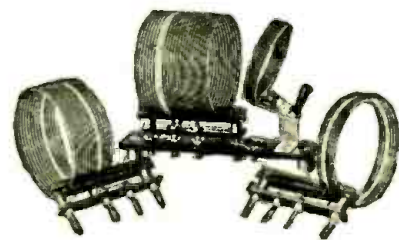

### Build a SHORT-WAVE RECEIVER

**H**AMMARLUND Short-Wave Plug-in Coils and Condensers, built into a short-wave receiver or adapter, will let you in on world-wide radio programs.

By plugging in coils of different sizes, wavebands from 15 to 215 meters can be fully covered.

Hammarlund Short-Wave Coils and Condensers share the fame for high quality that has kept the name Hammarlund in the forefront since the birth of radio.

Send 10c for instructive Short-Wave Manual. Address Dept. R.C-1

HAMMARLUND MFG. CO.  
424-438 West 33rd St. New York



## Choice of 1200 Newest RADIO VALUES

SEND for our wholesale 1930 catalog. Filled with amazing values in screen grid radios, 245 push pull audio, radio consoles, kits, parts. Guaranteed merchandise at wholesale prices. **FREE**

WESTERN RADIO MFG. CO.  
124 W. LAKE ST. CHICAGO ILL.

When it comes to making sick radios well,  
or good radios better just

Remember there's a **CLAROSTAT** for Every Purpose

For literature, write CLAROSTAT Mfg. Co.  
295 N. 6th St., Brooklyn, N. Y.

When writing to advertisers, please mention  
RADIO-CRAFT

**44<sup>TH</sup> ST.  
HOTEL**  
Just East of B'way

*One of New York's  
New Hotels at Right Prices*

A high-class hotel in the very center of Times Square and within walking distance of all Shops, Theatres, etc.

**300 Rooms—300 Baths**  
**\$2.50 & \$3.00 per Day**

A Restaurant of Unusual Excellence  
*Special Weekly Rates*

## 10 Tools in One

A SMALL but handy article which serves for every possible need of the all-round mechanic. Invaluable in any emergency.

An excellent combination of utilities for the household—every necessity featured: HAMMER — KNIFE-SHARPENER — NAIL-PULLER — BOTTLE-OPENER — SCREW-DRIVER — CORK-SCREW — CAN-OPENER — WEIGH-SCALE — RULER — TABLE OF WEIGHTS AND MEASURES

Just glance at the illustration and you will see how really useful this article is. The "Ten in One Tool" is 10 inches high and finely nickel-plated.

The new tool is not only handy in the household, but every TOURIST, AUTO-IST, CAMPER, PICKNICKER, BOY-SCOUT, FISHERMAN, CANOEIST, etc., should carry in his bag one of these indispensable combination tools. No SHOP, OFFICE, STORE, GARAGE, FARM, BOAT, should be without one. PRICE \$1.00, POSTAGE PAID.

Be the first one to own the "Ten Tools in One" in your own town.

Send your order today, pin a dollar bill to coupon below and the shipment will go forward to you the same day as received.

**GREN PARK TOOL CO.**  
245 Greenwich Street  
New York, N. Y.

Grenpark Tool Company, R.C.-130  
245 Greenwich Street,  
New York, N. Y.

Enclosed find \$1.00 for which please send me prepaid your "Ten Tools in One."

Name .....

Address .....

Town..... State.....

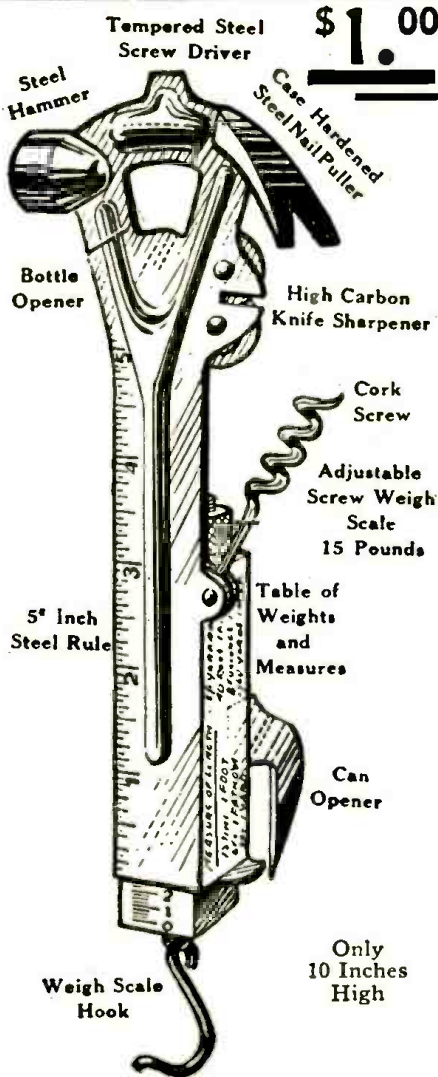

Mail Coupon  
Send for Yours  
**TO-DAY**

there was a possibility of using them alternately for the purposes of conversation.

There is a great field of possibilities for the use of these short waves. Thus, in the technique of communication, they will be serviceable wherever the communication is to take place within the range of vision, but, above all, in cases where definite directional radiation is desirable for signal purposes (e.g., for coastal shipping and aviation).

In medicine there seem to be great possibilities of their use in ultra-short-wave diathermy (i.e., the application of internal heat by short waves). Very recently an intensive investigation has been made of the physiological effect of short waves, about three meters in length, which has led already to surprising results at this frequency. Possibly shorter waves will prove still more effective. It should be recalled that an absorption maximum of water is found just at the frequency of the 14-centimeter wave.

Finally, let us call attention to the possibility of the spectroscopic investigation of matter with these four-inch spectral lines. Along this line we may expect probably many discoveries regarding the inner structure of matter.

## A Novel Scanning Disc

(Continued from page 314)

opening of the receiving set. The chances are 2:303 to 1, that the picture will not be framed, but askew, or with portions in inverted order; so that the outer portions of the sent image are apt to appear in the body of the received image. To overcome this irregularity, the disc must be braked by applying a momentary pressure on the motor spindle, or perhaps—for a slight misframe—by blowing the breath against the disc; the feeble mechanical energy so applied being ample to decelerate the speed momentarily without disturbing the normal speed which prevails by virtue of the rheostat's adjustment. After a little practice, the experimenter can successfully hold his picture rock-steady and practically "nailed to the screen."

Trying to tune in a picture or silhouette without a speed indicator is a hit-and-miss proposition, with the chances of success far outweighed by those of uncertainty; since the technician's sole clue is derived from observation of the blending shadows at the picture opening. A brief analysis reveals that even the slightest overspeed or underspeed, at the moment when synchronous speed is being passed over, will cause the picture to pass out of view without being recognized. The speed of the disc should be absolutely determinable. With a 48-hole disc, at 900 r.p.m., 15 complete pictures are coming over each second, and the neon-tube flashes are instantaneously produced; but each flash—occurring in 1/34,560th of a second—must be located by a scanning-disc hole and, if this hole is ahead or behind that of the corresponding hole of the distant scanning disc at the transmitter, the picture is going to be distorted.

Suppose that the receiver disc is going one per cent too fast; it will have a speed of 909 r.p.m., which means that successive pictures are progressively farther and farther misframed. A single picture which occurs in 1/15th of a second is recognizable; but, if

this has superimposed upon it, 1/15th-second later, another picture substantially identical with the first, but overlapping it by *one per cent*, it is apparent that the sharpness of outline is destroyed. If a continual succession of such progressively-overlapped pictures are being defined by the small opening of the television receiver, nothing but a cloudy surface of pinkish light appears; although each and every picture, individually, is perfect. Under conditions of *one per cent* off speed, the *accurately framed pictures appear only once for every 100 pictures registering on the disc*; so it is easy to see why synchronism is the key to television.

**Persistence of Vision Applies Also to Reading Speed**

The speed indicator is of the familiar centrifugal type. A spring is opposed to a sliding speed-pointer which, being a dull black, contrasts with the buffed background of the whirling disc; so that, as the disc speeds up, and the pointer moves farther and farther away from the axis of rotation—because of centrifugal force—a black circle of constantly-increasing size appears on the face of the disc. Through the persistence of vision, just as when a spark is twirled around at the end of a string, the circle appears stationary at any fixed speed. On the face of the disc is scribed a circle, which registers with the whirling-pointer circle when the speed is 900 revolutions.

**Television in Colors**  
(Continued from page 317)

same manner in which voice frequencies are controlled; that is, by manipulation of "gain" and "fader" circuits (Fig. E).

For color television, the three images must be received in their appropriate colors, and viewed simultaneously and in superposition. The first problem was to find light sources which, like the neon lamp previously used, would respond with the requisite fidelity to the high-frequency signals of television, and at the same time give red, green, and blue light. With such lamps available, a decision would have to be made as to how the three colors could best be combined to form a single image.

Several methods of reception are possible. For displaying the transmitted image to a large audience a big, zig-zag grid could be employed; but it would consist of three parallel tubes, instead of a single one used in earlier television demonstrations in one color.

Thus far the television images have been received in a manner similar essentially to the method for monochromatic television. The surface of a disc similar to that used at the sending end is viewed, and the light from the receiving lamp is focused on the pupil of the observer's eye by suitable lenses.

To combine the light of the three lamps, they are placed at some distance behind the scanning disc and two semi-transparent mirrors are set up, at right angles to each other, but at 45 deg. to the line of sight (as shown in the upper right of cabinet, Fig. H). One lamp can be viewed *directly* through both mirrors, and one lamp is seen *by reflection* from each, as illustrated by the schematic diagram (Fig. G).

**Obtaining Blue and Green**

The matter of suitable lamps to provide the red, green, and blue light has required a great deal of study. There is no difficulty about the red light; because the neon glow-lamp which has been used previously in television can be transformed into a suitable red light by interposing a red filter. For the sources of green and blue light, however, nothing approaching the efficiency of the neon lamp was available. The decision finally made was to use another one of the "noble gases"—argon—which has a very considerable number of emission lines in the blue and green region of the spectrum. Two argon lamps are employed; one with a *blue filter* to transmit the blue lines, and one with a *green filter* transparent to the green lines of its spectrum.

These argon lamps, unfortunately, are not nearly so bright as neon lamps and it was, therefore, necessary to use various expedients to increase their effective brilliancy. To work at high current intensities, special lamps were constructed with long narrow cathodes, made hollow so that streams of cold water could cool them. The *cathode is viewed end-on*; this greatly foreshortens the thin layer of glowing gas and thus increases its apparent brightness. Even so, it is necessary to operate these lamps from a special output amplifier to obtain currents as high as 200 milliamperes.

**The Receiver**

The receiving apparatus, at present, consists of one of the 16-inch television discs used in earlier experimental work. Behind it are the three special lamps and a lens system which focuses the light into a small aperture in front of the disc. The observer, looking into this aperture, receives (through each hole of the disc as it passes by) light from the three lamps—each controlled by its appropriate signal from the sending end. When the intensities of the three images are properly adjusted, he sees a combined image in its true colors, and with the general appearance of a small colored motion picture.

**Technical Difficulties**

Satisfactory television in colors is a far more difficult task than monochromatic television. Errors of quality which would pass unnoticed in an image of only one color may be fatal to true color reproduction, where three such images are superimposed and viewed simultaneously. In three-color television, any deviations from correct tone rendering destroy the balance of the colors; so that, while the three images might be adjusted to give certain colors properly, others would suffer from an excess or deficiency of certain of the constituents. A further source of erroneous color exists at the scanning end: *if the light from the object is not distributed equally to all the cells, the object will appear as though illuminated by lights of different colors shining on it from different directions.*

Color television constitutes a definite further step in the solution of the many problems presented in the electrical communication of images. It is, however, obviously more expensive, as well as more difficult, than the earlier monochromatic form; for it involves the use of extra communication channels as well as additional apparatus.

**This Free Book shows how you can get into AVIATION**



Walter Hinton

First to pilot a plane across the Atlantic, first to fly from North to South America, first to use the plane in exploration, first world-famous flyer to give home-study students the cream of his knowledge. Get Walter Hinton's own message to you, his Free Book, "Wings of Opportunity."

HERE'S the book that tells just where your chances are in Aviation today. It gives definite answers to the questions you've been asking yourself—"What does Aviation offer me?"—"What must I do to get into Aviation?"—"What job can I hold?" It explains how Lieutenant Walter Hinton, through a remarkable personalized home-study course can give you—**RIGHT AT HOME**—the ground-work employers demand. This intensive home-study course in Aviation is getting cash results for Hinton's graduates in all parts of the country. He also backs you up with an active employment service when you are ready for a job. If you want to take up flight instruction, he arranges for special reduced rates at an accredited flying school.

Send for this book today. The time you now spend thinking about Aviation could be spent in training.

**Mail Now for Facts**

Walter Hinton, President 304-C  
Aviation Institute of U. S. A.  
1115 Connecticut Ave., Washington, D. C.

Please send me your Free Book showing how I can train right at home for a place in Aviation.

Name..... Age.....  
(must be 18)

Address.....

City..... State.....

**LIFE-TIME DX AERIAL**

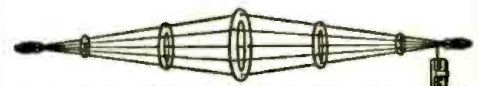

Guaranteed Double Volume and Sharper Tuning

**DESCRIPTION OF LIFETIME DX AERIAL**

No. 30—LENGTH 30 FEET: Assembled ready to string up. Brings in volume of 150-ft. wire but retains the selectivity of a 30-ft. aerial. Rings are heavy gauge solid zinc. Duplicates in design and non-corrosive materials the aeriels used by most of largest Broadcasting Stations. Design permits using this powerful aerial in 30-ft space (preferably outside). Sharpens tuning of any receiving set because of short length but has enormous pick-up because 150 ft. of No. 14 enamelled wire is used. Made for owners of fine radio sets who want great volume on distance without destroying sharp tuning. (Also used by many owners of short-wave outfits.) "Makes a good radio set better."

PRICE \$10.00

No. 60—LENGTH 60 FEET: Assembled ready to string up. "BIG BOY" Size (same description as above except that 300 ft. of wire is used, making this the most efficient and powerful aerial possible to manufacture).

PRICE \$12.50

Manufactured by  
**THOROLA RADIO PRODUCTS**  
1014 So. Michigan Blvd. Chicago, Illinois

**RADIO BARGAINS**

- Brand new 7-tube A. C. chassis, guaranteed...\$29.75
- Short Wave 1-tube sets..... 4.75
- Used 5-tube radios, table models. Require minor adjustment..... 6.90
- Power Transformers and Condenser Blocks at extremely low prices. Send for bargain list of sets, accessories and parts.

CHAS. HOODWIN CO.  
4240 Lincoln Ave. Dept. A-15, Chicago  
DEALERS IN BANKRUPT RADIO STOCKS

# Can You Outguess O. Henry?

Can you look ahead in an O. Henry story and see the unexpected denouement, the strange twists of plot, the breath-taking finish? Try it! If you succeed, you can out-think the best minds in the world, for the genius of O. Henry sets the wits of the brilliant people of all lands working at top speed—and still he amazed them all! He is the supreme master of the "trick" ending, luring you into sudden laughter while a lump still lingers in your throat—making you gasp by a sudden vivid flash of horror in the midst of a smoothly flowing tale.

## Stories of Wit and Pathos

Gentle is O. Henry, but manly strength glows in every virile sentence; tender with the suffering; ever kind to the under dog; chuckling with the light-hearted—drawing always from his unlimbed depths of understanding the sparkling crystal of comedy. A great writer, yet the most entertaining and thrilling companion. Reading his stories is like listening to a

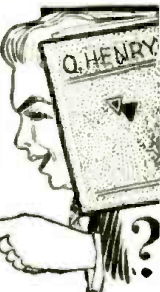

## The Master Story Teller

more brilliant story-teller than you ever knew. His works immeasurably enrich the limited library, and grace the shelves of the most crowded.

53 BEST STORIES

Less than **\$1.97**  
4 cents each

You are now offered for the first time 53 engrossing, living, selected stories, handily and durably bound in leatherette, stamped with gold. 500 pages, all for the price of only one ordinary short novel.

## Why DO YOU READ?

For entertainment? For escape from daily drabness? For romance, adventure, thrills? To sharpen your wits or exercise your emotions? Whatever your reason, O. Henry scores a bull's-eye on every point.

### CUT PRICE COUPON

GRENPARK COMPANY, Dept. R.C.-130,  
245 Greenwich St., New York, N. Y.

Please send me O. Henry's Best Stories at the cut price of \$1.97. I enclose stamps, check or M. O. for the amount. (Check which.)

Name .....

Address .....

City and State .....



## PATENTS TRADE-MARKS

**DON'T LOSE YOUR RIGHTS  
TO PATENT PROTECTION**

Before disclosing your invention to anyone send for blank form "EVIDENCE OF CONCEPTION" to be signed and witnessed.

**LANCASTER & ALLWINE**  
(Registered Patent Attorneys)  
475 Ouray Bldg., Washington, D. C.  
Originators of forms "Evidence of Conception"

## SONG WRITERS!

Substantial Advance Royalties are paid on work found acceptable for publication. Anyone wishing to write either the words or music for songs may submit work for free examination and advice. Past experience unnecessary. New demand created by "Talking Pictures". Fully described in our free book. Write for it Today—Newcomer Associates  
731 Earle Building, New York, N. Y.

## Screen-Grid Tubes

(Continued from page 321)

not exceed 75. The control grid is brought out at the top of the bulb, as in the '22 type.

### As a Radio-Frequency Amplifier

In order to obtain stable operation in circuits designed to give normal gain per stage, it is necessary to use shielding to separate the input and output circuits. The internal shielding of the tube makes neutralization unnecessary, provided extraneous external couplings are eliminated by means of shielding. Suitable ventilation, however, must be provided through the shielding to prevent excessive tube temperatures. Radio-frequency filters should be used in circuits employing more than two stages, and also in circuits which are designed to give the maximum amplification per stage. The high plate circuit impedance necessary for obtaining the normal amplification may be obtained either with closely-coupled R.F. transformers or by means of the tuned-plate-impedance method.

### As a Detector

The '24 is an excellent bias detector, with either small or high signal input. The screen-grid voltage and control-grid bias should be so chosen that the control grid does not swing to a point where grid current is drawn. For small R.F. signals, when a first audio stage is used, it is best to operate the screen grid at 35 or 45 volts, and the control grid at 3.5 or 4.5 volts, (negative) respectively.

Fig. 3 is a typical schematic diagram of a circuit in which the A.C. screen-grid tube is employed both as a radio-frequency amplifier and as a detector. One method of shielding the circuit is suggested by the dotted line; at the bottom are shown the connections to the base and socket of the tube.

## The 7-Grid Tube

(Continued from page 321)

thirty-two and sixty milliamperes, under the correct barometric pressures. The tube, however, being enclosed in the usual glass vessel, and the air exhausted, the barometric pressure, so far as the grid biases are concerned, may be left out of our calculations for the present. The reason is that the mutual conductance gives a rather undistorted output at normal plate current.

### Result

From this rather technical description, it may be gathered how simple it is to now calculate the final result, which gives us the total amplification factor; and which shows also the reason why the tube works better at sea level rather than at high altitudes. The calculation for the amplification factor is as follows:

Due to the fact that a negative filament voltage is used and that, consequently, the flow in amperes is minus two, this, multiplied by the thirty milliamperes on the other side is again multiplied into the normal plate voltage of 250. This product, multiplied by the electron emission of 2,658,999, gives a mutual conductance of approximately eighty-three billion. Again multiplying this by the "mu" factors of 7, we arrive at the

staggering total of a net amplification factor of forty-eight trillion, which gives us the REAL amplification factor of this tube.

From which it may be gathered that, if we use this tube, no other instruments of any kind are necessary and, by simply hooking the tube to an aerial and ground, and using nothing but a loud speaker, we should get the most wonderful music with ear-splitting intensities.

The fact, however, is that nothing of the sort happens, for the good and sufficient reason that (if you have survived thus far, you may have guessed it!) the beautiful seven-grid tube is nothing but an excellent April First joke constructed by Baron von Ardenne for the amusement of his friends.

## Tube Testing

(Continued from page 323)

for a number of characteristics. These included the filament current, the filament emission, plate current, "gas current," electrical leakage, amplification constant, plate resistance and mutual conduction. In some of the smaller factories, tubes are still tested by hand; but it is not possible to use this method in the largest plants, as too great a number of hand-test machines would be necessary, with a corresponding number of operators.

It must be realized that it was very difficult to maintain each of the test units so that each would keep the same degree of accuracy. In other words, if a battery setting were wrong, a meter off calibration, or a circuit did not always make perfect contact, some time might pass before the machine operator would discover the discrepancy; and this would cause the rejection of a number of good tubes or, what is worse, a number of poor tubes might be passed on. Also, the operators of the hand machines were not infallible and some poor tubes were always passed on.

### Machine Testing

Under the spur of a real need for test equipment functioning with super-human speed and accuracy, a machine has been made which automatically sorts the tubes into groups—those with broken filaments; those with low emission, or "gassy" ones, as well as those with high leakage between the elements; those with characteristics outside of the specified range of plate current; and fourth, the good tubes. By classification of the defects in this way, it is possible for the engineers to trace back the sources of trouble and make the necessary corrections. (This single fact alone means a great benefit to the tube user, in the form of a dependable product).

The machine consists of an electrical control-board, joined by means of a cable to the mechanical apparatus which connects the tubes in succession to the various test circuits. An automatic loading device with moving belts conveys the good and the defective tubes separately away from the machine.

The fundamental idea of the tester is that tubes are automatically placed in a socket and, by means of a rotating disc equipped with contact rings and brushes, they are successively connected into electrical circuits specially designed to test for the desired characteristics. The circuits are also

designed so that they operate an ejector which will throw out a tube which is defective in any test. A control relay with a sensitivity of .05-ma. (each control relay is nothing but a meter; a contact arm being substituted for the indicating vane) releases the ejector relays, so that tubes which pass each test satisfactorily are permitted to travel on to the next. The arrangement of the contacts is such that the test circuits allow the meters to come to a fixed position before the ejector circuit is connected.

The ejector consists of a solenoid which pushes the defective tube into the entrance of a chute; and a good tube must pass three of these chutes before it is finally delivered as O. K. by the machine. The diagram of the test unit is shown in \*Fig. 3, so that interested technicians can get an idea of the arrangement.

**Four Rejections**

The first circuit is designed to eject tubes with defective filaments; this classification includes open filaments, short-circuits between the filament and the plate, and short-circuits between the grid and plate. The circuit consists of two telephone relays, a protective resistor, and a power-control relay which operates the solenoid. The second circuit removes tubes classed as 'gassy, leaky' (with leaks between filament and plate or between grid and plate), or with low filament emission. The automatic tube tester also makes a double check on the first test, by the second circuit's also rejecting the tubes under that class. The third circuit rejects tubes with either low plate current or high plate current. The diagram will give some indication as to just how these tests are made—at a speed of 8,000 tubes per hour.

\* The information for this test unit is taken from a paper published by the "Radio Club of America," which may be obtained from Mr. L. G. Pacont, Chairman of the committee, 91 Seventh Avenue, New York City.

**From Microphone to Modulator**

(Continued from page 325)

the Spiltmore Ballroom through KNN—" A relay clicks minutely in the large speech-amplifier panel behind us, and a red light suddenly flashes in the right-hand corner of the switchboard.

"—the Paramount Pictures—Evening Express Station, Hollywood, California. The next number will be a violin solo entitled 'Caprice Viennois,' by Kreisler, played by Calmon Luboviski."

The red pilot goes out and at the same time another flashes just below. The studio at our left, which has been softly illuminated by indirect lights concealed near the ceiling, suddenly brightens, and through the plate glass window we see Luboviski lifting his bow to the strings of his violin. With a yawn the operator picks up the telephone, depresses the black talking key, and murmurs, "Well, so long, Bill."

He throws the red switch, and the pair of extension-circuit pilot lights go out. "Thus endeth the Spiltmore hour," he comments.

"Well," we inquire, puzzled by this performance, "what happened?"

"You have seen," replied the operator, "what is known to the trade as a 'split-

sentence change-over.' As the announcer was on duty in the next room, I let him manipulate the controls, although they are in duplicate so that I can announce from this desk if desired. The instant the announcer uptown pronounced the words 'KNN,' our announcer next door pushed a couple of buttons on his control cabinet and cut over from the extension line to his own mike, finishing the sentence.

"The upper red light shows that the announcer is on the air. The one just below is a microphone pilot, placed in series with the tube filaments of the audio amplifiers that are part of the condenser-type microphones. If a tube burns out, we know it.

"The announcement goes out over the public-address system that reaches every room in the studio, and wherever Mr. Luboviski goes, he is pursued by a loud speaker, so he cannot help knowing when it is his turn to play. Furthermore, when the announcer 'cuts over' to the studio after making his announcement, the remaining half of the lights in that room go on. Half of them are already burning, but the brightening of the room warns the artist that the microphone is 'alive,' preventing any slips."

He fingers one of the group of knobs in the north central part of the switchboard. "This is the microphone mixing panel, and these knobs do the mixing. Any or all of the six studios can be put on the air at the same time. Local programs can be broadcast simultaneously with field events, or as many as eight separate programs can be superimposed upon one another—if anybody wants to listen to them. They can be 'faded-in' to one another and mixed in any desired proportion.

**The "Monitoring"**

"The loud speaker you see is not operated from the same public-address system as the others. We are more exclusive in this department; our program comes, not from the common source, but from a super-heterodyne tuned to KNN's wave; so that we hear our own programs just as they sound outside. It is therefore unnecessary, when a cockroach gets into the microphone or a modulator has a fit of the collywobblers, for all the listeners within an airline radius of fifty miles to call us on the telephone and tell us about it. It sounds even worse here to us than it does to them. That is no joke, however, about the number of calls. Not long ago, when some one deliberately interfered with a certain speech broadcast through a local station, so many calls came in that the battery of the nearby Hollywood telephone exchange was run down!

"These two big knobs are the master gain controls, by means of which we keep the sound level within reasonable limits. The speech currents are mixed, amplified twice, and then sent through the 'equalizing pairs' over the telephone wires, amplified again in the telephone exchange, and yet again at the station before entering the modulator. The 'monitoring' is done here, and the needle of the meter is not allowed to swing past the red mark on either side of zero. All equipment is, of course, in duplicate, as an emergency measure. Accidents are rare; but here is something that in such emergencies does more than any other thing to save technicians from the padded cell."

He turned to the large speech amplifier panel and indicated a square switchboard section, set just beneath the long black

**CORWICO**  
**VULCAN**  
**LIGHTNING ARRESTER**



**Also Ejects Static Charges  
Improving Reception**

The Corwico Vulcan Lightning Arrester is manufactured in accordance with a new engineering principle that protects your radio against damage from lightning and also dissipates accumulated static charges. Buy one today for lightning protection and better reception.

AT YOUR DEALER'S OR DIRECT  
UPON RECEIPT OF PRICE

**CORNISH WIRE CO.**  
36 CHURCH ST., NEW YORK CITY

MAKERS OF THE FAMOUS



**BRAIDITE HOOK-UP WIRE**

**Aluminum Box Shields**

Beautiful silver dip finish, 5"x9"x6"—\$1.75. We make any size to order in 24 hours.

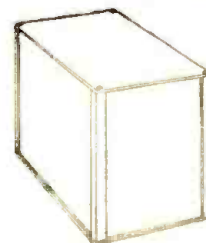

Muter miniature S.P.D.T. Switch 19c.  
Yaxley switches always in stock.  
All types of adapters.  
Full stock of Weston, Jewell and Readrite meters.  
Full stock of Amertran, Pilot and Octo-Coil forms and coil shields.  
Genuine Baldwin Type "C" phones, a necessity for short-wave reception, \$3.65 a pair.

Brach TEST-O-LITE fits your vest pocket, \$1.50—postage prepaid.  
Rider's Trouble Shooter's Manual—\$3.50.  
Rider's Treatise on Testing Units—\$1.00.

**BLAN THE RADIO MAN, Inc.**  
Est. 1923  
89D CORTLANDT ST. NEW YORK

★ ★ ★  
**TRI-STATE HEADQUARTERS**  
Pennsylvania—Ohio—West Va.  
**WHOLESALE RADIO**

To DEALERS and SET BUILDERS we offer the most prompt and efficient service. We handle only the best merchandise and give MAXIMUM DISCOUNTS.

★ **GET OUR CATALOG** ★

**CAMERADIO**  
430 WOOD ST.  
at Diamond St.  
**PITTSBURGH PA.**

When writing to advertisers, please mention RADIO-CRAFT.



## Ex Libris Beautiful Bookplates

DO YOU TAKE PRIDE IN YOUR LIBRARY?

A PERSONAL bookplate, with your name on it, insures you against loss of your cherished volumes. The friend who borrows your book can't fail to be reminded that it belongs to you!

A bit of the feeling of the great Old Masters is captured for you in our artistic Duo-Tone Bookplates, reproducing old woodcuts and engravings, on antique-tint vellum paper. \$2 up per hundred, your name imprinted. Send 10c for specimen and illustrated catalogue of our unique new series.

ISKOR PRESS, Inc.  
286 Fifth Ave. (Dept. 9) New York

# PATENTS

## Protect Your Ideas

Write for Instructions, free on request - - or send drawing or model for preliminary examination of Patent Office records

Promptness Assured with Best Results

### Carl Miller

PATENT ATTORNEY

Former Member Examiners Corps,  
U. S. Patent Office  
265 MCGILL Building, Washington, D. C.

## ATTENTION— RADIO SERVICE MEN

Leading manufacturers often consult us for the names of competent service men who are actively engaged in radio work.

We want every reader of RADIO-CRAFT who is engaged as a service man to read page 309 of this issue. You will find the few minutes reading this page well worth while.

boxes containing the relays. Over a hook hangs a bunch of short cords, terminated at both ends by plugs.

"Every circuit in the outfit here is brought out to these jacks. In a very short time we can go over the entire installation and localize the trouble down to the individual circuit, without removing a single panel or opening up the switchboard at all. It is not necessary to overhaul the entire station when something goes wrong; we can go right to the offending part and replace it in less time than it would take to shoot trouble in a one-tube blooper."

"Oh, yes," we said, understandingly. "So you operators have an easy life of it, after all." And we slipped through the door just in time to dodge the Type 216-B tube that came hurtling our way.

## A Resonance Tuner

(Continued from page 329)

may be produced by small impulses. This, I believe, may be properly called 'wave resonance'—that is, resonance resulting from a wave traveling on a conductor; the length of the conductor being properly adjusted in relation to the frequency or the wavelength of the oscillation."

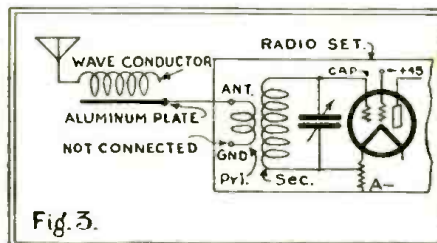

Fig. 3.

This is a recommended method of connecting a wave-resonance coil.

With this as an accepted definition of the new method of tuning, Dr. Cohen points out its possibilities—a high degree of selectivity, the elimination of interfering signals, and multiplex reception, as well as transmission, of radio signals.

After showing by mathematical calculation that open oscillators are capable of selective tuning, Dr. Cohen was confronted with the difficulty that a straight conductor, or piece of wire, would be of such great length as to make its use almost prohibitive and to render tuning too unwieldy. Hence, we find the development of a long conductor—400 turns of wire—compressed into a small coil. This is the practical method of using the wave-resonance principle for tuning. (These coils of wire, as well as the plates of aluminum, offer a wide latitude of construction with respect to sizes and shapes, all of which vary with wavelength requirements.) "The assumption that a conductor of this kind,"

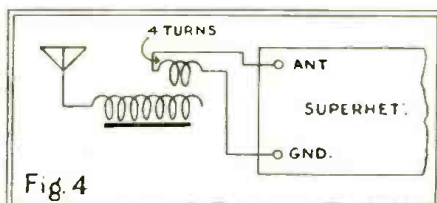

Fig. 4

Wave-resonance tuning applied to a superheterodyne. Even one turn may suffice as coupling.

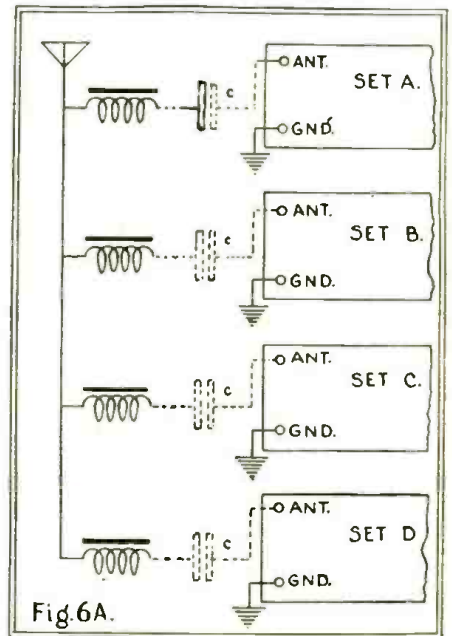

Fig. 6A.

Multiple reception. In this illustration the wave-resonance coils have been placed in non-inductive relation to the grid circuit inductances; the coupling which takes place is almost entirely by the coil-to-coil capacity afforded.

we are told by Dr. Cohen, "possesses the characteristics of uniformly distributed inductance and capacity may not be strictly true; but it is sufficiently accurate for the formulation of a working theory." Upon this assumption a practical structure has been erected and the results of practice checked against the forecasts of theory.

### Application of the Principle

Double tuning is effected by the wave-conductor—a small part of it tunes out the antenna's capacitive reactance, and on the remainder of the wave-conductor a quarter

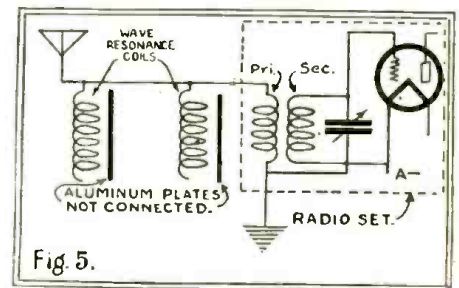

Fig. 5.

A wave-trap effect, obtained by use of the wave-resonance coil. This arrangement is quite unlike any other "wave-traps," in both theory and performance.

wave-length is established. This is accomplished by a single adjustment—a mere variation of the distance of the aluminum plate from the coil of wire. However, the tuning of the wave-conductor is a matter, not only of frequency, but also of the length of the antenna. Therefore, in employing this method of tuning, it is necessary to avoid that condition wherein the length of the antenna approximates a whole wavelength or a multiple of the wavelength. For instance, in tuning short-wave sets, if the length of the antenna is equal to the wavelength of the selected frequency, there is no voltage transfer to the wave-conductor; but a virtual zero condition instead.

The wave-conductors may be coupled to



# CHEMISTRY

If you are interested in chemistry, you will be pleased to hear that a magazine written in plain English, containing a vast amount of information for the beginner and the more advanced student in chemistry is being published now.

## Chemical Experimenter

is a Monthly Magazine chock-full of interesting Departments, edited by men who know how to state worthwhile facts.

There are departments about:

"Chemistry in the Home" — "History of Chemistry" — "Experiments in Chemistry" — "Biographies of Celebrated Chemists" — "Chemistry for the Beginner" — etc., etc.

Send the coupon below and you will receive all information about this Magazine.

CHEMICAL INSTITUTE OF NEW YORK, INC.,  
16 East 30th Street, New York, N. Y. RC-1  
Gentlemen:

Please send me free of charge all information about  
**CHEMICAL EXPERIMENTER**

Name .....

Address .....

Town .....

*Philadelphia*  
*Your Choice Should Be*  
The  
**HOTEL MAJESTIC**  
BROAD ST. AND GIRARD AVE.

400 Large Rooms

Only Hotel in Philadelphia with a subway entrance from main lobby

Most Moderate Rates!

Single Room, running water...\$2.00  
For Two...\$3.50  
Single Room, private bath...\$3.00  
For Two...\$5-\$6

Garage Connected with Hotel

Wire at our expense for reservations

JNO. C. GOSSLER, Mng.-Dir.

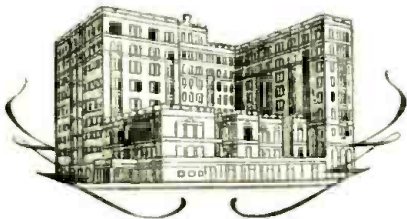

If you are a service man, professional or radiotrician you should receive RADIO-CRAFT each month. Turn to page 350 of this issue and read the special offer to those who are actively engaged in radio.

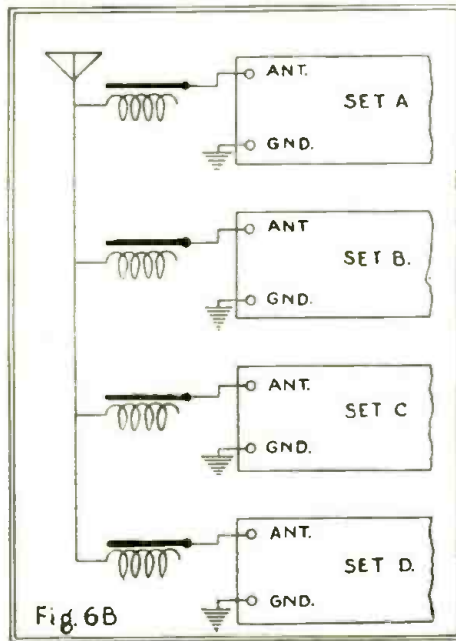

Fig. 6B  
Multiple reception. In this circuit the coupling takes place in a ratio somewhat different from that which obtains in Fig. 6A.

receiving sets in a variety of ways. The simplest procedure, however, is to couple a closed circuit, preferably tuned, to the wave-conductor; and the voltage developed across the condenser of the closed circuit is applied to the grid-filament of a detector (Fig. 1, C and R being the usual grid condenser and leak).

An extra and finer degree of tuning, however, is possible by use of the wave-conductor with tuned radio-frequency amplifiers. In this case, it is necessary only to place one of these devices close to a receiving set, as indicated in Fig. 2, connecting the aerial to the tuner, instead of the set's "Ant." post. Capacitative coupling results, as the dotted symbol indicates.

Another arrangement which is approved by the Signal Corps Laboratories is to connect the aluminum plate of the wave-conductor to a receiving set (Fig. 3). Thus, by proper spacing of the plate from the coil this metal plate plays a dual note—adjusting the wave-conductor and acting as coupler. In one instance, a high-grade commercial radio receiver, with an untuned primary, was employed with this new device. The aluminum plate of the wave-conductor was connected to one terminal of the primary coil and the other terminal remained open. The coupling from the primary to the tuned secondary circuit was capacitive; and the volume and selectivity of the signals thus obtained were entirely satisfactory. A superheterodyne was inductively coupled as shown in Fig. 4.

### Increasing Selectivity

Wave-resonance tuning is proposed as a means for eliminating interference due to an over-supply of transmitting stations. "It has been shown," points out Dr. Cohen, "that a wave-conductor connected in series with an antenna can be made to respond resonantly by proper adjustment to signals of a particular frequency, and it should follow that it functions efficiently as an energy absorber of an interfering signal of that particular frequency." The receiver is connected to the antenna in the usual manner

# Here's the Answer

to every question about the principles, methods, or apparatus of radio transmitting and receiving. A complete course in radio operation in a Single Volume

# The RADIO MANUAL

A New Edition

Complete new chapters on aircraft radio equipment; Practical Television and Radiomovies with instructions for building a complete outfit; radio interference; 100% modulation; latest equipment of the Western Electric Co.; the Marconi Auto-Alarm System; and many other developments of the past year. All this information is added to the new edition and, besides, the entire book has been brought right up to date with much new material. THE RADIO MANUAL continues to be the one complete and up-to-the-minute handbook covering the entire radio field.



A Handbook for  
Students  
Amateurs  
Operators  
Inspectors

Twenty big chapters cover:  
Elementary Electricity and Magnetism; Motors and Generators; Storage Batteries and Charging Circuits; The Vacuum Tube; Circuits Employed in Vacuum Tube Transmitters; Modulating Systems and 100% Modulation; Wave-meters; Piezo-electric Oscillators; Wave Traps;

Marine Vacuum Tube Transmitters; Radio Broadcasting Equipment; Arc Transmitters; Spark Transmitters; Commercial Radio Receivers; Marconi Auto-Alarm; Radio Beacons and Direction Finders; Aircraft Radio Equipment; Practical Television and Radiomovies; Eliminating Radio Interference; Radio Laws and Regulations; Handling and Abstracting Traffic.

An immense amount of information never before available, including detailed descriptions of standard equipment, is presented.

### Prepared by Official Examining Officer

The author, G. E. STERLING, is Radio Inspector and Examining Officer, Radio Division, U. S. Dept. of Commerce. The book has been edited in detail by ROBERT S. KRUSE, for five years Technical Editor of QST, the Magazine of the American Radio Relay League. Many other experts assisted them.

### Free Examination

The new edition of "The Radio Manual" has just been published. Nearly 900 pages, 369 illustrations. Bound in Flexible Fabrikoid. The coupon brings the volume for free examination. If you do not agree that it is the best Radio book you have seen, return it and owe nothing. If you keep it, send the price of \$6.00 within ten days.

### Order On This Coupon

D. VAN NOSTRAND CO., INC.,  
250 Fourth Ave., New York, N. Y.

Send me the Revised Edition of THE RADIO MANUAL for examination. Within ten days after receipt I will either return the volume or send you \$6.00, the price in full.

(Radio-Craft 1-30)

Name .....

St. and No. ....

City and State .....

# A Special Courtesy to all

Radiotricians  
Professionals  
Engineers  
Mechanics  
Consultants  
Designers  
Service Men  
Contractors  
Manufacturers  
Dealers

In order to make it possible for all Radio Technicians to read RADIO-CRAFT regularly, each month, we have put into effect a special subscription price.

The regular price of RADIO-CRAFT is \$2.50 per year (12 issues). The newsstand rate is 25 cents a copy.

Any radio professional, sending in a subscription on his letterhead, showing that he is engaged in some capacity in radio work will receive as a special courtesy

EIGHT ISSUES OF



FOR ONE DOLLAR

Just pin a dollar bill to the coupon below and forward it with your letterhead or business card.

RADIO-CRAFT,  
RC-1, 98 Park Place,  
New York, N. Y.

Enclosed find \$1.00 for which please enter my subscription to RADIO-CRAFT for eight months.

Name .....

Address .....

City..... State.....

and a wave-conductor is connected to the junction of the antenna and receiver, Fig. 5. By the proper adjustment of the wave-conductor to the frequency of any particular interfering signal, a voltage wave for that frequency is established at the junction point of antenna and receiver. Consequently, very little if any signal current of that particular frequency will pass through to the receiver.

Wave-resonance tuning lends itself to multiplex transmission as well as reception. In the latter, it is proposed that antenna congestion on apartment houses may be relieved by the use of one large pick-up system and a series of these new wave-conductors. From the large antenna, according to the proposal, lead-wires would extend to the various apartments; each connecting to a wave-conductor which would be coupled to a receiving set (Figs. 6A and 6B). There would be no appreciable decrease of signal strength except when all the receivers in any one apartment-house were tuned to one wavelength. The latter condition is not likely; except on a local radio broadcast station, when the received energy would be ample to accommodate all of the receivers operating at the same time. Already, Major Blair has applied wave-resonance tuning to multiplex transmission. Three transmitting sets are functioning simultaneously on different frequencies from one antenna, as shown in Fig. 7, in the next column. This can be done without occasioning interference.

## Radio-Craft Kinks

(Continued from page 328)

dedicated at T in Fig. 4, while the potentiometer contact C is moved from place to place by turning the knob on the potentiometer. Stop turning when the point is reached which gives the weakest click in the phones when the contact T is touched to the battery terminal. Now estimate the ratio of the length of wire in the potentiometer on side a, to that on side b. This ratio (a/b times the known resistance) gives the value of the unknown.

For example: You have a resistor which you think is 250 ohms. You have a resistor marked 500 ohms and a 500-ohm potentiometer. You find the proper position for c and estimate the ratio a/b to be 1/2.

R<sub>x</sub>, the unknown, is 1/2 R<sub>1</sub>, the known.

Then R<sub>x</sub> = 1/2 × 500 = 250 ohms. If a/b had been 1/1, R<sub>x</sub> would equal 1/1 × 500 = 500 ohms.

Be sure to make the connections just as they are shown in the figure. Most any battery will do; but do not use a "B" battery unless you are sure your resistors are each over 1000 ohms, to prevent excessive current drain and possible burnout of the headphones.

## The "Radiophon"

(Continued from page 330)

With a strong signal, amounting to about 3 volts (effective), there is a weak audible effect without any polarizing voltage. With strong A.C. voltages, the lower tones come out more and more clearly, finally shutting out the higher octaves, as the D.C. component is increased.

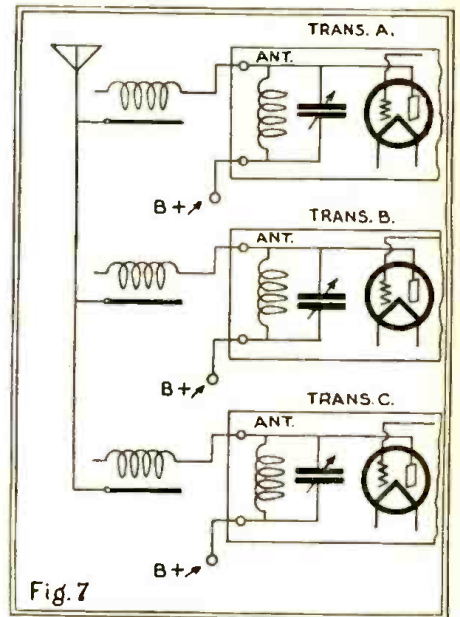

Fig. 7  
Multiple transmission through a single antenna is obtained by the use of wave-resonance coils for couplers. These pass only the frequencies to which they are tuned.

Short-circuiting the condenser C does not perceptibly change the effect. The use of the parallel resistor R<sub>2</sub> slightly weakens the reception, but is nevertheless desirable. The volume of sound is less than with magnetic phones; but the reproduction, especially of speech, is much more faithful.

The best material found for the diaphragm is "cellophan," a substance which is not af-

## POTENTIOMETER

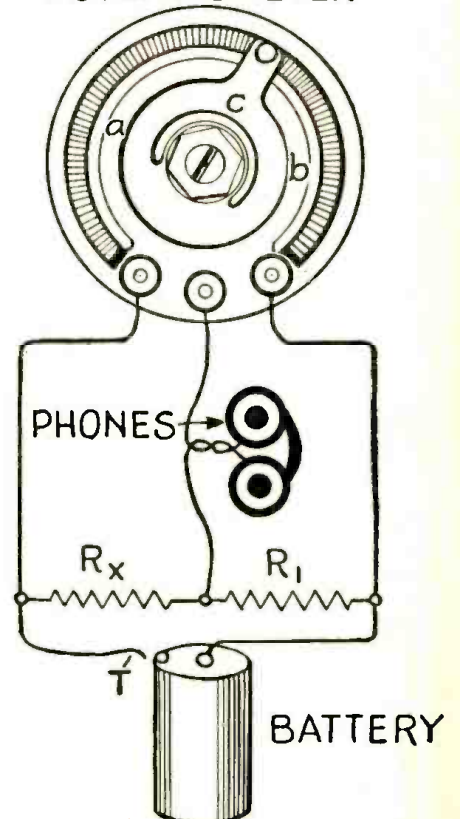
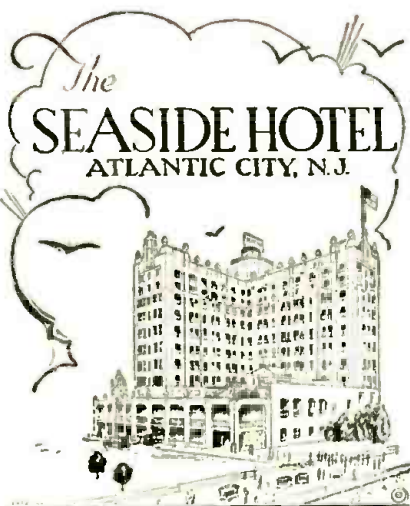

Fig. 4

This simple kink provides a bridge circuit whereby a resistor's approximate value may be determined, with a potentiometer whose resistance strip is evenly wound.



1873-1930

NEW in construction and furnishings—OLD in hospitable traditions.

Famous for its home-like atmosphere. The SEASIDE is a rare combination of a thoroughly modern hotel and a great private home with your friends about you.

AMERICAN PLAN

- Single rooms, running water, \$5 a day, \$30 a week up
- Double rooms, running water, \$10 a day, \$56 a week up
- Single rooms, private bath, \$7 a day, \$42 a week up
- Double rooms, private bath, \$14 a day, \$70 a week up

COOK'S SONS CORPORATION

# To New Readers

A few copies of the July, August, September, October, November and December issues of RADIO-CRAFT can still be had at the regular price of 25c each. Send cash, stamps or money order to

RADIO-CRAFT

98 Park Place

New York

fectured by moisture and is used exclusively in the late models. Genuine or artificial parchment is also very good. It is metallized on one side, by the iodol-spray process, or with gold-leaf which is attached by the use of albumen under heat and high pressure. Many other combinations of thin sheet metal and insulators are serviceable.

The formula for the force of attraction between the plates of the condenser (formed by the human body and the metallized diaphragm of the "Radiophon," and similar in action to the electrostatic reproducers which have been recently described in *Ramo-Cover*) shows that the higher the dielectric constant of the membrane, and the thinner it is, the greater the efficiency should be. So, also, the force varies as the square of the applied voltage, and consequently it would seem desirable to find by experiment the optimum D.C. potential for a given signal strength.

## Book Review

*Elements of Radio Communication.* By John H. Mowcroft; published by John Wiley and Sons, Inc., N. Y. C. (Chapman and Hall, Ltd., London); 6" x 9", 270 pages, 6 tables, 170 illustrations, red cloth cover. Price, \$3.00.

The author of this volume needs no introduction to the readers of RADIO-CRAFT. He is well-known as the author of the classic, *Principles of Radio Communication*, with which we compare and contrast *Elements of Radio Communication*.

The purpose of this book is clearly outlined in the preface: "There are thousands of students today, in school and out, who are sufficiently interested in the subject to desire something more sound and thorough than the many 'popular' texts on radio which have appeared, but who have neither the preparation nor time to attempt such a text as the author's *Principles*. It is for these students that the later volume has been prepared.

"This text is not a collection of excerpts from the larger volume, but has been written entirely anew. The general scheme is the same as that which gave the *Principles* its popularity, namely, a general review of those parts of the alternating-current theory which are of fundamental importance in radio, followed by the specific application of these principles to radio telegraphy and telephony.

"Practically no mathematical preparation, more advanced than algebra, is required for complete mastery of this elementary text. It is, nevertheless, sufficiently complete for any radio enthusiast except the engineers specializing in this branch of communication; for these the text forms a reasonable introduction to the subject."

A Practical Book

The *Elements* may be considered as a text exposition of the practical application of radio theory. The derivations of each fundamental equation are clearly given as well as the equation; as well as specific examples of their use.

As each new point in terminology is reached, the word is emphasized either in boldface type or by the use of quotation marks. This is an aid to the ready comprehension of their meaning.

Another desirable arrangement of the book includes a set of 117 "problems"; they are divided into sections, each being related to a chapter in the volume. The reader must furnish the answers.

Considerable space has been devoted to the problems of broadcast-station design and operation. There are 156 pages in the chapter, "The Vacuum Tube and its Uses"; the now-popular screen-grid tube being well represented.

It is necessary in a book of this size and style to take a certain amount for granted; nevertheless the technical accuracy has been held to a high level.

It is impossible in the space here available to picture properly the wide scope of this volume, other than to state that there are sub-headings which refer to 168 different subjects.

To sum up, *Elements of Radio Communication* is an excellent text book, and very "easy" to read. Technical accuracy has been maintained on a wide variety of subjects; and it contains in convenient form the answers to the less abstruse problems of every-day radio engineering. (R. D. W.)

FOR SALE

LEUTZ TRANSOCEANIC "PHANTOM"

NINE TUBES — 100% SHIELDING — INTER-CHANGEABLE R.F. TRANSFORMERS

This is one of the finest de luxe sets that has ever been put out. It is brand new and has never been used. It is sold at a big sacrifice. The first order takes it. The "Phantom" has been used on the U. S. S. Vega and U. S. S. Utah. Licensed under Patent No. 1,041,002.

Aluminum cabinet — length, 27 in.; depth, 8 in.; width, 13 1/2 in.; weight, 33 lbs.

Has twelve controls on front panel. Five thumb control tuning dials; four of them ganged together and the other separately, leaving really only two of them for tuning stations; although individual stage tuning may be had if desired.

Two rheostats: One controls the four radio frequency stages, the other controls the detector. Three resonators: One for the second radio frequency stage, one for the fourth radio frequency stage and one for the detector stage.

One volume control. Filament switch. An eight point meter switch which gives you "A" battery, "B" battery and "C" battery reading by moving the switch one to eight. No. 1 on switch gives you filament voltage on detector; No. 2 on switch gives you filament voltage on R.F. tubes; No. 3 on switch gives you "A" bias on detector; No. 4 on switch gives you "B" bias on R.F. tubes; No. 5 on switch gives you "B" voltage on detector; No. 6 on switch gives you "B" voltage on R.F. tubes; No. 7 on switch gives you "B" voltage on audio frequency tubes; No. 8 on switch gives you "B" voltage power for use with a 210 tube only.

Notes: Two scale meter 0 to 7; other 0 to 150.

In using No. 8 in switch you multiply the upper scale reading by 5 which brings the scale reading up to 750 volts. The set has four stages of tuned radio frequency, a detector, and four stages of audio frequency. There are twenty binding posts in the back of set for "A," "B," "C" batteries, loop, antenna and speaker. Tubes recommended: Seven "01 A's, one 200-A, one "10.

LIST PRICE \$250.00

I will sell this set to the first comer for \$50.00; transportation to be paid by purchaser. This set is now on the premises of RADIO-CRAFT, which alone should be sufficient evidence that the above statements are true.

JAMES W. SULLIVAN

c/o RADIO-CRAFT

98-98 Park Place New York City

## Orders - Inquiries



### POLK'S REFERENCE BOOK and Mailing List Catalog

Gives counts and prices on over 8,000 different lines of business. No matter what your business, in this book you will find the number of your prospective customers listed. Valuable information showing how to use the mails to secure orders and inquiries for your products or services is given.

Write for FREE Copy

R. L. POLK & CO., Detroit, Mich. Largest City Directory Publishers in the World. Branches in Principal Cities Mailing List Compilers—Business Statistics Producers of Direct Mail Advertising

## Choice of 1200 Newest RADIO VALUES

SEND for our wholesale 1930 S catalog. Filled with amazing values in screen grid radios, 245 PUSB full audio, radio, consoles, kits, parts. Guaranteed merchandise at wholesale prices. **FREE**

WESTERN RADIO MFG. CO. 124 W. LAKE ST. CHICAGO ILL.

# Become a Trained Radio-Technician

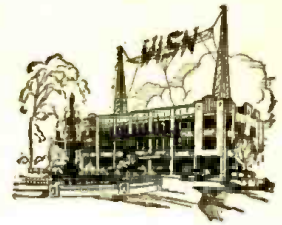

Towers of Broadcasting Station WISN on School of Engineering building. This station now being operated by School of Engineering.

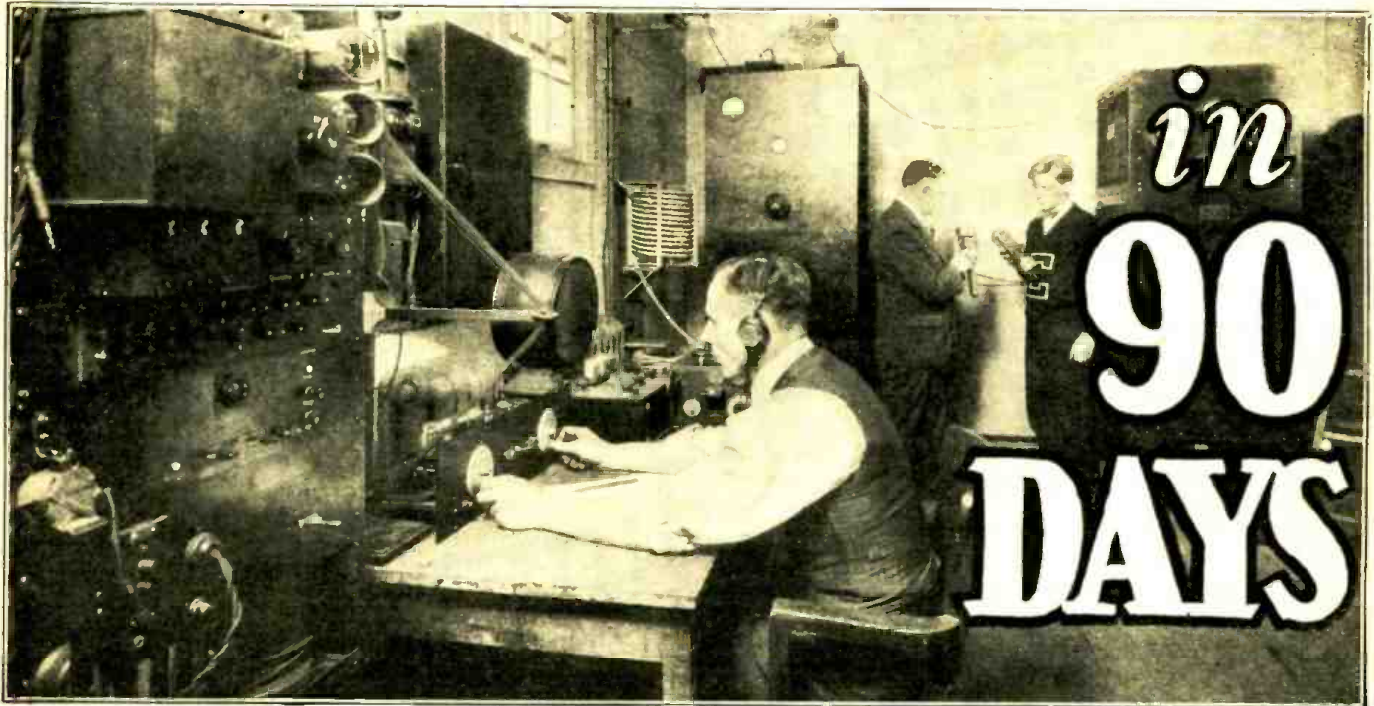

## RADIO INDUSTRY PLEADS For "Registered" Radio Experts

Opportunity beckons as never before in the Radio Industry. Good paying positions, interesting work, a chance to become independent—radio offers all this and more to ambitious men who seize the opportunity NOW!

The Wisconsin Radio Trades Ass'n now compels every radio service man to pass severe examinations and become registered. Dealers are tired of untrained, incompetent help. Radio trade associations the country over are planning to follow Wisconsin's example. The School of Engineering is the only institution in the country whose course is approved by a radio trade association. Graduates of the S. of E. are "registered." 14 S. of E. men successfully employed by Radio Corp. of American Photophone, Inc.

### Most Thorough, Practical Radio Course in America

Here in this big splendidly equipped electrical school (from which station WISN is operated) you can secure the most thorough, the most compact, practical radio training offered anywhere. Covers entire field of radio! Course includes Radio Laboratory Practice, Radio Telephone Theory, Radio Transmis-

sion, Code Instruction, Electrical Mathematics, Service and Installation, Radio Sales and Merchandising. Daily Broadcasting from WISN. All training is 100% practical. You secure a wonderful training in three short months!



Read this letter from Michael Ert, Pres. Michael Ert, Inc., Past Pres. of Wis. Radio Trade Ass'n, and now Pres. of the Federated Radio Trade Ass'n:

"We have investigated your Radio and Broadcast Course now being given at the School of Engineering of Milwaukee, and are acquainted with the high quality of educational work you have been doing for years.

Therefore, the Wisconsin Radio Trades Association hereby authorizes you to prepare men to receive Radio Serviceman's Registration Cards, classes A, B or C, of the Wisconsin Radio Trades Association."

### Television Included

Complete radio course also includes study of the fundamentals of Television, which is still in the experimental stage, but will soon offer a wide field of usefulness to those who start to prepare now.

### Part-Time Job While You Learn

Not only do we help place our men after graduation, but we can arrange for part-time employment for ambitious men who can finance their tuition. This will cover part if not all of your living expenses while you are taking the radio course at the School of Engineering.

**FREE BOOK** Mail coupon today for copy of catalog describing the S. of E. 90 days' Radio Course and our Earn-While-You-Learn plan. Write now! Classes Now Organizing.

School of Engineering of Milwaukee, Dept. RC-130, Milwaukee, Wis.

Without obligation, please send me FREE Book describing your 3 months "Radiotrician" course and full details of your "Earn While You Learn Plan."

Name..... Age.....

Address .....

City..... State.....

**SCHOOL of ENGINEERING**  
of Milwaukee  
Founded 1903 Dept. RC-130 Milwaukee, Wis.

# WHAT EVERY ELECTRICIAN WANTS TO KNOW!

**JUST OUT!**—Latest Exact Information from A to Z!

We take pleasure in announcing: "AUDELS NEW ELECTRIC LIBRARY"

New and More Uses for Electricity offer great opportunities to men who can handle this power correctly. Modern electrification of industry calls for trained men who know how to handle electricity accurately.

Simple as A. B. C.—"Audels New Electric Library" gives latest, exact information from foundations of electrical practice to latest modern applications. This is a NEW practical and theoretical course in electricity for home study and ready reference.

Here are the answers to your questions, giving you the real dope that every electrician must know. They chart your knowledge, taking away the uncertainty of guess work.

**NEW!**

As Easy As ABC



Latest information, fully illustrated, covering:—

Fundamental Principles and Rules of Electricity, Magnetism, Armature Winding, Repairs, Dynamos, D.C. Motors, Construction, Installation, Maintenance and Trouble Shooting, Tests and Testing Instruments, Storage Battery, Construction and Repairs, Alternating Current Principles and Diagrams, Power Factor, Alternators, Transformers, A.C. Motors, Windings, Reconnecting, Converters, Switches & Fuses, Circuit Breakers, Relays, Condensers, Regulators, Rectifiers, Meters, Switchboards, Power Station Practice, House Light & Power Wiring, Circuits, High Tension, Transmission, Plans, Calculations, Code, Electric Railways, Signals, Elevators, Hoists & Cranes, Gas Engines, Auto & Aero Ignition, Starters, Radio, Telephone, Telegraph, Bells & Signals, Motion Pictures, Talkies, Lighting, Illumination, Electric Refrigeration, Heating, X-Ray, Plating, Welding, Pumps, Compressors, Domestic & Farm Appliances, An Electric Calculator for Engineers and Mechanics, Practical Mathematics for Ready Reference, A New Electric Dictionary & Encyclopedia of Words.

**7 Books**  
Now on Sale  
**5 in Preparation**

The Library contains 12 books—the first 7 books containing 3600 pages with thousands of diagrams and illustrations are now ready; the remaining 5 books are in preparation. A pocket-size, flexibly bound series that is valuable wherever electricity is used.

Beautiful, timely books for service—pocket size; completely illustrated with diagrams and charts; simplified, easy to read and understand. No electrical man can afford to pass up this opportunity. Extremely low price; buy on your own terms.

QUESTIONS AND ANSWERS  
**AUDELS NEW ELECTRIC LIBRARY**  
ILLUSTRATED

**NEW!**

SATISFACTION GUARANTEED!  
"Audels New Electric Library" is backed by our 50-year record as helping hand publishers. Satisfaction always guaranteed.

Beautiful, Timely Books



Read for Profit

**BUY ON YOUR OWN TERMS**

- PLAN 1—ONE BOOK A MONTH**  
Please enter my subscription to "Audels New Electric Library" to consist of twelve volumes, price \$1.50 a volume (\$10.50 for the seven volumes now ready). Mail one volume each month and as they are received, I will mail you \$1.50 promptly.
- PLAN 2—PAY 50c OR MORE A WEEK**  
Please ship me for one week's free trial the first seven volumes of "Audels New Electric Library." \$1.50 each (\$10.50 for the seven volumes now ready). The remaining five volumes to be mailed as issued at \$1.50 a volume. If satisfied, I will mail you 50c or more each week as payment for the first seven books and I will pay for the last five numbers as I receive them at \$1.50 each.
- PLAN 3—CASH PRICE \$9.98**  
Please ship me postpaid "Audels New Electric Library" for which I enclose remittance \$9.98 in full payment for the seven volumes now ready. You are to ship me on one week's trial the remaining five volumes as they are issued for which I will either pay \$1.50 each as received or return to you. This price is based on 5% cash discount.

THEO. AUDEL & CO.,  
65 West 23rd St., New York, N. Y.

Please ship me the NEW "Audels Electric Library" on the plan marked (X).

NAME .....

ADDRESS .....

OCCUPATION .....

EMPLOYED BY .....

Ger

# \$34.50

## SCREEN GRID TUBES

# SCREEN GRID CHASSIS

POWERFUL super-sensitive A. C. receiver establishing a new standard of perfection in radio design. Incorporating such advanced features as screen grid R. F., power detector, "245" push-pull power audio, dynamic tone quality plus practical scientifically shielded construction. Its super power assures unusual distance range—its ultra-selectivity adapts it for use in the most congested broadcasting-districts. Available in a wide range of beautiful consoles—dynamic speaker equipped.

**Write Today** for this new 196-page catalog full of all the latest in radio showing the new, humless, Screen Grid A. C. all-electric and battery operated sets. Beautiful consoles, dynamic speakers, accessories, parts, kits; everything in radio and all at rock-bottom wholesale prices. Hundreds of real radio bargains from a Radio House backed by over \$3,000,000 in resources. Send for it now before you buy anything more in radio supplies! **USE THE COUPON.**



# FREE RADIO CATALOG!

**ALLIED RADIO CORPORATION**  
711 W. Lake St. Dept. I-7 Chicago, Ill.

Allied Radio Corporation,  
Dept. I-7  
711 W. Lake Street, Chicago, Ill.

Please send me your new 1930—196-page radio catalog — which we understand is to be absolutely free.

Name.....  
Address.....  
City..... State.....